



SERVICE PARTS LIST

BULLETIN NO.
54-06-0164

SPECIFY CATALOG NO. AND SERIAL NO. WHEN ORDERING PARTS		REVISED BULLETIN	DATE
1/2" MAGNUM HOLE-SHOOTER		54-06-0163	Apr. 2010
CATALOG NO. 0234-6	STARTING SERIAL NO. 532D	WIRING INSTRUCTION	
		58-01-1651	

EXAMPLE:
Component Parts (Small #) Are Included
When Ordering The Assembly (Large #).

★ = Part number change
from previous service
parts list.

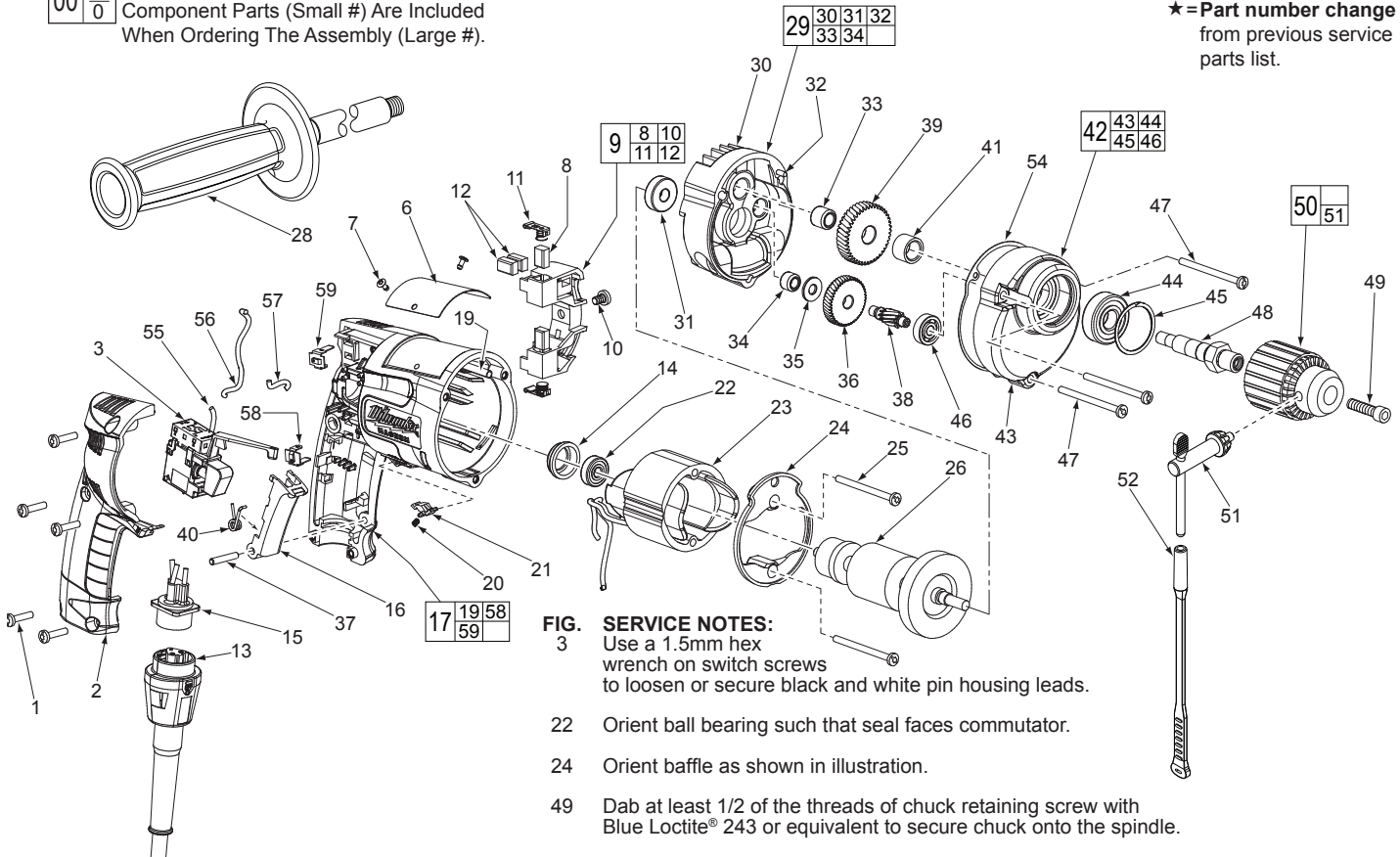

FIG. 3 SERVICE NOTES:
Use a 1.5mm hex wrench on switch screws to loosen or secure black and white pin housing leads.

- 22 Orient ball bearing such that seal faces commutator.
- 24 Orient baffle as shown in illustration.
- 49 Dab at least 1/2 of the threads of chuck retaining screw with Blue Loctite® 243 or equivalent to secure chuck onto the spindle.

FIG.	PART NO.	DESCRIPTION OF PART	NO. REQ.	FIG.	PART NO.	DESCRIPTION OF PART	NO. REQ.
1	06-82-7266	7-1/8 x 11/16" Pan Hd. Plastite T-20	(5)	38	36-66-4261	Intermediate Pinion	(1)
★ 2	31-15-0405	Handle Cover	(1)	39	32-75-2911	Spindle Gear	(1)
★ 3	23-66-1705	Trigger Speed Control Reversing Switch	(1)	★ 40	40-50-0525	Torsion Spring	(1)
★ 6	12-99-0077	Nameplate Blank	(1)	41	45-36-1100	Spacer	(1)
7	06-72-1720	Nameplate Rivet	(2)	42	14-30-0337	Gearcase Assembly	(1)
★ 8	22-16-0295	Carbon Brush	(2)	43	-----	Gearcase	(1)
★ 9	22-22-0352	Brush Holder Assembly	(1)	44	02-04-1229	Ball Bearing	(1)
★ 10	23-44-0200	Brush Holder Screw	(1)	45	34-80-2300	Retaining Ring	(1)
11	22-20-0345	Brush Spring Assembly	(2)	46	02-04-0640	Ball Bearing	(1)
★ 12	22-16-0295	Carbon Brush (Spares)	(2)	47	06-82-7411	7-18 x 2-3/16" Pan Hd. Plast. T-20	(3)
13	48-76-4008	Quik-Lok Cord Set	(1)	48	38-50-5251	Spindle - Double Reduction	(1)
14	22-72-0100	Bearing Cup	(1)	49	06-75-3150	1/4-20 x 1" Skt. Hd. Screw-L.H.Thd.	(1)
★ 15	22-56-0845	Pin Housing Assembly	(1)	50	48-66-1360	1/2" Chuck	(1)
★ 16	45-72-0085	Trigger	(1)	51	48-66-3280	Chuck Key	(1)
★ 17	14-38-0541	Motor Housing Assembly	(1)	52	48-66-4040	Key Holder	(1)
19	44-60-1290	Grounding Pin	(1)	54	43-44-0913	Gasket	(1)
20	40-50-0085	Lock Button Spring	(1)	★ 55	23-94-6248	Leadwire Assembly, Blue	(1)
21	42-42-0460	Lock Button	(1)	★ 56	23-94-6336	Leadwire Assembly, Black	(1)
22	02-04-0645	Ball Bearing	(1)	★ 57	23-94-6405	Leadwire Assembly, White	(1)
★ 23	18-11-0076	120 Volt Field	(1)	★ 58	23-74-1030	Terminal, Lower	(1)
★ 24	42-14-0393	Baffle	(1)	★ 59	23-74-1040	Terminal, Upper	(1)
25	06-82-7398	7-18 x 2-1/16" Pan Hd. Plast. T-20	(2)	★	10-98-5996	Warning Label (Not Shown)	(1)
★ 26	16-10-0801	120 V. Armature Assembly	(1)				
★ 28	43-62-0886	Side Handle Assembly	(1)				
★ 29	14-13-0499	Diaphragm Assembly	(1)				
30	-----	Diaphragm	(1)				
★ 31	02-04-0851	Ball Bearing	(1)				
32	06-65-0880	1/8 x 1/2 Groove Pin No. 5	(1)				
33	02-50-2435	Needle Bearing	(1)				
34	02-50-1620	Needle Bearing	(1)				
35	45-88-7721	Heat Treated Washer	(1)				
36	32-40-1816	Intermediate Gear	(1)				
★ 37	06-65-0105	4 x 22 Pin	(1)				

FIG. LUBRICATION (Type 'E' Grease, No. 49-08-4122):

26,36, 38,39 Apply grease to all teeth of armature pinion, spindle gear, intermediate gear and intermediate pinion.

42 Place 42.6gm ±.5gm (approx. 1-1/2 oz) grease in gearcase cavity near ball bearing #46.

MILWAUKEE ELECTRIC TOOL CORPORATION
13135 W. LISBON RD., BROOKFIELD, WI 53005
Drwg. 4