



# SERVICE PARTS LIST

**BULLETIN NO.**  
**54-12-1306**

SPECIFY CATALOG NO. AND SERIAL NO. WHEN ORDERING PARTS		REVISED BULLETIN	DATE
<b>SUPER HOLE-SHOOTER</b>		54-12-1305	Aug. 2011
CATALOG NO. <b>1854-1</b>	SERIAL NUMBER <b>567C or 567D</b>	WIRING INSTRUCTION <b>58-01-0941</b>	

**EXAMPLE:**  
Component Parts (Small #)  
Are Included When Ordering  
The Assembly (Large #).

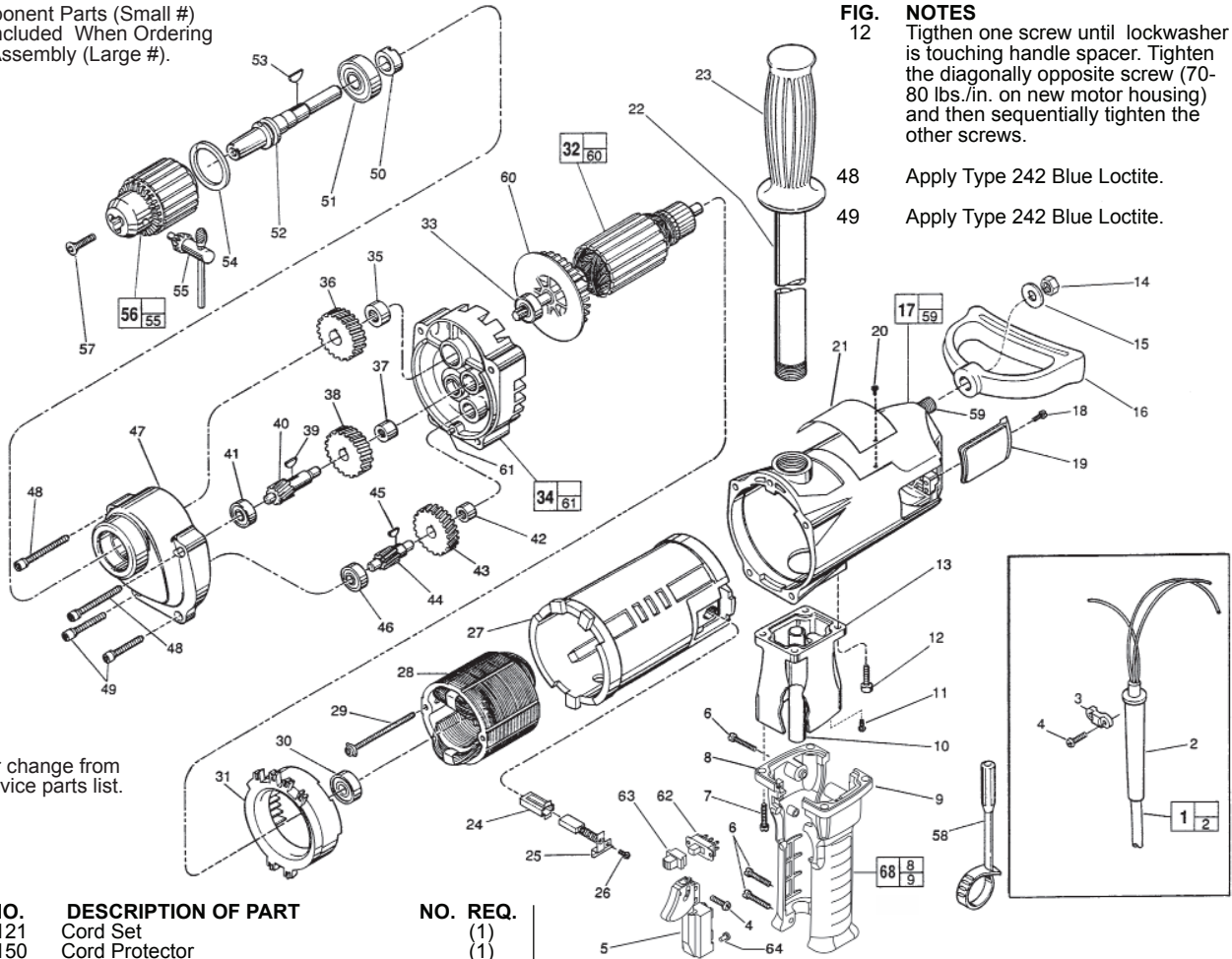

**FIG. 12 NOTES**  
Tighten one screw until lockwasher is touching handle spacer. Tighten the diagonally opposite screw (70-80 lbs./in. on new motor housing) and then sequentially tighten the other screws.

**48** Apply Type 242 Blue Loctite.  
**49** Apply Type 242 Blue Loctite.

\* = Part number change from previous service parts list.

FIG.	PART NO.	DESCRIPTION OF PART	NO.	REQ.
	1	22-64-0121	Cord Set	(1)
	2	44-76-0150	Cord Protector	(1)
★	3	31-17-0155	Cord Clamp	(1)
★	4	06-82-7270	8-16 x 5/8" Slotted Plastite T-20 Screw	(3)
★	5	23-66-0169	On-Off Switch	(1)
★	6	06-82-7326	8-16 x 1" Slotted Plastite T-20 Screw	(4)
★	7	06-82-5382	1/4-20 x 3/4" Pan Hd. Taptite T-27 Screw	(4)
★	8	-----	Right Handle Half	(1)
★	9	-----	Left Handle Half	(1)
10	23-16-1440	Insulating Tube	(1)	
11	06-95-5200	8-32 x 5/16" Slotted Hex Hd. Screw	(1)	
12	06-95-5645	1/4-20 x 3/4" Pan Hd. Taptite Screw	(4)	
13	25-86-1615	Handle Spacer	(1)	
14	06-55-2850	1/2-13 Hex Nut	(1)	
15	45-88-5253	Thrust Washer	(1)	
16	31-44-1450	Spade Handle	(1)	
17	28-50-6365	Motor Housing	(1)	
18	06-82-5316	8-32 x 1/2" Slit. Pan Hd. Taptite T-20 Screw	(2)	
19	22-32-0350	Brush Cover	(2)	
20	06-72-1720	Nameplate Rivet	(2)	
21	12-15-7510	Service Nameplate	(1)	
22	43-62-0121	Pipe Handle	(1)	
23	43-62-0246	Handle Grip	(1)	
24	22-20-0680	Brush Tube	(1)	
25	22-18-0701	Carbon Brush Assembly	(2)	
26	06-82-8835	8-32 x 5/16" Pan Hd. T-20 Sems	(2)	
27	23-16-1420	Insulated Housing	(1)	
28	18-70-0310	120 V. Field	(1)	
29	06-82-9072	10-24 x 2-1/8" Pan Hd. T-25 Sems	(2)	
30	02-04-1041	Ball Bearing	(1)	
31	42-14-0291	Baffle	(1)	
32	16-70-0340	120 V. Armature	(1)	
33	02-04-1229	Ball Bearing	(1)	
34	14-13-0241	Diaphragm Assembly	(1)	
35	02-50-4040	Needle Bearing	(1)	
36	32-75-1001	Spindle Gear	(1)	
37	02-50-2450	Needle Bearing	(1)	
38	32-44-1181	Intermediate Gear	(1)	
39	06-42-1600	Woodruff Key	(1)	
40	36-66-0501	Intermediate Pinion Shaft	(1)	

FIG.	PART NO.	DESCRIPTION OF PART	NO.	REQ.
41	02-04-0910	Ball Bearing	(1)	
42	02-50-2450	Needle Bearing	(1)	
43	32-40-1001	Intermediate Gear	(1)	
44	36-66-2601	Intermediate Pinion Shaft	(1)	
45	06-42-1200	Woodruff Key	(1)	
46	02-04-0910	Ball Bearing	(1)	
47	28-14-0402	Gear Case	(1)	
48	06-82-8440	1/4-20 x 2-1/2" Fil. Taptite T-30 Sems	(2)	
49	06-82-8396	1/4-20 x 2-1/4" Fil. Taptite T-30 Sems	(2)	
50	45-36-0200	Spacer	(1)	
51	02-04-2031	Ball Bearing	(1)	
52	38-50-5500	Reversing Spindle	(1)	
53	06-42-2400	Woodruff Key	(1)	
54	34-80-3450	Retaining Ring	(1)	
55	48-66-3160	Chuck Key	(1)	
56	48-66-2085	Chuck	(1)	
57	06-81-3100	5/16-18 x 1" Socket Hd. Screw	(1)	
58	48-66-4020	Chuck Key Holder	(1)	
59	06-14-0010	1/2 x 13 x 1-3/8" Hex Hd. Bolt	(1)	
60	22-84-0790	Fan	(1)	
61	06-65-1155	Pin	(1)	
★ 62	23-66-2517	Fwd./Rev. Switch	(1)	
★ 63	45-24-1005	Fwd./Rev. Shuttle Button	(1)	
★ 64	05-78-0305	Switch Screw	(4)	
★ 66	22-56-0150	Wire Connector (See Bulletin 58-01-0941)	(4)	
★ 67	23-94-8050	Jumper Wire (See Bulletin 58-01-0941)	(1)	
★ 68	31-44-1495	Handle Set	(1)	

**FIG. 47 LUBRICATION**  
7-3/4 Oz. "E" Grease, No .49-08-4122.

**MILWAUKEE ELECTRIC TOOL CORPORATION**  
13135 W. LISBON RD., BROOKFIELD, WI 53005  
Drwg. 2