



# SERVICE PARTS LIST

BULLETIN NO.  
54-06-2490

SPECIFY CATALOG NO. AND SERIAL NO. WHEN ORDERING PARTS		REVISED BULLETIN	DATE
<b>Cordless M12™ 3/8" Driver-Drill</b>			Feb. 2014
CATALOG NO.	2407-20	STARTING SERIAL NO.	F10A
		WIRING INSTRUCTION <b>SEE REVERSE SIDE</b>	

**EXAMPLE:**  
00 0 Component Parts (Small #)  
Are Included When Ordering  
The Assembly (Large #).

**\***  
Original Design  
42-70-0055

42-70-0058  
Improved Design

M12™ tools utilize two different Housing Connection Clip designs depending on the Handle Set. See page two for details.

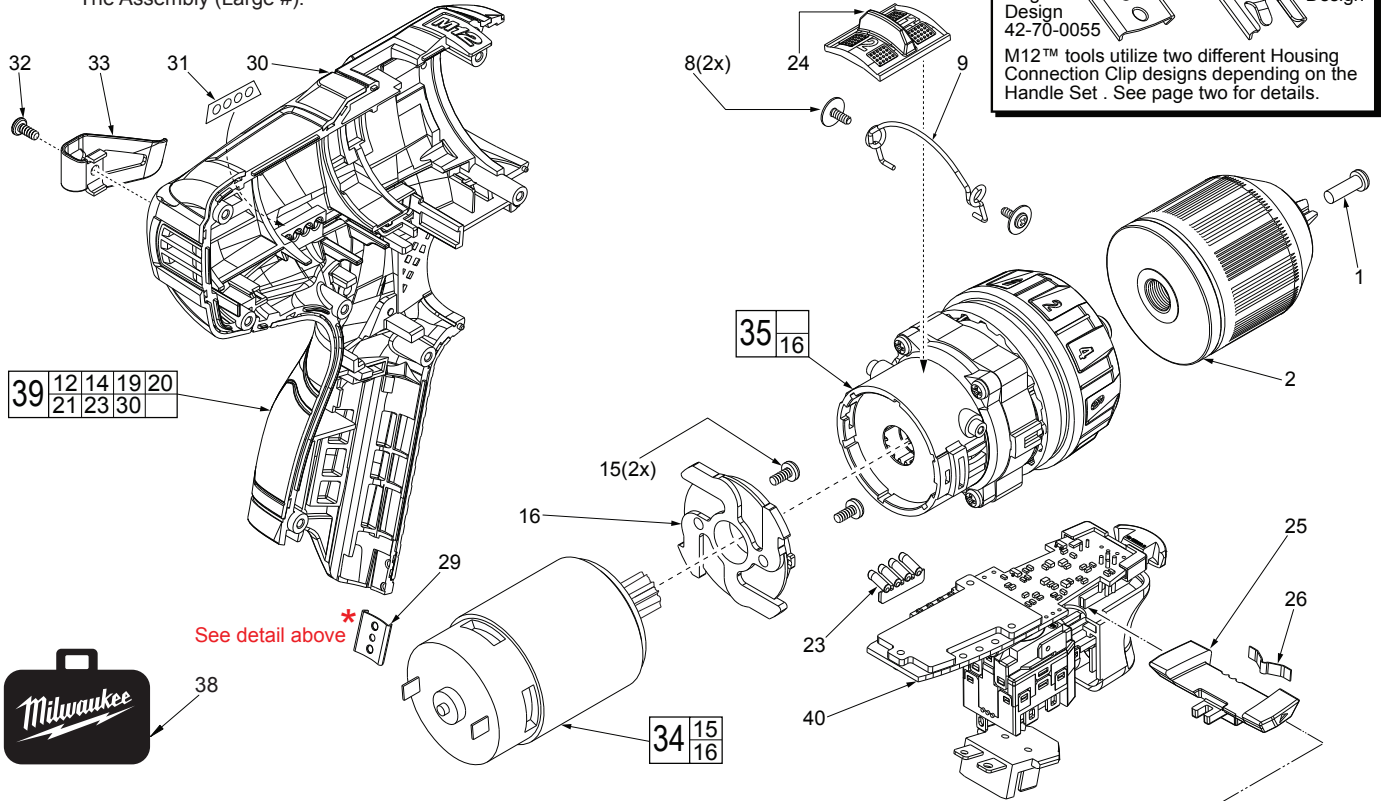

FIG.	PART NO.	DESCRIPTION OF PART	NO. REQ.
1	05-88-1680	M5 x 0.8 x 18.5mm LH Chuck Screw	(1)
2	42-66-0825	3/8" Keyless Chuck	(1)
8	05-81-0542	M2.3 x 4.5mm ST Screw	(2)
9	44-10-0710	Speed Selector Lever	(1)
12	06-82-1080	M3.0 x 14mm Pan Hd. T-10 ST Screw	(7)
14	-----	Housing Cover (Right Handle Halve)	(1)
15	-----	M3 x 6mm Screw	(2)
16	44-66-1585	Motor Mount Plate	(1)
19	12-20-2407	Service Nameplate	(1)
20	10-20-2810	Warning Label (Not Shown)	(1)
23	31-01-0003	Light Pipe	(1)
24	45-24-0325	Speed Selector Slide Button	(1)
25	42-42-0820	Forward/Reverse Shuttle	(1)
26	40-50-1135	Shuttle Spring Plate	(1)
29	42-70-0055	Housing Connection Clip	(1)
30	-----	Housing Support (Left Handle Halve)	(1)
31	-----	Fuel Gauge Label	(1)
32	05-88-1010	M2.5 x 6mm Pan Hd. Phillips Screw	(1)
33	42-70-0580	Belt Clip	(1)
34	14-50-2430	Service Motor Assembly with Pinion	(1)
35	14-29-0825	Service Gearcase Assembly	(1)
38	42-55-2105	Carrying Case	(1)
39	14-38-0250	Service Housing Set	(1)
40	23-66-1795	Service Switch/Electronics Assembly	(1)

**FIG. NOTES:**  
16,34,35 Service replacement gearcase assembly (35) comes with a motor mount plate (16) that must be removed and discarded when servicing. A motor mount plate already exists on the motor assembly (34).

