



# SERVICE PARTS LIST

BULLETIN NO.  
54-26-2420

SPECIFY CATALOG NO. AND SERIAL NO. WHEN ORDERING PARTS		REVISED BULLETIN	DATE
<b>M12 3/8" SQUARE ANVIL IMPACT WRENCH</b>			June 2013
CATALOG NO. <b>2463-20</b>	STARTING SERIAL NO. <b>F06A</b>	WIRING INSTRUCTION <b>SEE PAGE 2</b>	

**EXAMPLE:**  
00 0 Component Parts (Small #) Are Included  
When Ordering The Assembly (Large #).

FIG.	PART NO.	DESCRIPTION OF PART	NO. REQ.
5	14-30-0140	Gearcase Assembly with Bushing	(1)
8	45-88-2135	Nylon Ring	(1)
10	-----	3/8" Square Anvil	(1)
11	02-02-1300	5.0mm Steel Ball	(1)
12	-----	Hammer	(1)
13	-----	3.0mm Steel Ball	(27)
14	-----	Washer	(1)
15	-----	Compression Spring	(1)
16	-----	Retaining Ring	(1)
17	-----	Washer	(1)
18	-----	Washer	(1)
19	-----	Ball Bearing	(1)
20	-----	Gear Housing	(1)
21	-----	4.7mm Steel Ball	(1)
22	-----	Cam Shaft	(1)
23	-----	2nd Stage Planet Gear	(4)
24	-----	2nd Stage Ring Gear	(1)
25	-----	2nd Stage Sun Gear and Carriage	(1)
26	-----	1st Stage Planet Gear	(4)
27	-----	1st Stage Ring Gear	(1)
28	-----	Washer	(1)

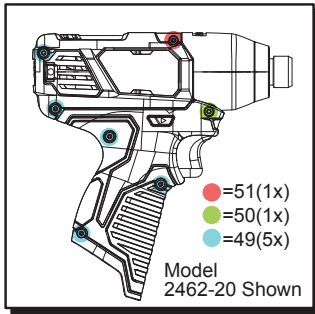
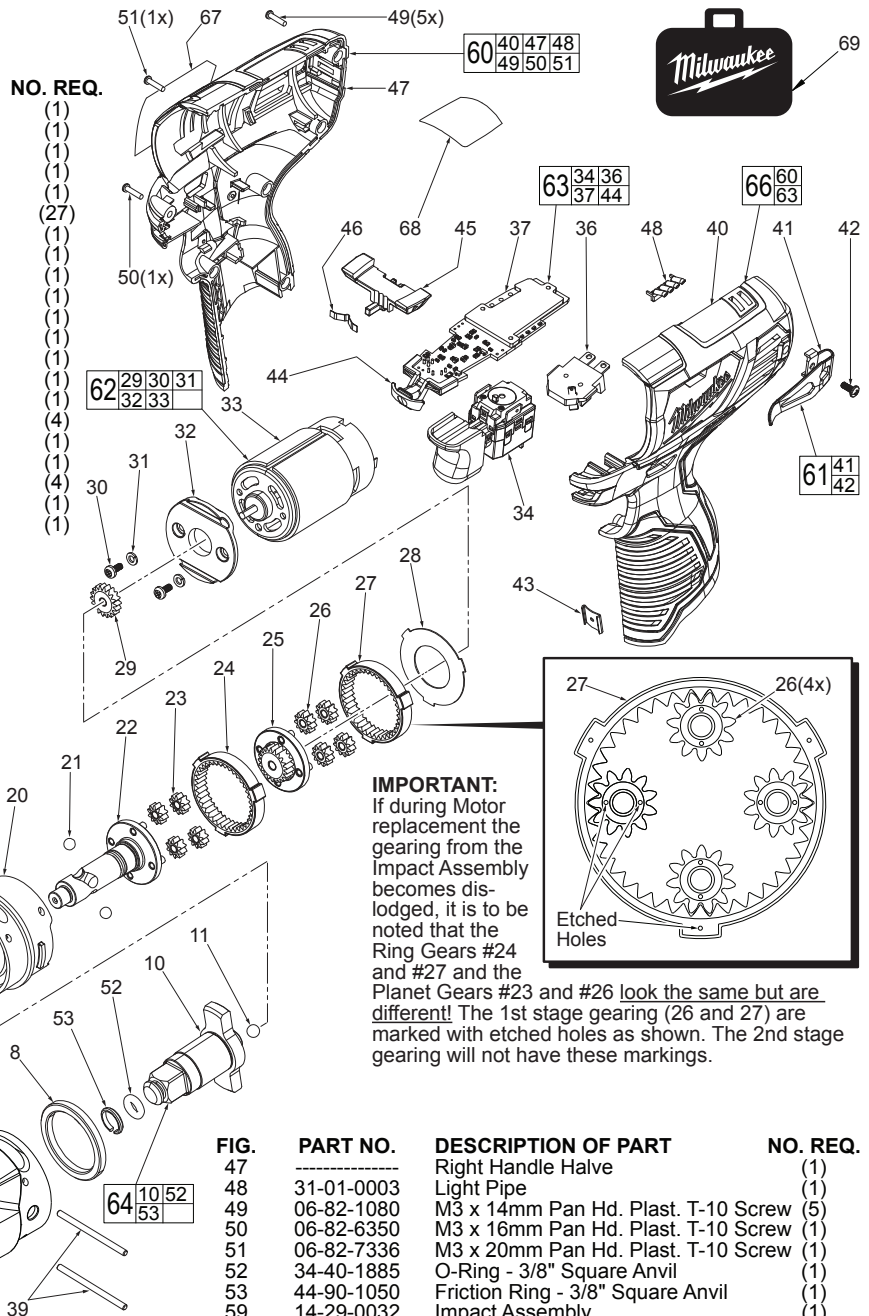

59	12	13	14	15	16	17	18	19	20
21	22	23	24	25	26	27	28		

**NOTE:** Impact Assembly #59 comes completely assembled and lubricated.

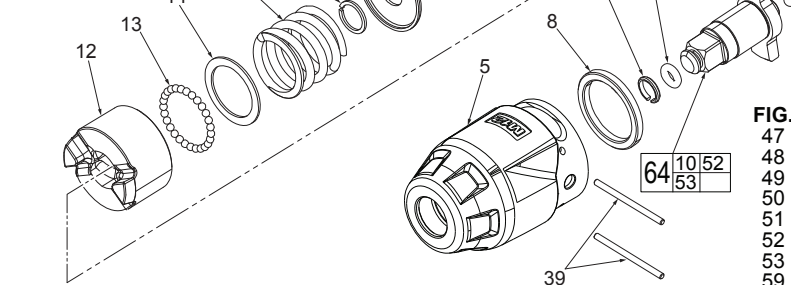

FIG.	PART NO.	DESCRIPTION OF PART	NO. REQ.
29	-----	Motor Pinion	(1)
30	-----	M3.0 Screw	(2)
31	-----	Lock Washer	(2)
32	-----	Motor Mounting Bracket	(1)
33	-----	Motor	(1)
34	-----	Switch	(1)
36	-----	Battery Contact Plate	(1)
37	-----	PCBA	(1)
38	06-65-0022	M2.5 x 30mm Pin	(2)
39	06-65-0502	M2.5 x 36.7mm Pin	(2)
40	-----	Left Handle Halve	(1)
41	-----	Belt Clip	(1)
42	-----	M3.0 Screw	(1)
43	42-70-0055	Housing Clip	(1)
44	-----	LED Lens	(1)
45	45-24-0077	Forward/Reverse Shuttle	(1)
46	40-50-1135	Spring Plate	(1)

FIG.	PART NO.	DESCRIPTION OF PART	NO. REQ.
47	-----	Right Handle Halve	(1)
48	31-01-0003	Light Pipe	(1)
49	06-82-1080	M3 x 14mm Pan Hd. Plast. T-10 Screw	(5)
50	06-82-6350	M3 x 16mm Pan Hd. Plast. T-10 Screw	(1)
51	06-82-7336	M3 x 20mm Pan Hd. Plast. T-10 Screw	(1)
52	34-40-1885	O-Ring - 3/8" Square Anvil	(1)
53	44-90-1050	Friction Ring - 3/8" Square Anvil	(1)
59	14-29-0032	Impact Assembly	(1)
60	31-50-0005	Handle Set	(1)
61	42-70-0490	Belt Clip Assembly	(1)
62	23-30-0430	Motor Assembly	(1)
63	23-66-0212	Electronics Assembly	(1)
64	42-06-1010	3/8" Square Anvil Assembly	(1)
66	31-50-0315	Handle/Electronics Assembly	(1)
67	12-20-2485	Service Nameplate	(1)
68	10-20-2952	Warning Label	(1)
69	42-55-2461	Carrying Case	(1)

**FIG. LUBRICATION**  
(Type 'J' Grease, No. 49-08-4220):  
5 Coat inside of bushing inside front gearcase with grease.  
10 Lightly coat front washer surface of anvil (10) with grease.  
29 Coat pinion of motor assembly (62) with grease.

MILWAUKEE ELECTRIC TOOL CORPORATION  
13135 W. Lisbon Road, Brookfield, WI 53005  
Drwg. 4