



SERVICE PARTS LIST

BULLETIN NO.
54-26-2520

SPECIFY CATALOG NO. AND SERIAL NO. WHEN ORDERING PARTS			REVISED BULLETIN	DATE
M18™ 3/8" Square Impact Wrench				Nov. 2014
CATALOG NO.	2658-20	STARTING SERIAL NO.	F49A	
			WIRING INSTRUCTION SEE PAGE 3	

EXAMPLE:
Component Parts (Small #) Are Included
When Ordering The Assembly (Large #).

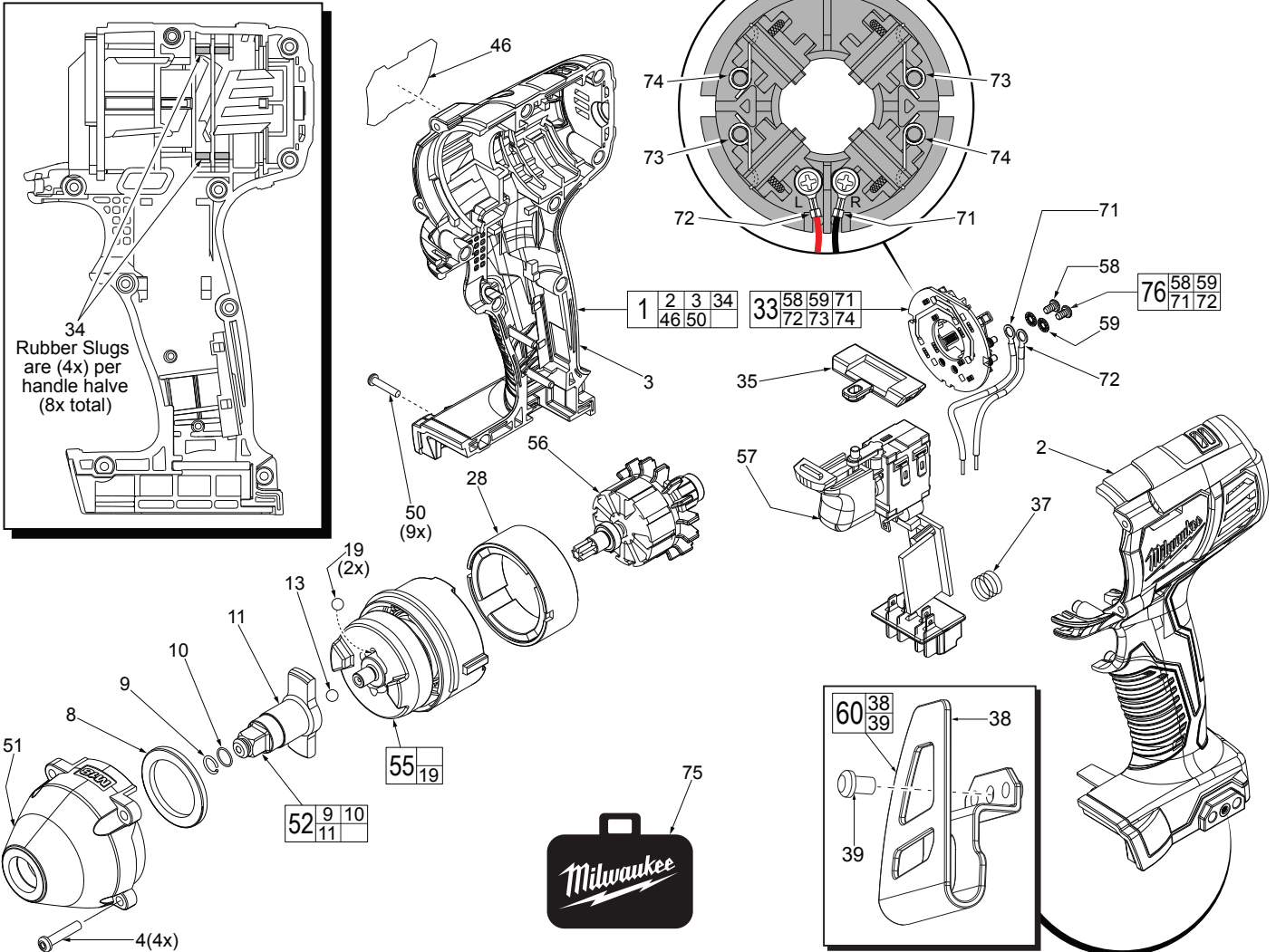

FIG.	PART NO.	DESCRIPTION OF PART	NO. REQ.
1	31-44-1040	Housing Assembly	1
2	-----	Left Housing Halve	1
3	-----	Right Handle Halve	1
4	05-88-0400	M4 x 20mm Pan Hd. T-20 Screw	4
8	45-88-1317	Plastic Washer	1
9	44-90-1050	Friction Ring	1
10	34-40-1885	O-Ring	1
11	-----	3/8" Square Anvil with needle bearing	1
13	02-02-1300	M5 Steel Ball	1
19	02-02-0180	4.7mm Steel Ball	2
28	18-01-3010	Service Field	1
33	22-22-2657	Brush Card Assembly	1
34	45-30-0250	Rubber Slug	8
35	45-24-2657	Forward / Reverse Shuttle	1
37	40-50-1090	Terminal Block Spring	1
38	-----	Belt Clip	1
39	06-82-0130	6-32 x 5/16" Pan Hd. T-15 Mach. Screw	1
46	12-20-2622	Service Nameplate	1
50	06-82-6350	M3 x 16mm Pan Hd. T-10 ST Screw	9
51	28-50-0060	Front Gearcase with Bushing	1
52	42-06-0075	3/8" Square Anvil Assembly with Bearing	1
55	14-30-0115	Gearbox Assembly	1

FIG.	PART NO.	DESCRIPTION OF PART	NO. REQ.
56	16-01-3010	Service Armature Assembly	1
57	23-66-2659	Electronics Assembly Consisting of On-Off Switch, PCBA, Battery Connector Block and LED	1
58	05-88-0926	M3 x 5mm Pan Hd. T-10 Screw	2
59	45-88-1980	Spring Washer	2
60	42-70-2653	Belt Clip Assembly	1
71	-----	Leadwire Assembly - Black - Right Side	1
72	-----	Leadwire Assembly - Red - Left Side	1
73	-----	Brush Spring - Right	2
74	-----	Brush Spring - Left	2
75	42-55-2762	Carrying Case	1
76	14-46-2394	Leadwire/Screw/Washer Kit	1
77	10-20-1126	Warning Label (Not Shown)	1

MILWAUKEE ELECTRIC TOOL CORPORATION
13135 W. Lisbon Road, Brookfield, WI 53005
Drwg. 3