



SERVICE PARTS LIST

BULLETIN NO.
54-16-4022

| | | | |
|---------------------------------------------------------------|----------------------------|------------------------------------------------|--------------------------|
| SPECIFY CATALOG NO. AND SERIAL NO. WHEN ORDERING PARTS | | REVISED BULLETIN 54-16-4021 | DATE Mar. 2008 |
| TWO SPEED DYMODRILL | | | |
| CATALOG NO. 4079 | STARTING SERIAL NO. | 738B | |
| | | WIRING INSTRUCTION 58-01-0930 | |

EXAMPLE:
Component Parts (Small #)
Are Included When Ordering
The Assembly (Large #).

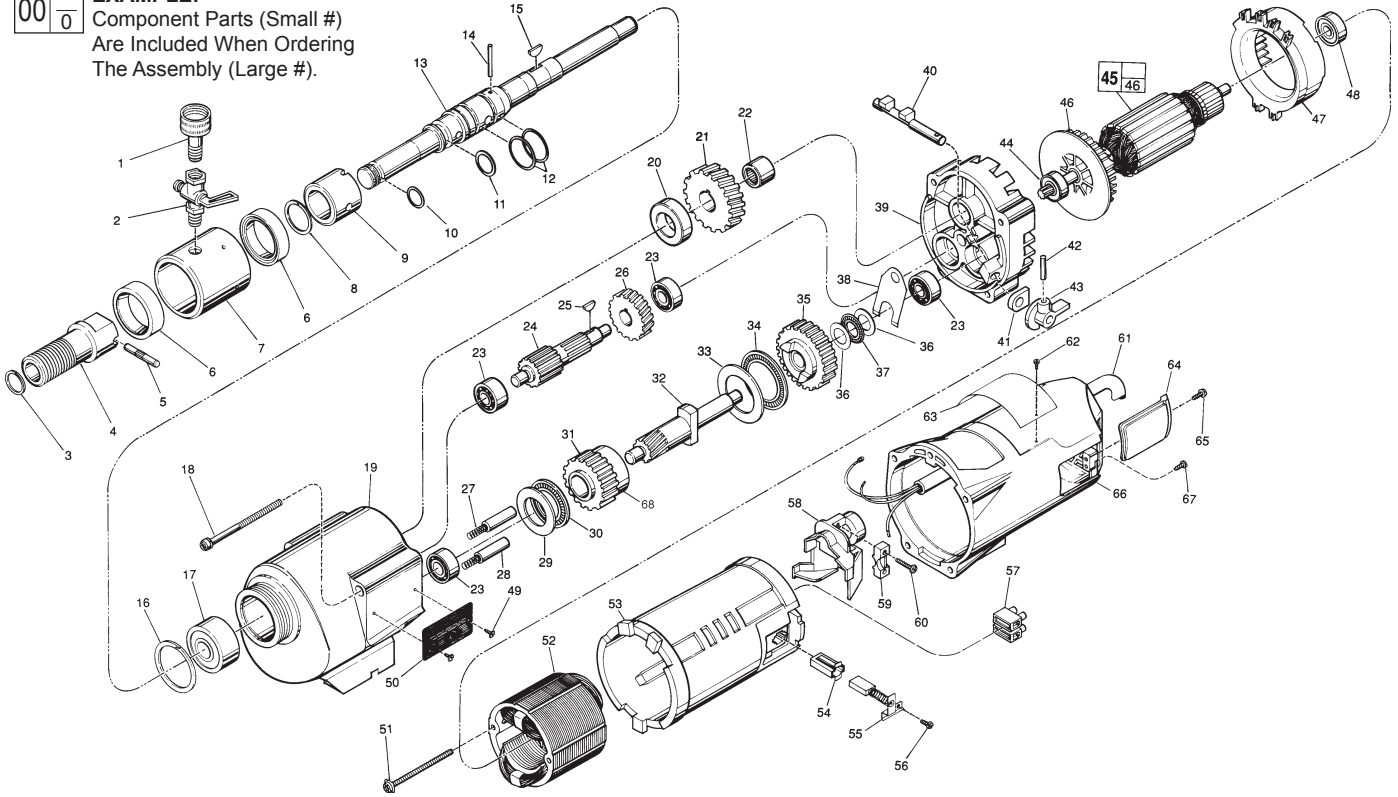

| FIG. | PART NO. | DESCRIPTION OF PART | NO. REQ. |
|------|------------|--------------------------------------|----------|
| 1 | 42-04-0600 | Water Hose Adapter | (1) |
| 2 | 45-80-0060 | Shut Off Valve | (1) |
| 3 | 34-60-1800 | Retaining Ring | (1) |
| 4 | 45-22-0050 | Spindle Sleeve | (1) |
| 5 | 44-60-0032 | Shear Pin | (1) |
| 6 | 45-06-0050 | Trostel Seal | (2) |
| 7 | 43-76-0051 | Water Swivel Hsg Incl 06-83-2430 Scr | (1) |
| 8 | 34-60-2115 | Retaining Ring | (1) |
| 9 | 42-40-0830 | Spindle Bushing | (1) |
| 10 | 34-40-1100 | O-Ring | (1) |
| 11 | 34-40-1200 | O-Ring | (1) |
| 12 | 34-40-1350 | O-Ring | (2) |
| 13 | 38-50-4555 | Spindle | (1) |
| 14 | 06-65-1530 | 1/8 x 1/2" Roll Pin | (1) |
| 15 | 06-42-2400 | Woodruff Key | (1) |
| 16 | 34-80-3800 | Retaining Ring | (1) |
| 17 | 02-20-2515 | Ball Bearing | (1) |
| 18 | 06-82-9202 | 1/4-20 x 4-1/4" Taptite T-30 Screw | (4) |
| 19 | 28-14-1870 | Gear Case Assy Incl 06-65-1535 Pin | (1) |
| 20 | 45-36-1245 | Spindle Spacer | (1) |
| 21 | 32-75-2661 | Spindle Gear | (1) |
| 22 | 02-50-4830 | Needle Bearing | (1) |
| 23 | 02-04-1205 | Ball Bearing | (4) |
| 24 | 36-66-3751 | Pinion Shaft Assembly | (1) |
| 25 | 06-42-1600 | Woodruff Key | (1) |
| 26 | 32-40-1581 | Intermediate Gear | (1) |
| 27 | 40-50-6300 | Shifting Spring | (2) |
| 28 | 44-70-0100 | Shifting Plunger | (2) |
| 29 | 45-88-0520 | Thrust Bearing Washer | (1) |
| 30 | 02-80-1800 | Thrust Bearing | (1) |
| ★ 31 | 32-10-0060 | Clutch Gear Assembly | (1) |
| 32 | 36-14-0720 | Clutch Pinion Shaft | (1) |
| 33 | 45-88-0530 | Thrust Bearing Washer | (1) |
| 34 | 02-80-5000 | Thrust Bearing | (1) |
| 35 | 32-10-0051 | Clutch Gear Assembly | (1) |
| 36 | 45-88-0510 | Thrust Bearing Washer | (2) |
| 37 | 02-80-1200 | Thrust Bearing | (1) |
| 38 | 45-98-0090 | Shifting Yoke | (1) |
| 39 | 14-13-0210 | Diaphragm Assy.(Inc.06-65-1155 Pin) | (1) |
| 40 | 30-15-0272 | Shift Cam | (1) |
| 41 | 43-44-0580 | Foam Gasket | (2) |
| 42 | 06-65-0840 | 1/8 x 3/4" Groove Pin | (1) |
| 43 | 25-60-0056 | Shifting Knob | (1) |

| FIG. | PART NO. | DESCRIPTION OF PART | NO. REQ. |
|------|------------|----------------------------------------|----------|
| 44 | 02-04-1229 | Ball Bearing | (1) |
| 45 | 16-70-0320 | Armature | (1) |
| 46 | 22-84-0790 | Fan | (1) |
| 47 | 42-14-0291 | Baffle | (1) |
| 48 | 02-04-1041 | Ball Bearing | (1) |
| 49 | 06-82-5266 | 4-40 x 1/4" Pan Hd. Taptite T-10 | (2) |
| 50 | 12-98-2100 | Instruction Plate | (1) |
| 51 | 06-82-9152 | 10-24 x 2-3/4" Pan Hd. Sem. T-25 | (2) |
| 52 | 18-70-0290 | 120 V. Field | (1) |
| 53 | 23-16-1410 | Motor Insulator | (1) |
| 54 | 22-20-0680 | Brush Tube | (2) |
| 55 | 22-18-0702 | Carbon Brush Assembly | (2) |
| 56 | 06-82-8835 | 8-32 x 5/16" Pan Hd. Sem. T-20 | (2) |
| 57 | 22-56-0470 | Terminal Block | (1) |
| 58 | 22-38-0140 | Wire Trap | (1) |
| 59 | 31-17-0200 | Cord Clamp | (1) |
| 60 | 06-82-7326 | 8-16 x 1" Pan Hd. Plastite T-20 | (2) |
| ★ 61 | 22-64-0300 | Cord Set | (1) |
| 62 | 06-72-1720 | Service Rivet | (2) |
| 63 | 12-99-1875 | Service Nameplate | (1) |
| 64 | 22-32-0350 | Brush Cover | (2) |
| 65 | 06-82-5316 | 8-32 x 1/2" Pan Hd. Slit. Taptite T-20 | (2) |
| 66 | 28-50-6360 | Motor Housing | (1) |
| 67 | 06-95-5200 | 8-32 x 5/16" Slit. Hex Hd. Screw | (1) |
| ★ 68 | 45-36-0225 | Gear Spacer | (1) |
| | 45-88-0800 | Water Hose Washer (For Fig. No. 1) | (1) |
| | 49-96-4700 | 1-3/8" Open Wrench | (1) |
| | 61-30-0060 | Water Seal Jig | (1) |

FOR MOUNTING DRILL MOTOR USE:

| | | |
|------------|--------------------------------|-----|
| 06-75-3090 | 1/4 20 x 7/8" Socket Hd. Screw | (4) |
| 06-97-4050 | 1/4" Split Ring Lock Washer | (4) |

FIG. LUBRICATION

19 20 Oz. Type "J" Grease, No.49-08-4220

MILWAUKEE ELECTRIC TOOL CORPORATION
13135 W. LISBON RD., BROOKFIELD, WI 53005
Drwg. 2