



# SERVICE PARTS LIST

**BULLETIN NO.**  
**54-16-4042**

SPECIFY CATALOG NO. AND SERIAL NO. WHEN ORDERING PARTS		REVISED BULLETIN	DATE
<b>TWO SPEED DYMODRILL</b>		54-16-4041	Mar. 2008
CATALOG NO.	4094	WIRING INSTRUCTION	
STARTING SERIAL NO.	740B	<b>58-01-0930</b>	

**EXAMPLE:**  
Component Parts (Small #)  
Are Included When Ordering  
The Assembly (Large #).

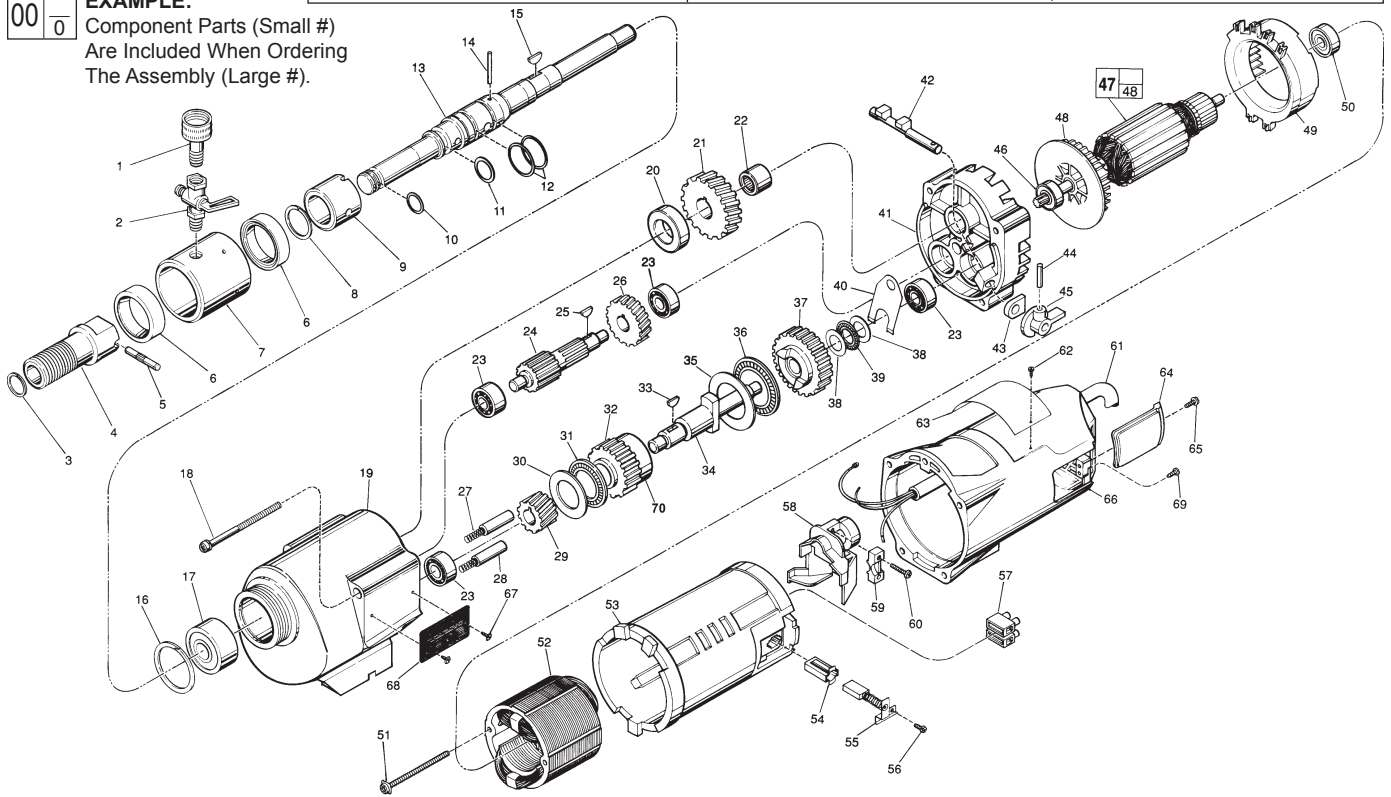

FIG.	PART NO.	DESCRIPTION OF PART	NO. REQ.	FIG.	PART NO.	DESCRIPTION OF PART	NO. REQ.
1	42-04-0600	Water Hose Adapter	(1)	44	06-65-0840	1/8 x 3/4" Groove Pin	(1)
2	45-80-0060	Shut Off Valve	(1)	45	25-60-0056	Shifting Knob	(1)
3	34-60-1800	Retaining Ring	(1)	46	02-04-1229	Ball Bearing	(1)
4	45-22-0050	Spindle Sleeve	(1)	47	16-70-0320	120 V Armature	(1)
5	44-60-0032	Shear Pin	(1)	48	22-84-0790	Fan	(1)
6	45-06-0050	Trostell Seal	(2)	49	42-14-0291	Baffle	(1)
7	43-76-0051	Water Swivel Hsg Incl 06-83-2430 Scr	(1)	50	02-04-1041	Ball Bearing	(1)
8	34-60-2115	Retaining Ring	(1)	51	06-82-9152	10-24 x 2-3/4" Pan Hd. Sem. T-25	(2)
9	42-40-0830	Spindle Bushing	(1)	52	18-70-0290	120 V. Field	(1)
10	34-40-1100	O-Ring	(1)	53	23-16-1410	Motor Insulator	(1)
11	34-40-1200	O-Ring	(1)	54	22-20-0680	Brush Tube	(2)
12	34-40-1350	O-Ring	(1)	55	22-18-0702	Carbon Brush Assembly	(2)
13	38-50-4555	Spindle	(1)	56	06-82-8835	8-32 x 5/16" Pan Hd. Sem.T-20	(2)
14	06-65-1530	1/8 x 1/2" Roll Pin	(1)	57	22-56-0470	Terminal Block	(1)
15	06-42-2400	Woodruff Key	(1)	58	22-38-0140	Wire Trap	(1)
16	34-80-3800	Retaining Ring	(1)	59	31-17-0200	Cord Clamp	(1)
17	02-20-2515	Ball Bearing	(1)	60	06-82-7326	8-16 x 1" Pan Hd. Plastite T-20	(2)
18	06-82-9202	1/4-20 x 4-1/4" Taptite T-30	(4)	★ 61	22-64-0300	Cord Set	(1)
19	28-14-1870	Gear Case Assy. Incl 06-65-1535 Pin	(1)	62	06-72-1720	Service Rivet	(2)
20	45-36-1245	Spindle Spacer	(1)	63	12-99-1875	Service Nameplate	(1)
21	32-75-2521	Spindle Gear	(1)	64	22-32-0350	Brush Cover	(2)
22	02-50-4830	Needle Bearing	(1)	65	06-82-5316	8-32 x 1/2" Pan Hd. Slit. Taptite T-20	(2)
23	02-04-1205	Ball Bearing	(4)	66	28-50-6360	Motor Housing	(1)
24	36-66-3751	Pinion Shaft Assy.	(1)	67	06-82-5266	4-40 x 1/4" Pan Hd. Taptite T-10	(2)
25	06-42-1600	Woodruff Key	(1)	68	12-98-2100	Instruction Plate	(1)
26	32-40-1581	Intermediate Gear	(1)	69	06-95-5200	8-32 x 5/16" Slotted Hex Hd. Screw	(1)
27	40-50-6300	Shifting Spring	(2)	★ 70	45-36-0225	Gear Spacer	(1)
28	44-70-0100	Shifting Plunger	(2)		49-96-4700	1-3/8" Open End Wrench	(1)
29	32-60-1041	Pinion Gear	(1)		45-88-0800	Water Hose Washer (For Fig. No. 1)	(1)
30	45-88-0520	Thrust Bearing Washer	(1)		61-30-0060	Water Seal Jig	(1)
31	02-80-1800	Thrust Bearing	(1)				
★ 32	32-10-0060	Clutch Gear Assembly	(1)				
33	06-42-2000	Woodruff Key	(1)				
34	36-14-0061	Clutch Shaft	(1)				
35	45-88-0530	Thrust Bearing Washer	(1)				
36	02-80-5000	Thrust Bearing	(1)				
37	32-10-0051	Clutch Gear Assembly	(1)				
38	45-88-0510	Thrust Bearing Washer	(2)				
39	02-80-1200	Thrust Bearing	(1)				
40	45-98-0090	Shifting Yoke	(1)				
41	14-13-0210	Diaphragm Assy.(Inc. 06-65-1155 Pin)	(1)				
42	30-15-0272	Shift Cam	(1)				
43	43-44-0580	Foam Gasket	(2)				

**FOR MOUNTING DRILL MOTOR USE:**  
06-75-3090 1/4-20 x 7/8" Socket Hd. Screw (4)  
06-97-4050 1/4" Split Ring Lock Washer (4)

**FIG. LUBRICATION**  
19 20 Oz. Type "J" Grease, No. 49-08-4220.

**MILWAUKEE ELECTRIC TOOL CORPORATION**  
13135 W. LISBON RD., BROOKFIELD, WI 53005  
Drwg. 2