

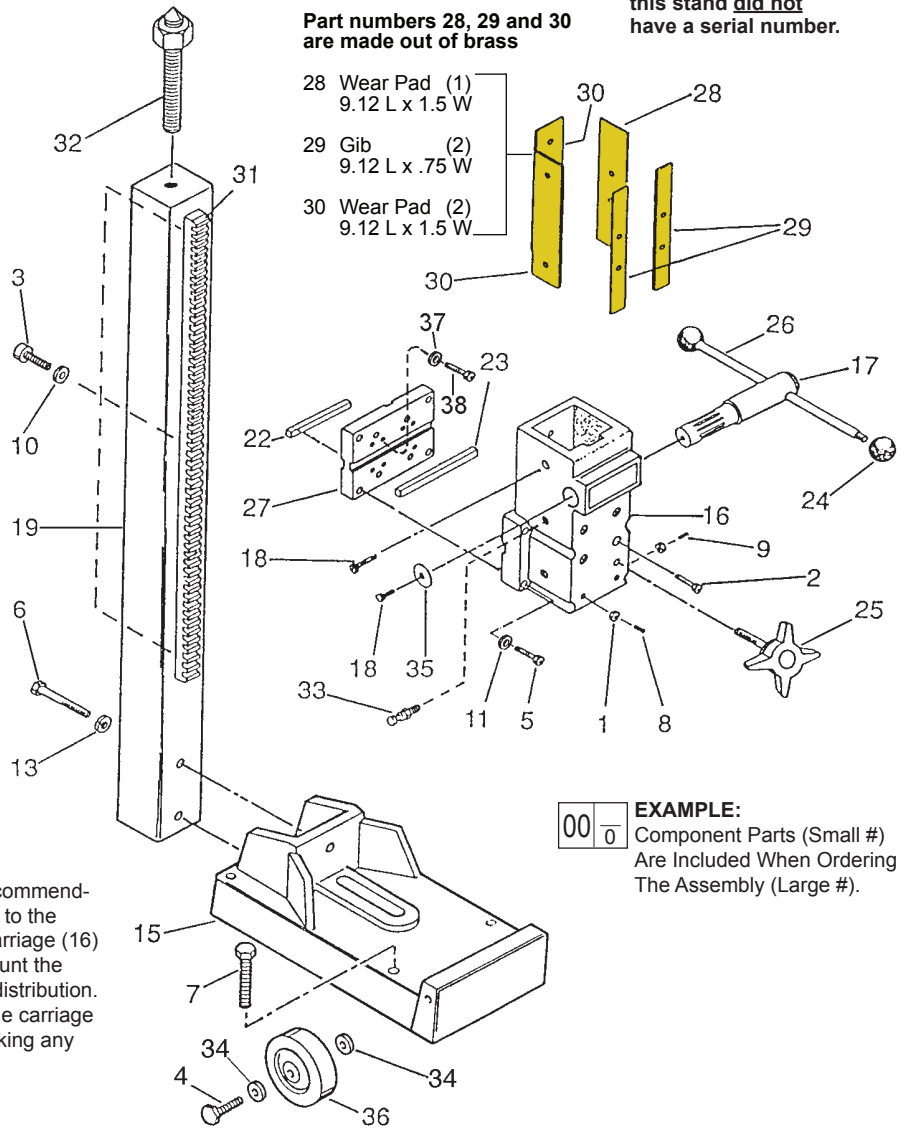

# SERVICE PARTS LIST

**BULLETIN NO.**  
**54-46-1325**

SPECIFY CATALOG NO. AND SERIAL NO. WHEN ORDERING PARTS		REVISED BULLETIN	DATE
<b>SMALL BASE DYMORIG</b>			July 2013
CATALOG NO. <b>4115</b>	STARTING SERIAL NO. <b>A08A*</b>	WIRING INSTRUCTION	

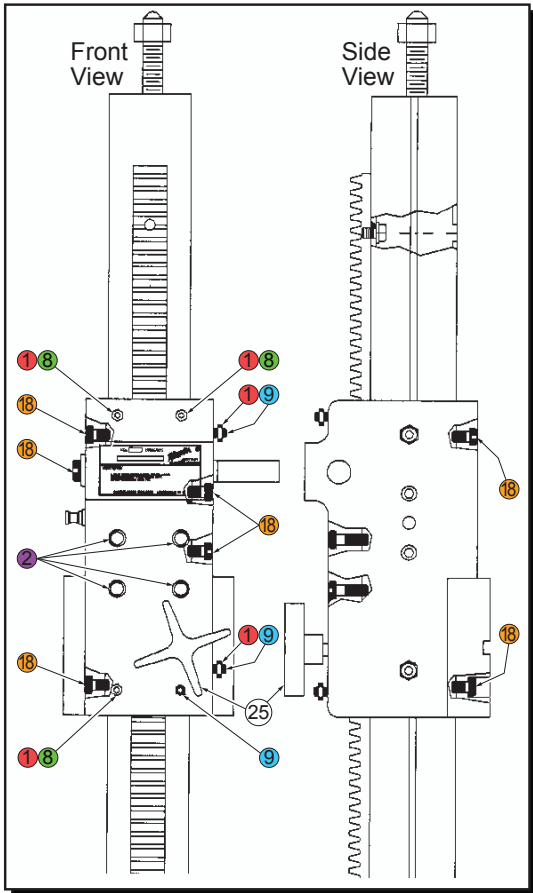

To properly install Wear Pads and Gibs (28,29,30), it is recommended to clean Fasteners (2,8,9,18) and to apply Red Loctite® to the threads. Once the wear pads and gibs are in place, the Carriage (16) has to be adjusted to the Column (19). It is beneficial to mount the drill motor to the stand for proper carriage/column weight distribution. Carriage Screw (25) can be tightened slightly to prevent the carriage and drill motor from traveling down the column prior to making any screw adjustments.

**EXAMPLE:**  

00	0
----	---

 Component Parts (Small #)  
 Are Included When Ordering  
 The Assembly (Large #).

FIG.	PART NO.	DESCRIPTION OF PART	NO. REQ.	FIG.	PART NO.	DESCRIPTION OF PART	NO. REQ.
1	06-55-1525	1/4-20 Hex Nut	(5)	25	43-98-0525	Carriage Screw	(1)
2	06-75-3050	1/4-20 x 3/4" Socket Hd. Screw	(4)	26	44-10-0365	Bar Handle	(1)
3	06-75-3920	5/16-18 Socket Hd. Screw	(3)	27	44-34-0190	Motor Mount	(1)
4	06-75-0970	1/2" Hex Hd. Cap Screw	(2)	28	44-52-0605	Wear Pad	(1)
5	06-75-5840	3/8-16 Socket Hd. Cap Screw	(4)	★ 29	44-52-0665	Gib	(2)
6	06-75-5845	5/8-11 Hex Hd. Cap Screw	(2)	★ 30	44-52-0675	Wear Pad	(2)
★ 7	06-83-5150	5/8-11 x 4-1/2" Hex Head Cap Screw	(4)	31	44-80-0175	Rack	(1)
8	06-83-6010	1/4-20 x 1-1/2" Set Screw	(3)	32	45-04-0535	Jack Screw Assembly	(1)
9	06-83-6020	1/4-20 x 1" Set Screw	(3)	33	45-58-0280	Mounting Stud	(1)
10	06-97-4110	5/16" Split Ring Lockwasher	(3)	34	45-88-7460	1/2" Flat Washer	(4)
11	06-97-4127	Lockwasher	(4)	35	45-88-8675	Shaft Washer	(1)
13	06-97-4400	5/8" Split Ring Lockwasher	(2)	36	45-94-0135	Wheel	(2)
14	12-99-1310	Nameplate Blank	(1)	★ 37	06-97-4050	1/4" Lockwasher	(4)
15	28-06-1110	Small Base	(1)	★ 38	06-75-3090	1/4-20 x 7/8" Screw	(4)
★ 16	28-23-3415	Carriage	(1)		49-96-0060	1/8" Hex Key	(1)
17	36-66-4620	Pinion Shaft	(1)		49-96-0080	3/16" Hex Key	(1)
18	06-75-2950	1/4-20 x 1/2" Socket Hd. Cap Screw	(7)		49-96-0120	5/16" Hex Key	(1)
19	42-78-0050	Column	(1)				
22	43-96-0200	3/8 x 3/8 x 3" Key	(1)				
23	43-96-0210	3/8 x 3/8 x 5" Key	(1)				
24	43-98-0050	Plastic Knob	(2)				

**MILWAUKEE ELECTRIC TOOL CORPORATION**  
 13135 W. LISBON RD., BROOKFIELD, WI 53005  
 Drwg. 5