



SERVICE PARTS LIST

**BULLETIN NO.
54-24-5440**

SPECIFY CATALOG NO. AND SERIAL NO. WHEN ORDERING PARTS		REVISED BULLETIN	DATE
14 lb. (6,4 kg) SDS-MAX DEMOLITION HAMMER			Sept. 2014
CATALOG NO. 5446-21	STARTING SERIAL NO. B39A	WIRING INSTRUCTION 58-01-5400	

EXAMPLE:
Component Parts (Small #) Are Included
When Ordering The Assembly (Large #).

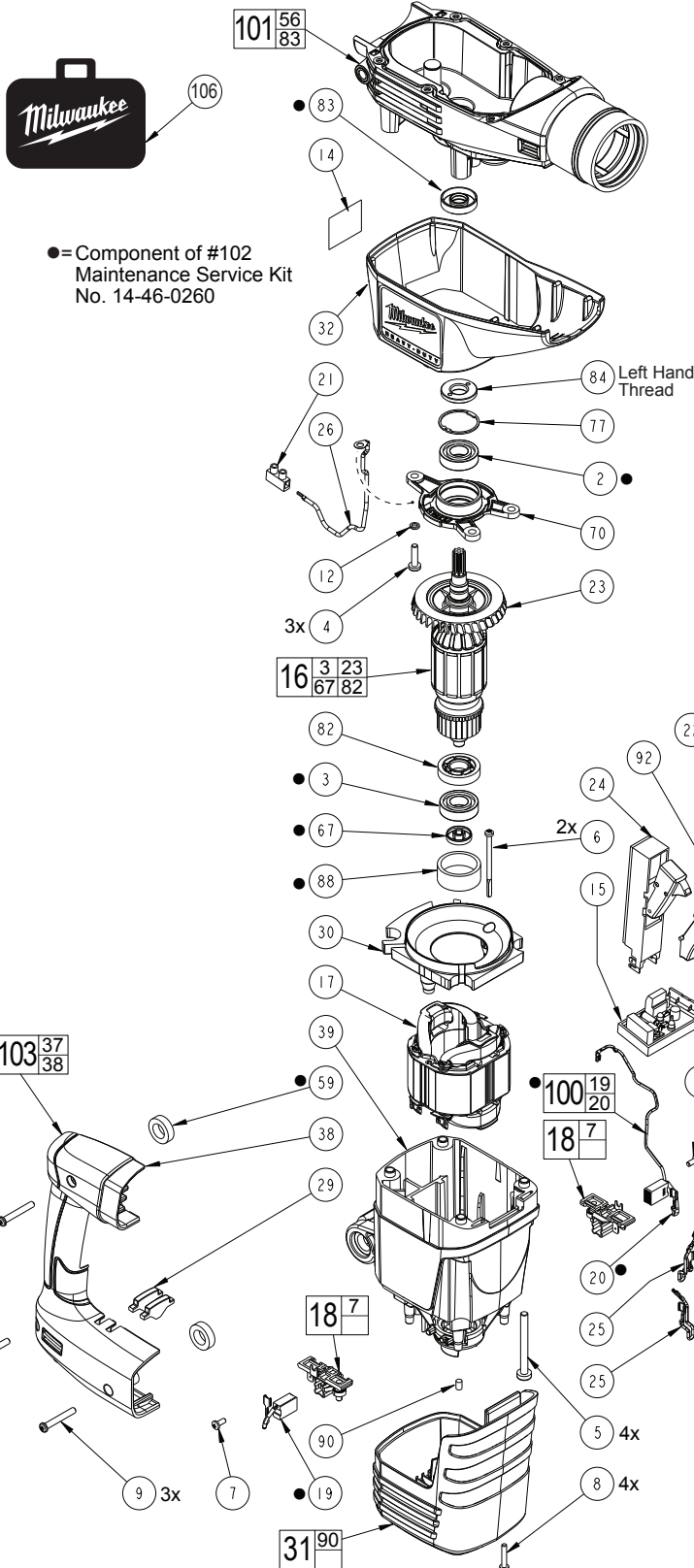

FIG.	PART NO.	DESCRIPTION OF PART	NO. REQ.
2	02-04-0140	● Ball Bearing	(1)
3	02-04-0150	● Ball Bearing	(1)
4	05-74-0060	M5 x 20 Taptite T-25 Screw	(3)
5	05-74-0070	M6 x 60 Taptite T-30 Screw	(4)
6	05-74-0240	M4 x 64 Plastite T-20 Screw	(2)
7	05-74-0250	M9 x 9.5 T-15 Screw	(4)
8	05-74-0270	H-K4 x 22 T-15 Screw	(4)
9	05-74-0280	M5 x 35 T-20 Screw	(3)
12	05-90-0190	M5 Spring Washer	(1)
14	12-20-5400	Service Nameplate Kit	(1)
15	14-20-0340	PC Board	(1)
16	16-50-0120	Service Armature Assembly	(1)
17	18-50-0120	Service Field Assembly	(1)
18	22-20-0050	Brush Holder Assembly	(2)
19	-----	● Carbon Brush Assembly	(1)
20	-----	● Carbon Brush Assembly (2 wire)	(1)
21	22-56-0010	Terminal Block	(1)
22	22-64-0880	Power Cord	(1)
23	22-84-0010	Fan	(1)
24	23-66-0033	Switch	(1)
25	23-94-0110	Wire Harness	(2)
26	23-94-0430	Grounding Wire Harness	(1)
27	23-94-0018	Jumper Wire (See Bulletin 58-01-5400)	(1)
29	31-01-0090	Light Pipe	(2)
30	31-05-0140	Fan Baffle	(1)
31	31-12-0070	Motor Cap	(1)
32	31-12-0260	Shroud	(1)
35	31-17-0290	Cord Clamp	(1)
37	-----	Handle Halve-Left	(1)
38	-----	Handle Halve-Right	(1)
39	31-50-0100	Motor Housing	(1)

**SEE PAGE 3 FOR
LUBRICATION AND
SERVICE NOTES**

FIG.	PART NO.	DESCRIPTION OF PART	NO. REQ.
59	42-42-0031	● Bushing	(4)
67	44-26-0090	● Magnetic Disc	(1)
70	44-66-0220	Bearing End Plate	(1)
73	44-76-0320	● Cord Protector	(1)
77	44-90-0080	Internal Retaining Ring	(1)
82	45-06-0020	Dust Seal	(1)
83	45-06-0030	● Armature Seal	(1)
84	45-06-0120	Seal Ring-Left Hand Thread	(1)
88	45-22-0110	● Rubber Sleeve	(1)
90	45-30-0055	● Rubber Plug	(1)
92	45-72-0020	Trigger	(1)
100	14-46-0275	● Brush Service Kit	(1)
101	14-46-0355	Gearcase Service Kit	(1)
102	14-46-0290	Maintenance Service Kit	(1)
103	14-46-0215	Handle Service Kit	(1)
106	42-55-0190	Accessory Carrying Case	(1)

MILWAUKEE ELECTRIC TOOL CORPORATION
13135 W. LISBON RD., BROOKFIELD, WI 53005
Drwg. 6