



SERVICE PARTS LIST

BULLETIN NO.
54-32-1284

SPECIFY CATALOG NO. AND SERIAL NO. WHEN ORDERING PARTS		REVISED BULLETIN	DATE
7" HEAVY-DUTY VARIABLE SPEED POLISHER		54-32-1283	June 2006
CATALOG NO.	5460	WIRING INSTRUCTION	
		58-01-0225	
STARTING SERIAL NO.	785C		

EXAMPLE:
Component Parts (Small #) Are Included
When Ordering The Assembly (Large #).

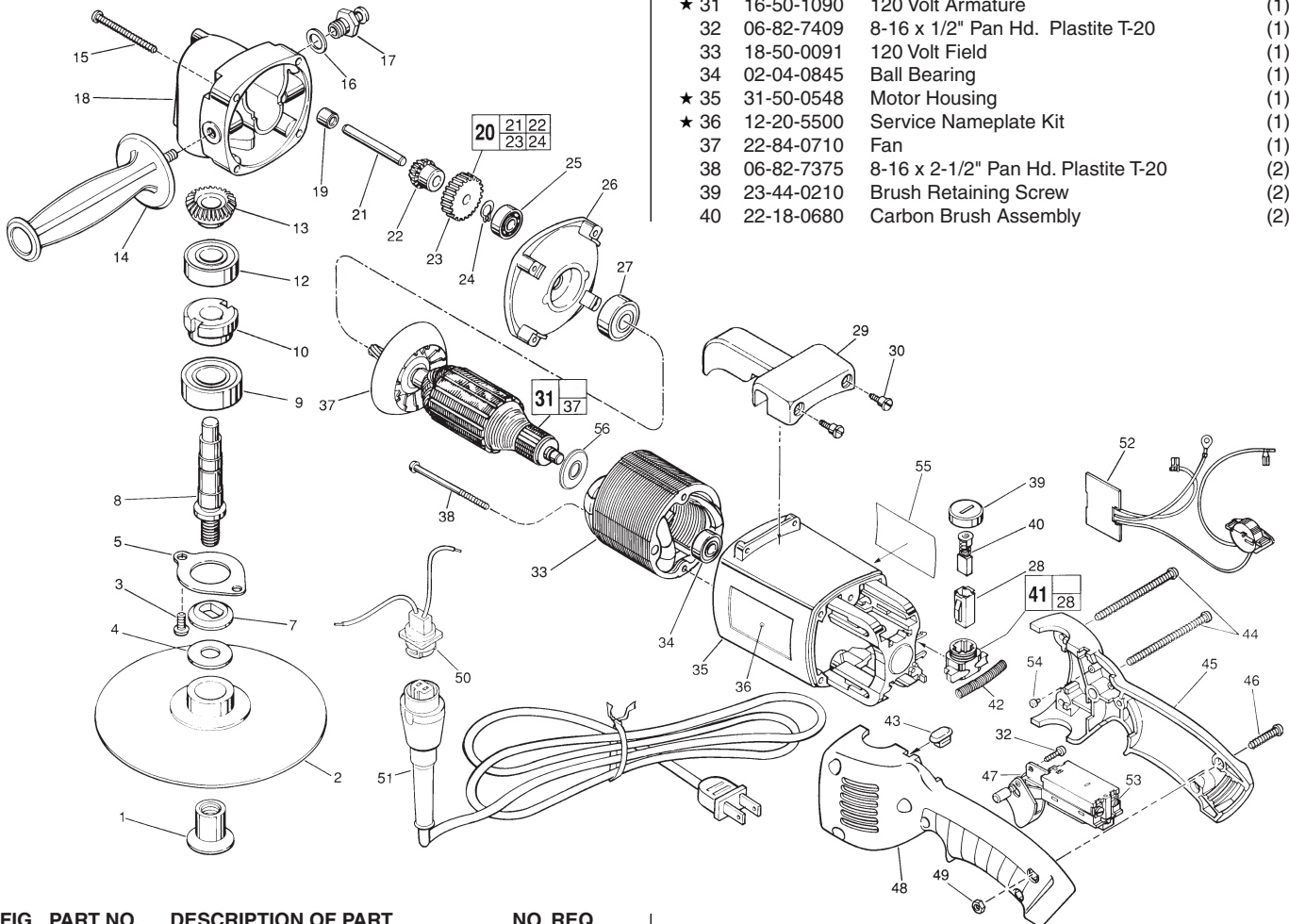

FIG. PART NO.	DESCRIPTION OF PART	NO. REQ.
29	31-70-0110 Tool Rest	(1)
30	45-04-0720 Shoulder Screw	(3)
★ 31	16-50-1090 120 Volt Armature	(1)
32	06-82-7409 8-16 x 1/2" Pan Hd. Plastite T-20	(1)
33	18-50-0091 120 Volt Field	(1)
34	02-04-0845 Ball Bearing	(1)
★ 35	31-50-0548 Motor Housing	(1)
★ 36	12-20-5500 Service Nameplate Kit	(1)
37	22-84-0710 Fan	(1)
38	06-82-7375 8-16 x 2-1/2" Pan Hd. Plastite T-20	(2)
39	23-44-0210 Brush Retaining Screw	(2)
40	22-18-0680 Carbon Brush Assembly	(2)

FIG. PART NO.	DESCRIPTION OF PART	NO. REQ.
1	49-40-0390 Disc Nut	(1)
2	49-36-2500 7" Backing Pad	(1)
★ 3	06-82-5338 1/4-20 x 1/2" Pan Hd. Slit. Tapt. T-30	(2)
4	45-88-8465 Spindle Washer	(1)
5	45-88-7785 Spindle Retaining Washer	(1)
7	49-05-0060 Washer Flange	(1)
8	38-50-5231 Spindle Shaft	(1)
9	02-04-2031 Ball Bearing	(1)
10	42-74-0070 Spindle Locking Cog	(1)
12	02-04-1747 Ball Bearing	(1)
13	32-05-1081 Bevel Gear	(1)
★ 14	43-62-1265 Side Handle	(1)
15	06-82-7441 10-14 x 1-7/8" Pan Hd. Slit. Plastite T-25	(4)
16	45-88-5320 Flat Washer	(1)
17	44-20-0211 Spindle Lock Assembly	(1)
18	28-14-1430 Gear Case	(1)
19	02-50-2200 Needle Bearing	(1)
20	14-73-0130 Intermediate Gear Assy.	(1)
21	----- Intermediate Shaft	(1)
22	----- Bevel Gear	(1)
23	----- Intermediate Gear	(1)
24	----- External Retaining Ring	(1)
25	02-04-0910 Ball Bearing	(1)
26	28-28-1565 Diaphragm	(1)
★ 27	02-04-1860 Ball Bearing	(1)
28	22-20-0660 Brush Tube	(2)

FIG. PART NO.	DESCRIPTION OF PART	NO. REQ.
41	22-22-1325 Brush Holder Assembly	(2)
42	40-50-7770 Brush Holder Spring	(2)
43	42-38-0190 Bumper	(1)
44	06-82-2598 10-24 x 2-3/4" Pan Hd. Slit. T-25	(2)
45	31-44-1776 Right Handle Half	(1)
46	06-82-2568 10-24 x 7/8" Pan Hd. Slit. T-25	(3)
47	23-66-1940 TSC Switch	(1)
48	31-44-1771 Left Handle Half	(1)
49	06-55-1050 10-24 Hex Nut	(5)
50	22-56-0675 Blade Housing Assembly	(1)
51	48-76-5010 Cord Set	(1)
★ 52	14-20-1035 Dial / Module Assembly	(1)
★ 53	05-78-0305 Switch Screw	(4)
54	42-38-0181 Rubber Bumper	(2)
★ 55	10-98-1810 Warning Label	(1)
★ 56	23-16-1700 Commutator Insulator	(1)

FIG. LUBRICATION
★ 18 1-1/4 Oz. Type "Y" Grease No. 49-08-5270, In Grease Cavity.
★ 1-1/2 Oz. Type "B" Grease, No. 49-08-0900, To Build Up Wall of Grease Around Grease Cavity.

MILWAUKEE ELECTRIC TOOL CORPORATION
13135 W. LISBON RD., BROOKFIELD, WI 53005
Drwg. 4