



SERVICE PARTS LIST

BULLETIN NO.
54-38-2250

SPECIFY CATALOG NO. AND SERIAL NO. WHEN ORDERING PARTS		REVISED BULLETIN	DATE
6" HP ANGLE GRINDER with PADDLE SWITCH with lock-on			Nov. 2014
CAT. NO.	6161-30	STARTING SERIAL NUMBER	D07A
		WIRING INSTRUCTION See Reverse Side	

FIG.	PART NO.	DESCRIPTION OF PART	NO. REQ.
1	05-88-1650	M4 x 25mm Pan Hd. ST Screw T-20	(4)
2	42-62-0125	Side Handle Assembly	(1)
3	14-30-1155	Gearcase Assembly	(1)
3a	-----	Spindle Lock Button	(1)
3b	-----	Spindle Lock Spring	(1)
3c	-----	Gearcase	(1)
3d	-----	O-Ring	(1)
3e	-----	Spindle Lock Pin	(1)
3f	-----	Needle Bearing	(1)
3g	02-04-0620	Ball Bearing	(1)

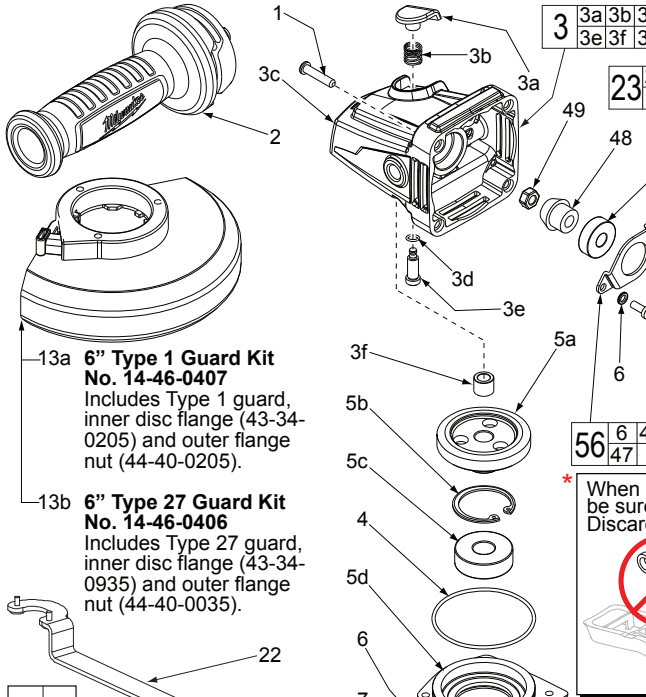

13a 6" Type 1 Guard Kit No. 14-46-0407
Includes Type 1 guard, inner disc flange (43-34-0205) and outer flange nut (44-40-0205).

13b 6" Type 27 Guard Kit No. 14-46-0406
Includes Type 27 guard, inner disc flange (43-34-0935) and outer flange nut (44-40-0035).

EXAMPLE:
Component Parts (Small #)
Are Included When Ordering
The Assembly (Large #).

***LUBRICATION NOTE:**
When servicing Gears (5a & 48) or Gear case (3c), 90-95% of old grease must be removed prior to new grease being added.

FIG. LUBRICATION*
5a,48 Type "Y" Grease, No. 49-08-5270, Must Be Applied To All Gear Teeth.

4	34-40-0560	O-Ring	(1)
5	14-73-0430	Spindle Hub Assembly	(1)
5a	-----	Spiral Bevel Gear	(1)
5b	-----	Retaining Ring	(1)
5c	-----	Ball Bearing	(1)
5d	-----	Spindle Hub	(1)
5e	-----	5/8" Spindle	(1)
6	05-90-0225	Spring Washer	(6)
7	05-88-1210	M4 x 14mm Pan Hd. Mach. Screw T-20	(4)
13	14-32-0225	6" Type 1 Guard Assembly	(1)
13a	14-46-0407	6" Type 1 Guard Service Kit with flanges	(1)
13b	14-46-0406	6" Type 27 Guard Service Kit with flanges	(1)
15	-----	O-Ring	(1)
16	-----	Wavey Spring	(1)
17	-----	Flange with Ramps	(1)
18	-----	Retaining Ring	(1)
19	43-34-0205	6" T1 Inner Flange (For type 1 wheels only)	(1)
21	44-40-0205	6" T1 Outer Flange (For type 1 wheels only)	(1)
22	49-96-7205	Spanner Wrench	(1)
23	31-44-0645	Rear Handle Set	(1)
23a	-----	Left Handle Halve	(1)
23b	-----	Right Handle Halve	(1)
25	44-76-0095	Cord Protector	(1)
26	22-64-3430	Power Cord	(1)

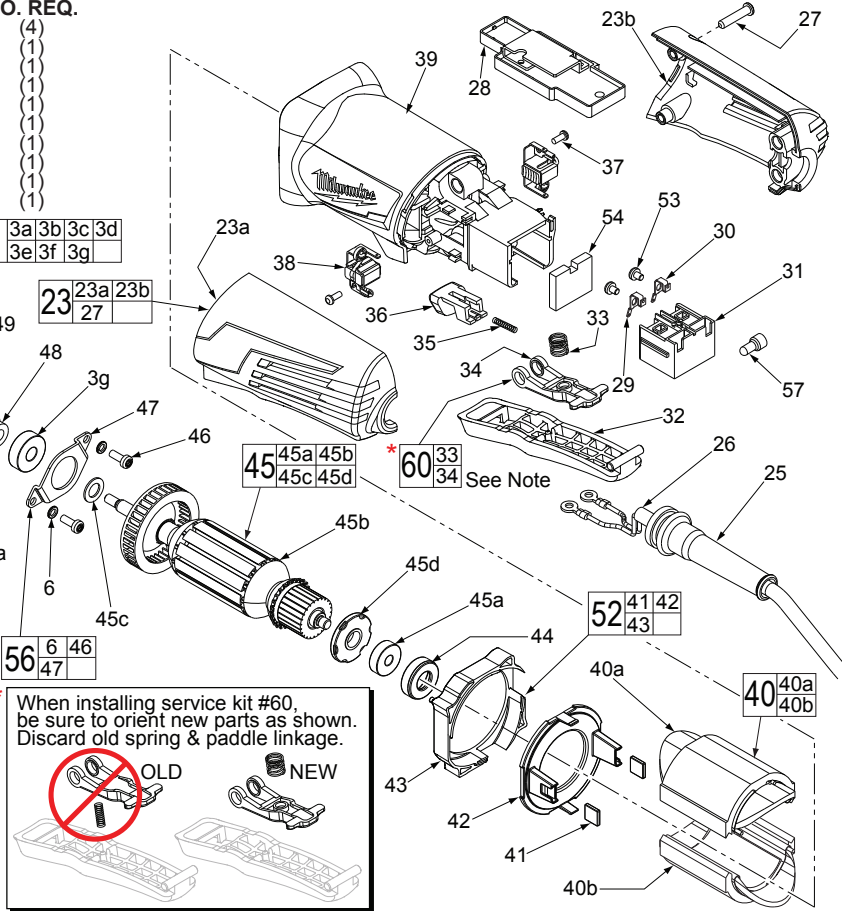

***When installing service kit #60, be sure to orient new parts as shown. Discard old spring & paddle linkage.**

OLD **NEW**

FIG.	PART NO.	DESCRIPTION OF PART	NO. REQ.
27	05-88-1300	M4 x 28mm Pan Hd. ST Screw T-20	(4)
28	22-09-1845	PCB Assembly	(1)
29	23-74-1620	Terminal	(1)
30	23-74-1615	Terminal	(1)
31	23-66-2665	On-Off Switch	(1)
32	31-92-0275	Paddle Trigger	(1)
33	-----	Paddle Trigger Spring	(1)
34	-----	Paddle Linkage	(1)
35	40-50-1155	Lock Button Spring	(1)
36	42-42-0495	Lock-On Button	(1)
37	05-88-0030	M3 x 8.5mm Pan Hd. ST Screw T-10	(2)
38	22-18-2250	Carbon Brush Assembly (Set of 2)	(1)
39	31-50-2165	Motor Housing	(1)
40	18-07-0300	Field Assembly	(1)
40a	-----	Field Halve	(1)
40b	-----	Field Halve	(1)
41	42-28-0085	Rubber Block	(2)
42	-----	Baffle Foot	(1)
43	-----	Baffle	(1)
44	42-96-0016	Rubber Bearing Cap	(1)
45	16-10-0845	Armature Assembly	(1)
45a	02-04-2110	Ball Bearing	(1)
45b	-----	Armature	(1)
45c	45-88-0406	Washer	(1)
45d	-----	Magnetic Disc	(1)
46	05-88-1280	M4 x 10mm Pan Hd. Mach. Screw T-20	(2)
47	44-86-0155	Bearing Retainer	(1)
48	32-60-0305	Pinion	(1)
49	05-55-0620	M5 Hex Nut	(1)
50	14-46-6105	Flange with Ramps Assembly	(1)
52	42-14-0515	Baffle Assembly	(1)
53	05-78-0305	M3.5 x 7mm Pan Hd. Phil. Switch Scr.	(2)
54	23-16-0075	Foam Block	(1)
56	44-86-0145	Bearing Retaining Plate Assembly	(1)
57	22-56-0150	Closed End Wire Connector	(1)
60	14-46-6100	Paddle Linkage/Spring Service Kit	(1)
	12-20-1560	Service Nameplate (Not Shown)	(1)
	10-20-2225	Bi-Lingual Warning Label (Not Shown)	(1)

MILWAUKEE ELECTRIC TOOL CORPORATION
13135 W. Lisbon Road, Brookfield, WI 53005
Drwg. 7