



SERVICE PARTS LIST

BULLETIN NO.
54-40-6532

SPECIFY CATALOG NO. AND SERIAL NO. WHEN ORDERING PARTS		REVISED BULLETIN	DATE
SAWZALL® Reciprocating Saw		54-40-6531	Nov. 2013
CATALOG NO. 6519-30 or 6519-31	STARTING SERIAL NO. C25C	WIRING INSTRUCTION 58-01-0293	

EXAMPLE:
Component Parts (Small #)
Are Included When Ordering
The Assembly (Large #).

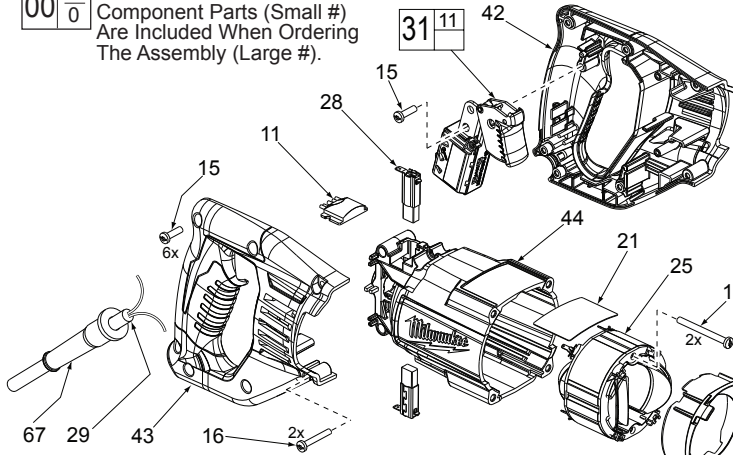
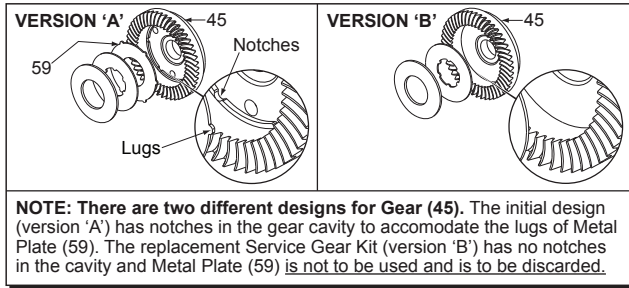

FIG.	PART NO.	DESCRIPTION OF PART	NO. REQ.
45	32-05-0022	Service Gear Kit	(1)
46	34-60-0810	External Retaining Ring	(1)
47	34-60-3700	Retaining Ring	(1)
48	38-50-0076	Spindle	(1)
49	40-50-0596	Disc Spring	(1)
50	40-50-0162	Torsion Spring	(1)
52	42-40-0076	Spacer	(1)
53	42-40-2052	Rollers	(2)
54	42-50-0360	Rear Cam	(1)
55	42-50-0355	Front Cam	(1)

**SEE PAGES 2 & 3
FOR LUBRICATION
AND SPECIAL
SERVICE NOTES**



★ = Part number change from previous service parts list.



FIG.	PART NO.	DESCRIPTION OF PART	NO. REQ.
1	02-04-0845	Ball Bearing	(1)
2	02-04-1020	Ball Bearing (02-04-1021 as an alternate)	(1)
3	02-04-1516	Ball Bearing	(1)
5	02-50-1640	Needle Bearing	(1)
6	05-88-8309	K50 x 35mm Washer Hd. PT T-20 Screw	(4)
7	06-08-0017	Drive Hub Bolt (R.H. Thread)	(1)
8	06-65-0135	Pivot Pin	(2)
10	06-65-0145	Pin - Connecting Rod	(1)
★ 11	-----	Remote Electronics Assembly	(1)
13	06-82-5314	10-24 x .5 Pan Hd. Tapt. T-25 Screw	(4)
14	06-82-5411	10-24 x .625 Pan Hd. Tapt. T-25 Screw	(5)
15	06-82-7270	8-16 x .625 Pan Hd. Slit. Plast. T-20 Screw	(6)
16	06-82-7326	8-16 x 1.00 Pan Hd. Slit. Plast. T-20 Screw	(2)
17	06-82-7410	8-16 x 1.875 Pan Hd. Slit. Plast. T-20 Screw	(2)
18	06-82-8870	1/2-DG50 Thread Form T-20 Screw	(6)
21	12-99-1756	Service Nameplate	(1)
23	16-30-0585	Service Armature	(1)
24	22-84-0531	Fan	(1)
25	18-31-0525	Service Field	(1)
28	22-20-0065	Carbon Brush Assembly	(2)
29	22-64-1622	Cordset	(1)
★ 31	23-66-4205	Switch with Remote Electronics Assembly	(1)
38	28-14-0045	Gearcase - Left	(1)
39	28-14-0046	Gearcase - Right	(1)
40	31-05-0195	Baffle	(1)
41	31-15-0170	Spring Cover	(1)
42	31-44-0810	Handle - Left	(1)
43	31-44-0815	Handle - Right	(1)
44	31-50-0290	Motor Housing	(1)

FIG.	PART NO.	DESCRIPTION OF PART	NO. REQ.
56	14-09-0190	Crankshaft Assembly	(1)
58	43-06-0025	Metal Plate	(1)
59	43-06-0030	Metal Plate (Version 'A' only, see detail)	(1)
60	43-56-0045	Orbit Slot	(1)
62	14-46-1060	Quik-Lok Blade Clamp Kit	(1)
63	44-60-1750	Lock Pin	(1)
64	44-66-0280	Bearing Retaining Plate - Gearcase Bearing	(1)
65	44-66-1070	Bearing Retaining Plate - Armature Bearing	(1)
67	44-76-0210	Cord Protector	(1)
68	14-86-0105	Front Bushing Assembly	(1)
71	45-06-0230	'H' Seal	(1)
73	45-12-2054	Insulator	(1)
76	45-16-0030	Shoe Assembly	(1)
78	45-22-0175	Sleeve	(1)
79	14-30-0145	Left Gearcase Assembly	(1)
80	14-30-0146	Right Gearcase Assembly	(1)
83	42-55-2051	Carrying Case	(1)
	23-94-0510	Leadwire Assembly - Black (Not Shown)	(1)
	23-94-0520	Leadwire Assembly - White (Not Shown)	(1)

MILWAUKEE ELECTRIC TOOL CORPORATION
13135 W. Lisbon Road, Brookfield, WI 53005
Drwg. 2