



SERVICE PARTS LIST

BULLETIN NO.
54-44-0626

SPECIFY CATALOG NO. AND SERIAL NO. WHEN ORDERING PARTS		REVISED BULLETIN 54-44-0625	DATE Dec. 2008
14 GAUGE SHEAR			
CATALOG NO. 6815	STARTING SERIAL NO. 710D	WIRING INSTRUCTION 58-01-0309	

EXAMPLE:

00	0
----	---

 Component Parts (Small #)
 Are Included When Ordering
 The Assembly (Large #).

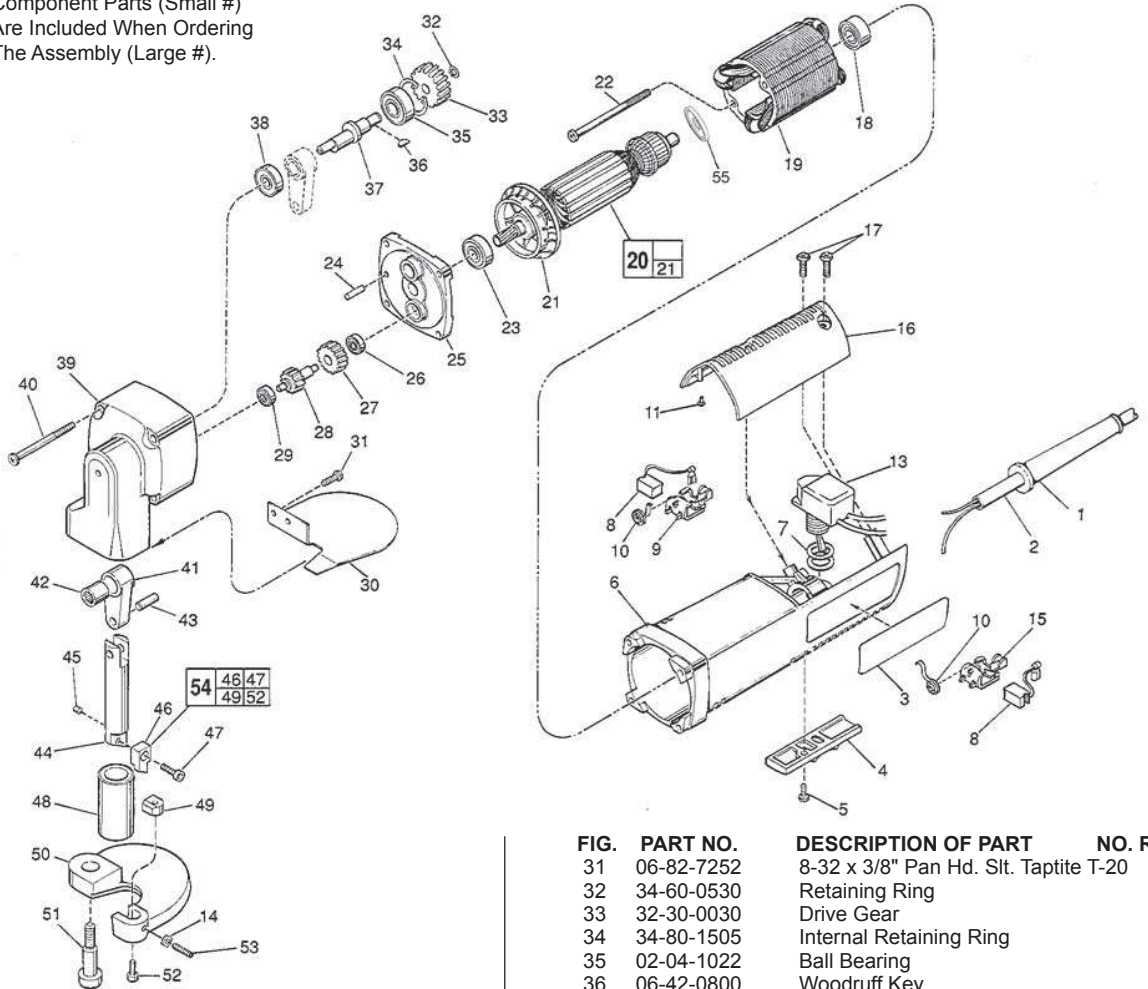

FIG.	PART NO.	DESCRIPTION OF PART	NO. REQ.
	1	44-76-0130 Cord Protector	(1)
	2	22-64-0215 Cord Set	(1)
	3	12-20-0540 Service Nameplate Kit	(1)
	4	31-55-0156 Trigger Cover	(1)
	5	06-82-7409 8-16 x 1/2" Pan Hd. Slit. Plastite T-20	(1)
	6	31-50-0426 Motor Housing	(1)
	7	34-40-4015 O-Ring	(2)
	8	22-18-0710 Carbon Brush Assembly	(2)
	9	22-20-0692 Right Brush Holder	(1)
	10	23-52-0240 Brush Spring	(2)
	11	42-38-0181 Rubber Bumper	(2)
	13	23-66-2190 Switch	(1)
	14	06-55-0825 8-32 Hex Nut	(1)
	15	22-20-0691 Left Brush Holder	(1)
	16	31-15-0143 Cover	(1)
	17	06-82-7270 8-16 x 5/8" Plastite T-20 Screw	(3)
	18	06-82-0850 Ball Bearing	(1)
★	19	18-07-0037 120 V. Field	(1)
★	20	16-10-7090 120 V. Armature	(1)
	21	22-84-0680 Fan	(1)
★	22	06-82-7430 8-16 x 2-1/8" Plastite T-20 Screw	(2)
	23	02-08-0375 Ball Bearing	(1)
	24	06-65-0825 1/8 x 1/2 Groove Pin No. 5	(1)
	25	28-28-1670 Diaphragm	(1)
	26	02-08-0200 Ball Bearing	(1)
	27	32-40-1910 Intermediate Gear	(1)
	28	36-66-4350 Intermediate Pinion Shaft	(1)
	29	02-08-0200 Ball Bearing	(1)
	30	43-54-0520 Guard	(1)

FIG.	PART NO.	DESCRIPTION OF PART	NO. REQ.
	31	06-82-7252 8-32 x 3/8" Pan Hd. Slit. Taptite T-20	(2)
	32	34-60-0530 Retaining Ring	(1)
	33	32-30-0030 Drive Gear	(1)
	34	34-80-1505 Internal Retaining Ring	(1)
	35	02-04-1022 Ball Bearing	(1)
	36	06-42-0800 Woodruff Key	(1)
	37	43-16-0180 Eccentric Shaft	(1)
	38	02-04-0710 Ball Bearing	(1)
	39	28-14-1575 Gear Case	(1)
	40	06-82-7393 7-18 x 2" Plastite T-20 Screw	(4)
	41	44-94-0210 Connecting Rod	(1)
	42	02-50-2501 Needle Bearing	(1)
	43	06-65-1310 Dowel Pin	(1)
	44	38-50-5415 Spindle	(1)
	45	44-46-0200 Felt Oiler	(1)
	46	----- Top Shear Blade	(1)
	47	06-75-1985 8-32 x 5/16" Skt. Hd. Screw	(1)
	48	42-40-0395 Spindle Bushing	(1)
	49	----- Bottom Shear Blade	(1)
	50	30-99-0071 Yoke	(1)
	51	45-04-0680 Shoulder Screw	(1)
	52	06-75-2000 8-32 x 3/8" Skt. Hd. Screw	(1)
	53	06-83-1900 8-32 x 1/2" Skt. Hd. Set Screw	(1)
	54	48-44-0112 Shear Blade Kit	(1)
	55	23-16-1670 Commutator Insulator	(1)
		49-11-0080 Feeler Gauge	(1)
		49-96-0040 5/64" Socket Wrench	(1)
		49-96-0065 9/64" Socket Wrench	(1)

FIG. LUBRICATION
 39 3/4 Oz. Type "G" Grease, No. 49-08-4140.
 44/48 Coat Spindle with Type "G" Grease Before Assembly with Spindle Bushing.

MILWAUKEE ELECTRIC TOOL CORPORATION
 13135 W. LISBON RD., BROOKFIELD, WI 53005
 Drwg. 1