



# SERVICE PARTS LIST

**BULLETIN NO.**  
**54-08-7001**

SPECIFY CATALOG NO. AND SERIAL NO. WHEN ORDERING PARTS		REVISED BULLETIN 54-08-7000	DATE Mar. 2012
<b>CORDLESS D-HANDLE RAD</b>			
CATALOG NO. <b>0721-20</b>	STARTING SERIAL NO. <b>A73C</b>	WIRING INSTRUCTION <b>SEE REVERSE SIDE</b>	

00  
0

**EXAMPLE:**  
Component Parts (Small #)  
Are Included When Ordering  
The Assembly (Large #).

Concave side of connector  
block cover (29) to face  
connector block (24).

**TO SERVICE RIGHT  
ANGLE DRIVE UNIT  
CAT. NO. 48-06-2871  
(Fig. Nos. 12, 19, 40,  
41 and 43) REFER  
TO BULLETIN  
NO. 54-36-0602.**

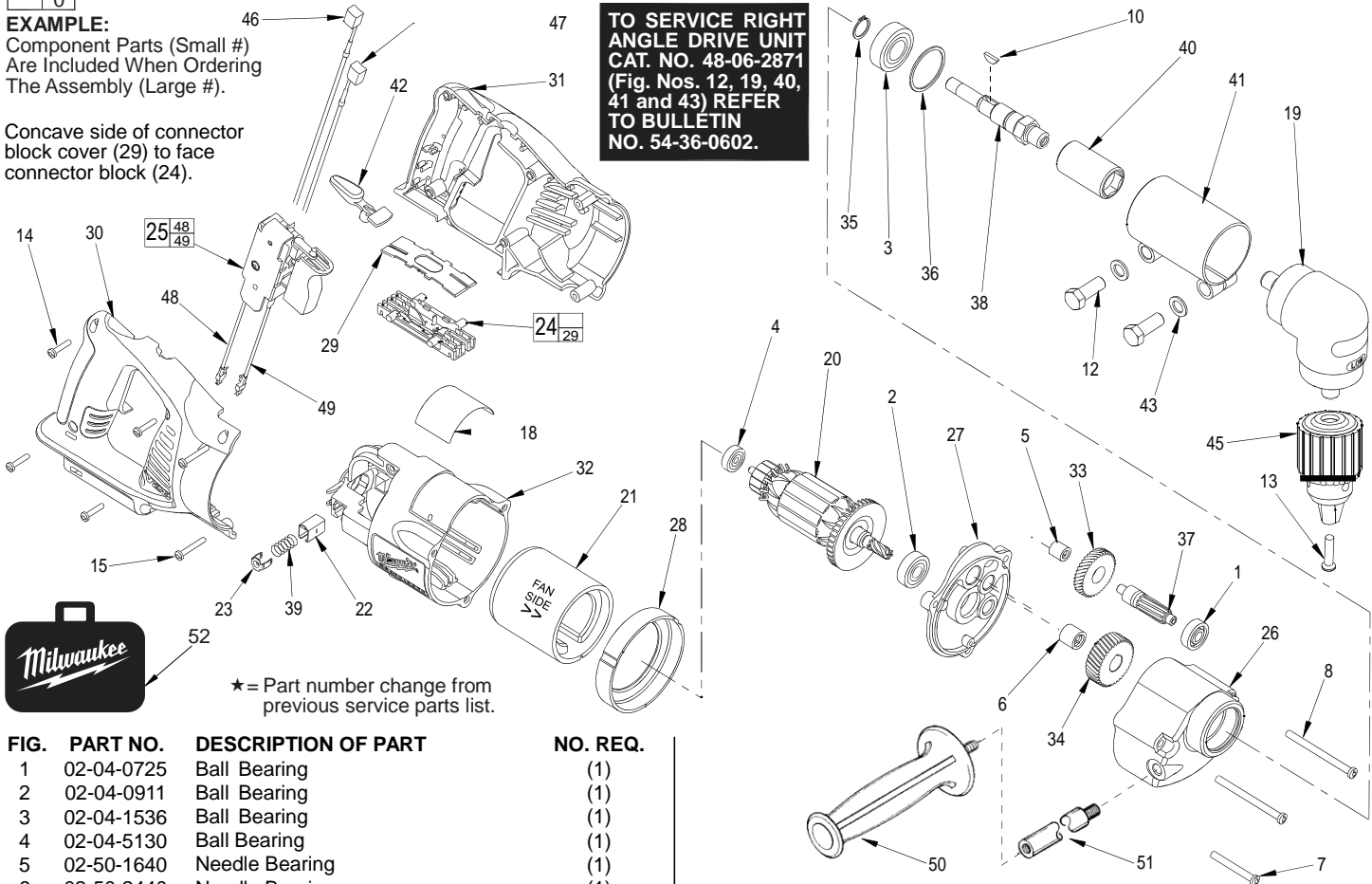

★ = Part number change from  
previous service parts list.

FIG.	PART NO.	DESCRIPTION OF PART	NO. REQ.
1	02-04-0725	Ball Bearing	(1)
2	02-04-0911	Ball Bearing	(1)
3	02-04-1536	Ball Bearing	(1)
4	02-04-5130	Ball Bearing	(1)
5	02-50-1640	Needle Bearing	(1)
6	02-50-2440	Needle Bearing	(1)
7	05-88-5905	K50 x 41mm Slit. Pan Hd. T-20 PT Screw	(1)
8	05-88-5927	K50 x 63mm Slit. Pan Hd. T-20 PT Screw	(2)
10	06-42-2000	Woodruff Key	(1)
12	06-75-0500	Hex Hd. Cap Screw	(2)
13	06-75-3150	1/4-20 x 1" L.H. Skt. Hd. Cap Screw	(1)
14	06-82-7261	6-19 x .687 Slotted Plastite T-15 Screw	(4)
15	06-82-7276	6-19 x 1.00 Slotted Plastite T-15 Screw	(2)
18	12-99-2120	Service Nameplate	(1)
19	14-72-0110	Right Angle Drive Assembly	(1)
20	16-01-0720	Armature Assembly	(1)
21	18-01-2120	Field Assembly	(1)
22	22-20-0860	Brush Tube	(2)
23	22-32-0400	Brush Spring Clip	(2)
24	22-56-0975	Connector Block Assembly	(1)
25	23-66-0023	Service Switch Assembly	(1)
26	28-14-1922	Gearcase	(1)
27	28-28-0601	Diaphragm	(1)
28	31-05-0719	Baffle	(1)
29	-----	Connector Block Cover	(1)
★30	31-44-2835	Right Handle Halve	(1)
★31	31-44-2840	Left Handle Halve	(1)
32	31-50-0019	Motor Housing	(1)
★33	32-40-1252	Intermediate Gear	(1)
34	32-75-2011	Spindle Gear	(1)
35	34-60-1200	External Retaining Ring	(1)
36	34-80-2500	Retaining Ring	(1)
★37	36-66-2712	Intermediate Pinion	(1)
38	38-50-5475	Spindle	(1)
39	40-50-8840	Brush Spring	(2)
40	42-90-0170	Reversible Female Coupling	(1)
41	45-22-0120	Attachment Sleeve Assembly	(1)
42	45-24-0720	Lock Off Lever	(1)

FIG.	PART NO.	DESCRIPTION OF PART	NO. REQ.
43	45-88-0601	Tool Retaining Washer	(1)
45	48-66-1360	1/2" Chuck	(1)
46	22-18-0719	Carbon Brush Assembly-Red	(1)
47	22-18-1719	Carbon Brush Assembly-Black	(1)
48	23-94-0016	Leadwire Assembly-Black	(1)
49	23-94-0015	Leadwire Assembly-Red	(1)
50	43-62-0885	Side Handle	(1)
51	43-62-1170	Side Handle Extension	(1)
52	48-55-0722	Carrying Case	(1)
	25-82-0130	Handle Ring (Not Shown)	(1)
	49-96-0070	5/32" Hex Key (Not Shown)	(1)
	49-96-4060	9/16" and 11/16" Wrench (Not Shown)	(1)
	48-66-3280	Chuck Key (Not Shown)	(1)

**LUBRICATION**

Place 3-3/4 oz. of type "A" grease, No. 49-08-0800, near ball bearing (1) in the gearcase (26).

**NOTES:**

Seal side of bearing (4) to face armature (20).

Stamped arrows (>>) on field casing (21) to face armature fan.

Needle bearings (5 and 6) are to be pressed from the open end flush to ±.005 to face of bearing boss of diaphragm (21).

Remove brush tubes (22) prior to removing armature assembly (20) from motor housing (32).

Install brush tubes (22) into motor housing (32) only after armature assembly (20) has been secured into motor housing (32).

**MILWAUKEE ELECTRIC TOOL CORPORATION**  
13135 W. LISBON RD., BROOKFIELD, WI 53005