



SERVICE PARTS LIST

BULLETIN NO.
54-08-1302

SPECIFY CATALOG NO. AND SERIAL NO. WHEN ORDERING PARTS		REVISED BULLETIN 54-08-1301	DATE Jan. 2013
1/2" REVERSING DRILL with Quik-Lok Cord			
CATALOG NO.	1007-1	STARTING SERIAL NO.	628F
		WIRING INSTRUCTION 58-01-0296	

00
0

EXAMPLE:
Component Parts (Small #)
Are Included When Ordering
The Assembly (Large#).

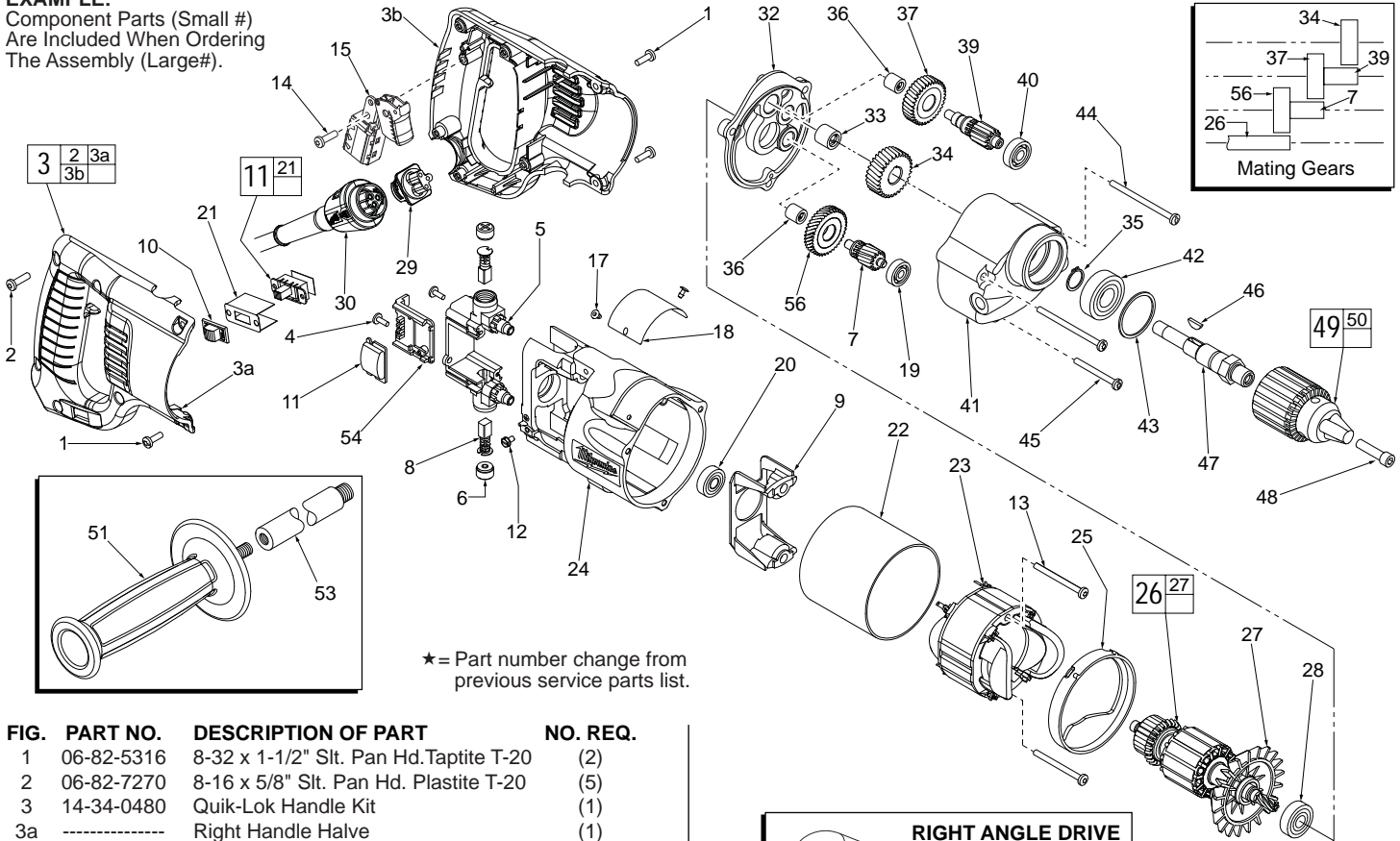

FIG.	PART NO.	DESCRIPTION OF PART	NO. REQ.
1	06-82-5316	8-32 x 1-1/2" Slit. Pan Hd. Taptite T-20	(2)
2	06-82-7270	8-16 x 5/8" Slit. Pan Hd. Plastite T-20	(5)
3	14-34-0480	Quik-Lok Handle Kit	(1)
3a	-----	Right Handle Halve	(1)
3b	-----	Left Handle Halve	(1)
4	06-95-0075	6-32 x 3/8" Truss Hd. Taptite	(2)
★ 5	22-22-1381	Brush Holder Assembly	(1)
6	23-44-0190	Brush Retaining Cap	(2)
★ 7	36-66-2812	Intermediate Shaft	(1)
8	22-18-0910	Carbon Brush Assembly	(2)
9	31-55-0190	Coil Shield	(1)
10	31-12-0196	Switch Cap	(1)
★ 11	14-20-0385	Remote Switch Assembly	(1)
12	06-95-5150	6-32 x 1/4" Hex Hd. Taptite Sems	(1)
★ 13	06-82-7380	7-18 x 1-7/8" Pan Hd. Taptite T-20	(2)
14	06-82-7270	8-16 x 5/8" Slit. Pan Hd. Plastite T-20	(1)
15	23-66-0205	Switch	(1)
17	06-72-1700	Nameplate Rivet	(2)
18	12-99-1750	Service Nameplate	(1)
19	02-04-0640	Ball Bearing	(1)
20	02-04-0845	Ball Bearing	(1)
21	-----	Paper Insulator	(1)
22	23-16-0456	Field Insulator	(1)
23	18-31-0600	120 Volt Field - Auto Assembly	(1)
★ 24	28-50-6222	Motor Housing	(1)
25	31-05-0055	Baffle	(1)
26	16-30-0226	120 Volt Armature	(1)
27	22-84-0531	Fan Assembly	(1)
28	02-04-0911	Ball Bearing	(1)
29	22-56-0815	Pin Housing Assembly	(1)
30	48-76-4008	Quik-Lok Cord Set	(1)
31	48-66-4040	Key Holder (Not Shown)	(1)
32	28-28-0611	Diaphragm	(1)
33	02-50-2440	Needle Bearing	(1)
34	32-75-2066	Spindle Gear	(1)
35	34-60-1200	Retaining Ring	(1)
36	02-50-1640	Needle Bearing	(2)
★ 37	32-75-2052	2nd Intermediate Gear	(1)

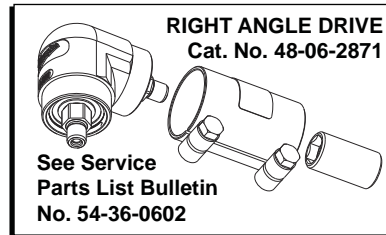

FIG.	PART NO.	DESCRIPTION OF PART	NO. REQ.
★ 39	36-66-4013	2nd Intermediate Shaft	(1)
40	02-04-0820	Ball Bearing	(1)
41	28-14-1922	Gear Case	(1)
42	02-04-1536	Ball Bearing	(1)
43	34-80-2500	Retaining Ring	(1)
44	06-82-5532	8-32 x 2-1/2" Slit. Pan Hd. Taptite T-20	(2)
45	06-82-5432	8-32 x 1-5/8" Slit. Pan Hd. Taptite T-20	(1)
46	06-42-2000	Woodruff Key	(1)
47	38-50-5475	Spindle	(1)
48	06-75-3150	1/4-20 x 1" L.H. Skt. Cap Screw	(1)
★ 49	48-66-1355	1/2" Chuck	(1)
50	48-66-3280	Chuck Key (Not Shown)	(1)
51	43-62-1265	Side Handle	(1)
53	43-62-1170	Side Handle Extension	(1)
54	43-72-0176	Heat Sink Holder	(1)
★ 56	32-40-1252	Intermediate Gear	(1)

FIG. LUBRICATION

41 3-3/4 Oz. Type "A" Grease, 49-08-0800.

FIG. NOTES:

51 Apply Red Loctite To Threads Of Side Handle.

MILWAUKEE ELECTRIC TOOL CORPORATION
13135 W. LISBON RD., BROOKFIELD, WI 53005