



SERVICE PARTS LIST

BULLETIN NO.
54-24-2421

SPECIFY CATALOG NO. AND SERIAL NO. WHEN ORDERING PARTS		REVISED BULLETIN 54-24-2420	DATE July 2013
Cordless M12 SDS Rotary Hammer			
CATALOG NO. 2412-20	STARTING SERIAL NO. E31B	WIRING INSTRUCTION SEE PAGE 4	

EXAMPLE:
00 0 Component Parts (Small #) Are Included
When Ordering The Assembly (Large #).

- = Component of the 14-46-2416 Service Maintenance Kit. See Page 2.
- ★ = Part number change from previous service parts list.

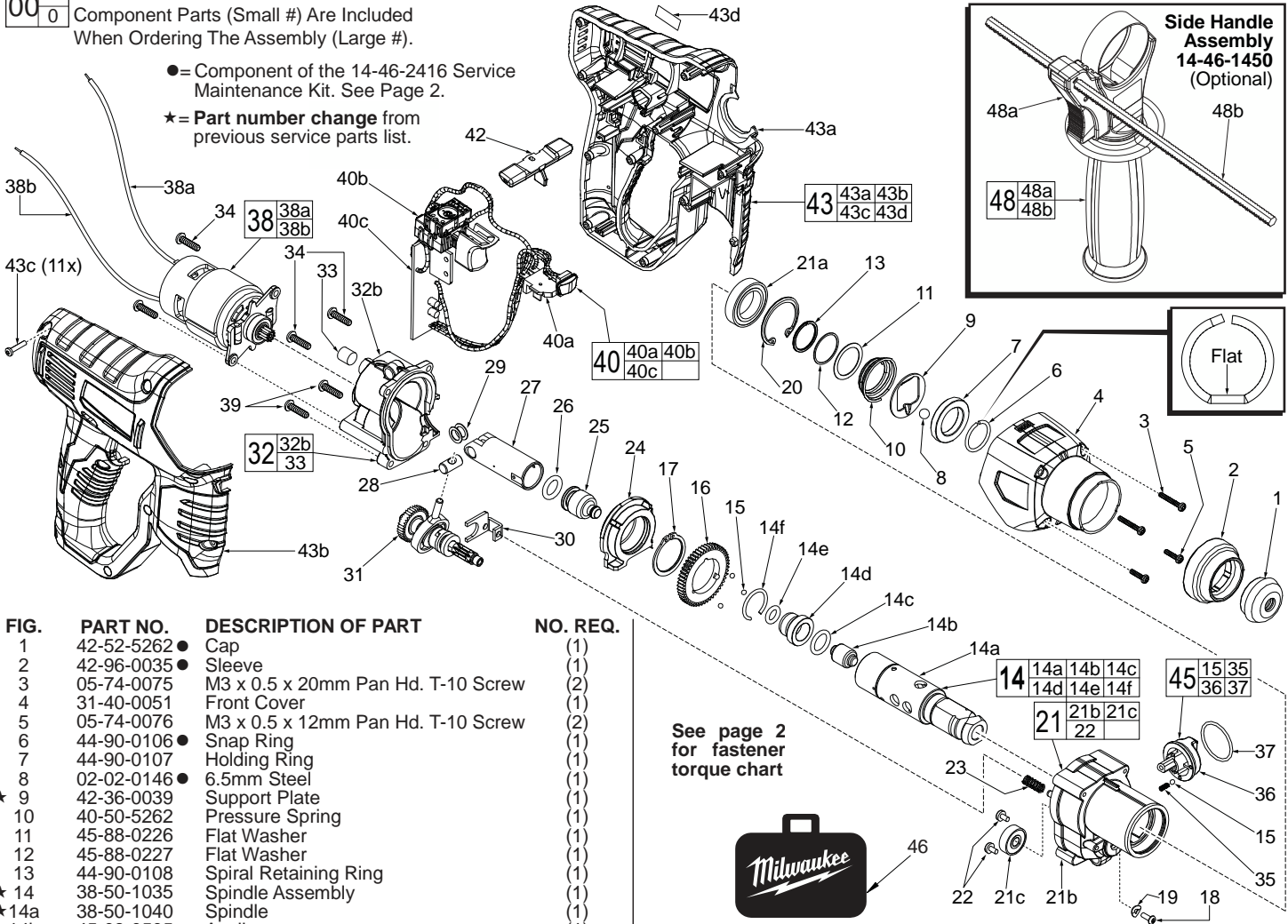

FIG.	PART NO.	DESCRIPTION OF PART	NO. REQ.
1	42-52-5262 ●	Cap	(1)
2	42-96-0035 ●	Sleeve	(1)
3	05-74-0075	M3 x 0.5 x 20mm Pan Hd. T-10 Screw	(2)
4	31-40-0051	Front Cover	(1)
5	05-74-0076	M3 x 0.5 x 12mm Pan Hd. T-10 Screw	(2)
6	44-90-0106 ●	Snap Ring	(1)
7	44-90-0107	Holding Ring	(1)
8	02-02-0146 ●	6.5mm Steel Support Plate	(1)
★ 9	42-36-0039	Pressure Spring	(1)
10	40-50-5262	Flat Washer	(1)
11	45-88-0226	Flat Washer	(1)
12	45-88-0227	Spiral Retaining Ring	(1)
13	44-90-0108	Spindle Assembly	(1)
★ 14	38-50-1035	Spindle	(1)
★ 14a	38-50-1040	Anvil	(1)
14b	45-08-0505	O-Ring	(1)
14c	34-40-0530 ●	Sleeve	(1)
14d	45-22-0008	O-Ring	(1)
14e	34-40-0531 ●	Snap Ring	(1)
14f	44-90-0109 ●	3.0 Steel Ball	(1)
15	02-02-1230 ●	2nd Stage Gear	(4)
16	32-44-1130	Retaining Ring	(1)
17	34-60-0140	Retaining Ring	(1)
★ 18	05-84-0005 ●	M3 x 0.5 x 8.5mm Pan Hd. T-10 Screw	(1)
★ 19	45-88-0107 ●	Wave Washer	(1)
20	34-80-0210	Retaining Ring	(1)
21	14-30-0065	Front Gearcase Assy. with Needle Bearing	(1)
21a	02-04-0315	Ball Bearing	(1)
21b	-----	Gearcase with Shift Pin	(1)
★ 21c	02-04-0325	Ball Bearing	(1)
22	05-81-0020	M3.0 x 5 Pan Hd. ST Screw	(2)
23	40-50-1215	Shifter Spring	(1)
24	28-72-0035	Bearing Holder Assy. with Needle Bearing	(1)
25	45-56-0025	Striker (Ram)	(1)
26	34-40-0532 ●	O-Ring	(1)
27	44-62-0145	Piston Wrist	(1)
28	44-60-0555	Pin Wrist	(1)
29	45-88-0228 ●	Washer	(2)
30	44-66-0405	Shifting Clip	(1)
★ 31	36-92-0300	Wobble Shaft Assembly	(1)
32	14-30-0070	Rear Gearcase Assy. with Needle Bearing	(1)
32b	-----	Rear Gearcase	(1)
33	43-84-0300 ●	Felt Plug	(1)
34	05-74-0010	M4 x 16 Screw	(4)
35	40-50-1220 ●	Spring	(1)
36	44-10-0605	Shift Knob	(1)
37	34-40-0533	O-Ring	(1)
38	14-50-0210	Motor Assembly	(1)
38a	-----	Black Leadwire Assembly	(1)

FIG.	PART NO.	DESCRIPTION OF PART	NO. REQ.
38b	----- ●	Red Leadwire Assembly	(1)
39	05-74-0012	M4 x 20 Screw	(2)
40	23-66-0820	Switch Assembly	(1)
40a	-----	Contact Plate Holder	(1)
40b	-----	Switch	(1)
40c	-----	PCB Assembly	(1)
42	42-42-0057	Forward / Reverse Shuttle	(1)
43	14-34-1010	Handle Housing Assy. with Fuel Gauge	(1)
43a	-----	Support Housing	(1)
43b	-----	Cover Housing	(1)
43c	06-82-7225	M3 x 12.5 Pan Hd. Plastite T-10 Screw	(11)
43d	10-20-0304	Fuel Gauge Label	(1)
44	12-20-2412	Service Nameplate (Not Shown)	(1)
45	44-10-0610	Shift Knob Assembly	(1)
46	42-55-2412	Carrying Case	(1)
47	10-20-1341	Warning Label (Not Shown)	(1)
48	14-46-1450	Side Handle Assembly (Optional)	(1)
48a	14-34-0650	Auxiliary Side Handle (Optional)	(1)
48b	44-94-5381	Depth Rod (Optional)	(1)

- FIG. NOTE:**
18 Apply a drop of Blue Loctite® 242 or the equivalent to the threads of screw prior to installing in front gearcase.
- 6,14a There is a 'flat' that is opposite the opening on the snap ring. Align 'flat' on snap ring with 'flat' on spindle.
- 8,9 Position ball notch on support plate and ball towards 'flats'.