



SERVICE PARTS LIST

BULLETIN NO.
54-06-2460

SPECIFY CATALOG NO. AND SERIAL NO. WHEN ORDERING PARTS		REVISED BULLETIN	DATE
M12™ CORDLESS CAULK and ADHESIVE GUN			Feb. 2014
CATALOG NO.	2441-20	SERIAL NUMBER	E34A
			WIRING INSTRUCTION SEE PAGE 5

FIG.	PART NO.	DESCRIPTION OF PART	NO. REQ.
1	34-80-0020	Retaining Ring	(1)
3	40-50-6420	Return Spring	(1)
4	45-98-0275	Clutch Yoke	(1)
5	-----	Slide Clutch	(1)
10	45-88-1940	Washer	(1)
11	32-40-2395	Input Gear	(1)
12	36-18-0610	Input Shaft	(1)
14	06-82-2025	M3.5 x 15 Pan Hd. Plastite T-10 Screw	(13)
24	45-24-0920	Shuttle Lock	(1)
25	28-20-2540	Left Cover	(1)
26	45-88-1945	Washer	(2)
27	34-80-0270	Retaining Ring	(1)
32	40-50-1475	Detent Spring	(1)
33	43-72-0430	Detent	(1)

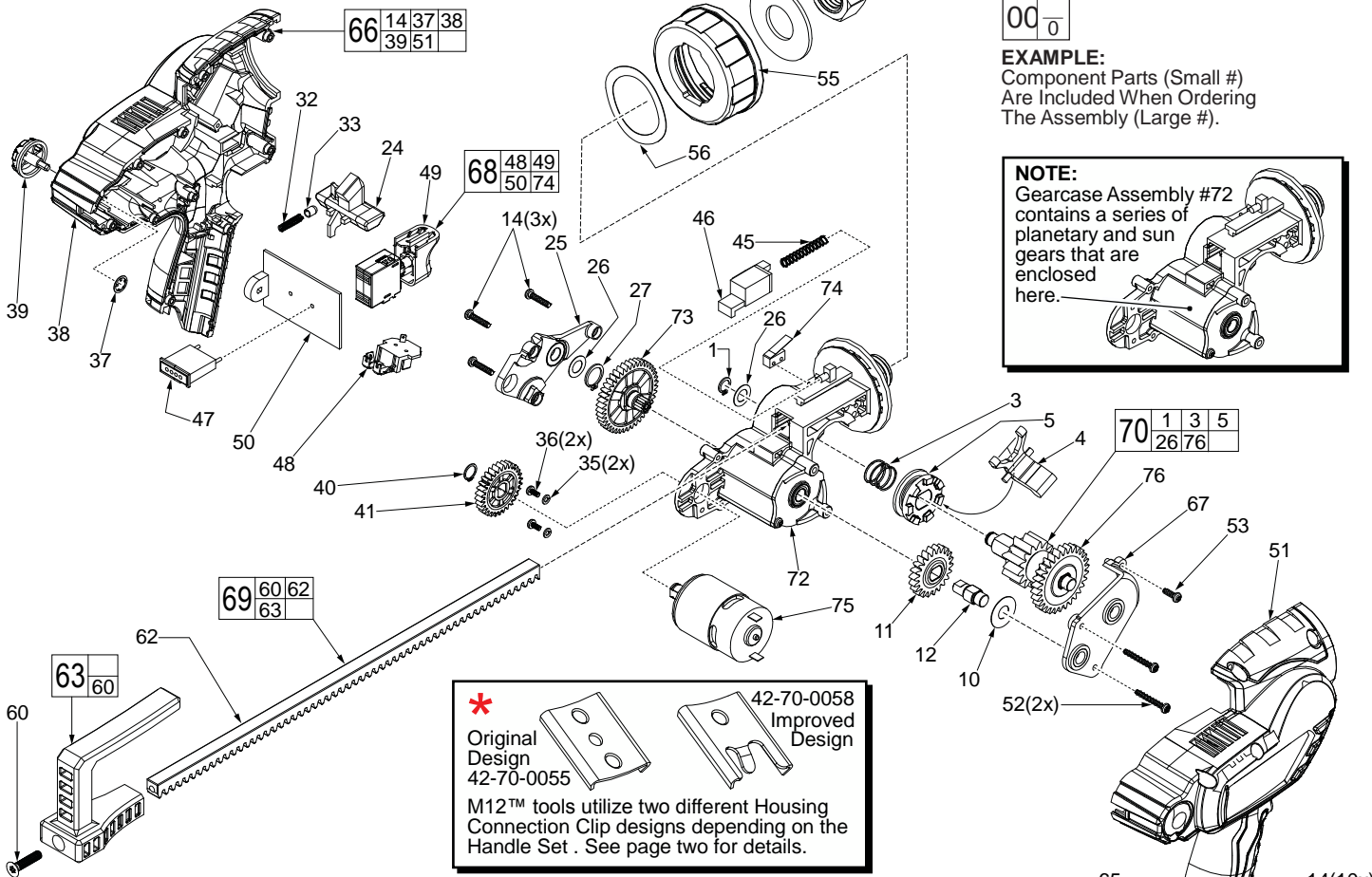

35	45-88-1980	Spring Washer	(2)
36	05-81-0205	M3 x 6 Pan Hd. Phillips Screw	(2)
37	42-70-1125	Clip	(1)
38	-----	Housing-Left	(1)
39	43-98-0570	Speed Dial	(1)
40	34-80-1120	Retaining Ring	(1)
41	32-40-0800	Input Gear	(1)
45	40-50-1635	Spring	(1)
46	23-38-0625	EOT Actuator	(1)
47	31-01-1725	Light Pipe with fuel gauge label	(1)
48	-----	Battery Contact Plate Assembly	(1)
49	-----	Switch	(1)
50	-----	PCB Assembly	(1)
51	-----	Housing-Right	(1)
52	05-88-0985	M3.5 x 26 Pan Hd. Phillips Screw	(2)
53	05-88-1610	M3.5 x 10 Pan Hd. T-10 Screw	(1)
55	42-52-0440	Cartridge Mounting Cap	(1)
56	45-88-2640	Wave Washer	(1)
57	45-88-1495	Flat Washer	(1)
58	06-55-0900	Hex Nut	(1)
59	44-70-0330	Plunger	(1)
60	45-04-2015	M5 x .8 Flat Hd. Phillips Screw	(2)
61	31-01-1910	10 Oz. Cartridge Holder	(1)

FIG.	PART NO.	DESCRIPTION OF PART	NO. REQ.
62	44-94-0490	10 Oz. Rack	(1)
63	31-44-3170	Rack Handle	(1)
65	42-70-0055	Housing Connection Clip	(1)
66	31-44-3175	Handle Assembly	(1)
67	28-20-0310	Right Cover Assembly	(1)
68	23-66-3135	Switch Assembly	(1)
69	44-94-0495	10 Oz. Rod Assembly	(1)
70	14-08-0240	Clutch Gear Assembly	(1)
72	14-30-0400	Gearcase Assembly	(1)
73	14-29-0725	Output Gear Assembly	(1)
74	-----	EOT Switch	(1)
75	23-30-0950	Motor Assembly with Drive Hub	(1)
76	-----	Output Gear Assembly	(1)
77	12-20-2441	Service Nameplate	(1)
78	10-20-3672	Warning Label	(1)

MILWAUKEE ELECTRIC TOOL CORPORATION
13135 W. LISBON RD., BROOKFIELD, WI 53005
Drwg. 4