



SERVICE PARTS LIST

BULLETIN NO.
54-26-2493

SPECIFY CATALOG NO. AND SERIAL NO. WHEN ORDERING PARTS		REVISED BULLETIN 54-26-2492	DATE Aug. 2014
M12 Brushless 3/8" Square Impact Driver			
CATALOG NO. 2454-20	STARTING SERIAL NO. E52D	WIRING INSTRUCTION SEE PAGES 2 and 3	

IMPORTANT NOTE: Gearcase end cap #25 is LEFT HAND THREAD!

As an aid to assembly, carefully lower the complete front end of tool (gearcase / impacting system) onto the gearcase end cap. Gently hand tighten front end assembly onto gearcase end cap. Be careful not to cross-thread! Once installed by hand, seat gearcase end cap with a good adjustable wrench using light pressure. Do not over tighten!

LEFT HAND THREAD

Torque to 260 in/lbs ±24 in/lbs (300 kgf-cm ±27 kgf-cm)

NOTE: Components of the impacting assembly (61) can drop out of the gearcase (57). Care must be taken to hold those elements in place when assembling onto the gearcase end cap (25).

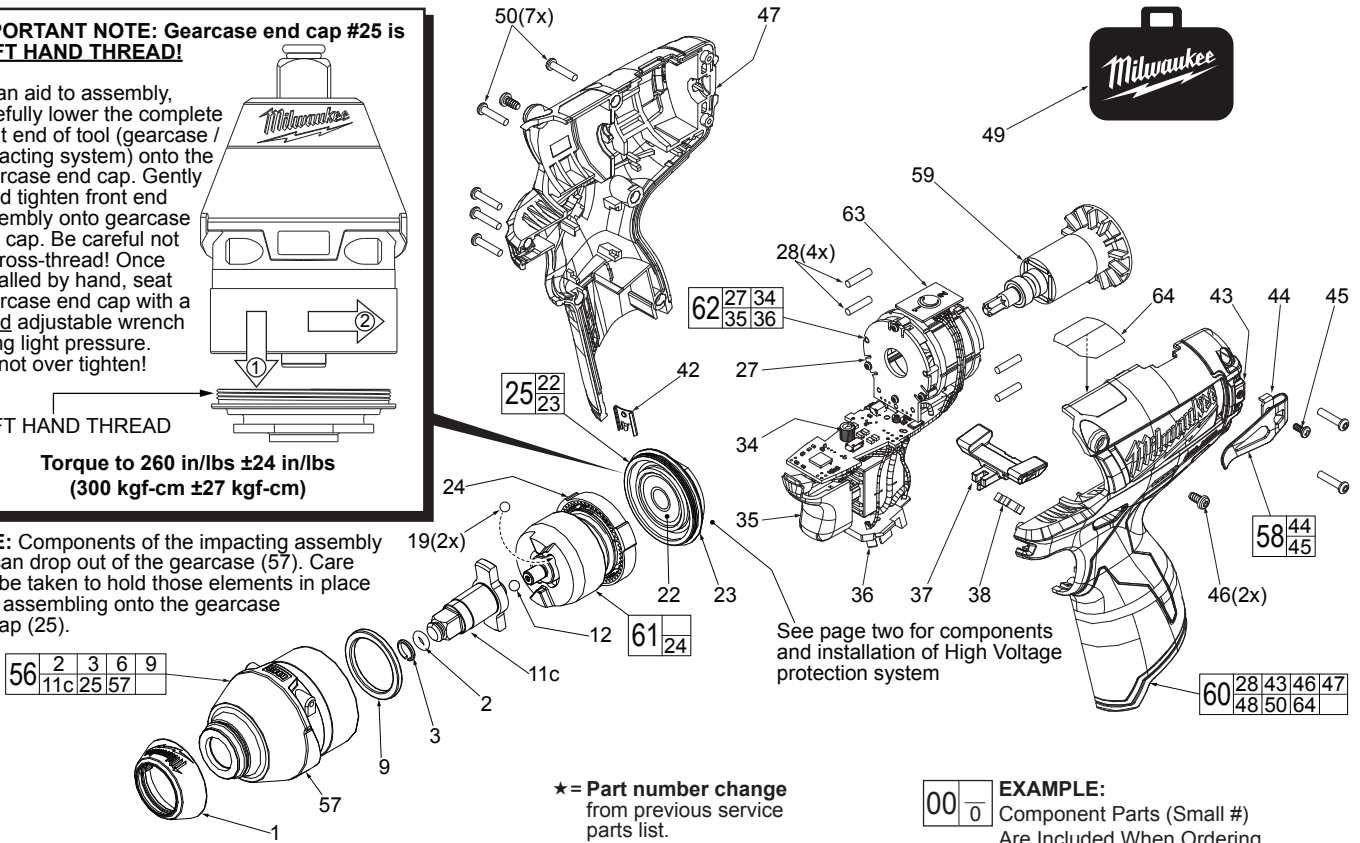

★ = Part number change from previous service parts list.

EXAMPLE:
00 0 Component Parts (Small #)
Are Included When Ordering
The Assembly (Large #).

FIG.	PART NO.	DESCRIPTION OF PART	NO. REQ.
1	31-12-0610	Rubber Cap	(1)
2	34-40-1885	3/8" O-Ring	(1)
3	44-90-1050	3/8" Friction Ring	(1)
6	-----	Anvil Bushing (Not Shown)	(1)
9	45-88-2135	Plastic Washer	(1)
11c	42-06-0225	3/8" Square Anvil	(1)
12	02-02-1300	5mm Steel Ball	(1)
19	02-02-0180	4.7mm Steel Ball	(2)
22	-----	Ball Bearing	(1)
23	-----	Gearcase End Cap	(1)
24	-----	Ring Gear	(1)
25	44-66-1065	Gearcase End Cap Assembly	(1)
27	-----	Stator Assembly	(1)
28	45-30-0300	Rubber Slug	(4)
34	-----	PCBA	(1)
35	-----	On-Off Switch	(1)
36	-----	Terminal Block Assembly	(1)
37	45-24-0810	Fwd/Rev Shuttle	(1)
38	40-50-1135	Spring	(1)
42	42-70-0058	Housing Clip	(1)
43	-----	Left Handle Halve with Fuel Gauge	(1)
44	42-70-0580	Belt Clip	(1)
45	-----	Belt Hook Screw	(1)
46	06-82-1090	M3 x 7mm Pan Hd. Plastite Screw	(2)
47	-----	Right Handle Halve	(1)
48	12-20-2435	Service Nameplate (Not Shown)	(1)
49	42-55-1060	Carrying Case	(1)

FIG.	PART NO.	DESCRIPTION OF PART	NO. REQ.
50	06-82-7236	4-20 x 5/8" Pan Hd. Plastite T-10 Scr	(7)
56	14-30-1190	Gearcase Assembly	(1)
57	28-50-0950	Front Gearcase with Bushing	(1)
58	42-70-0490	Belt Clip Assembly	(1)
59	16-07-0420	Rotor Assembly	(1)
60	31-44-2453	Handle Assembly	(1)
61	14-30-1220	Impacting Assembly	(1)
★62	14-20-1525	Electronics Assembly	(1)
63	23-66-2455	POP Switch	(1)
64	10-20-2845	Spanish/French Warning Label	(1)
70	23-94-2120	U-Shaped Stamping/Wire Kit (Page 2)	(1)

- FIG. LUBRICATION (Type 'J' Grease, No. 49-08-4220):**
- 11c Lightly coat front washer surface of anvil (11c) with grease.
 - 24,61 Lightly coat the I.D. of the ring gear (24) and the center of the planet gears of impacting assembly with grease.
 - 57 Coat inside of bushing inside front gearcase with grease.
 - 59 Coat pinion of rotor assembly (59) with grease.