



SERVICE PARTS LIST

BULLETIN NO.
54-26-2060

SPECIFY CATALOG NO. AND SERIAL NO. WHEN ORDERING PARTS		REVISED BULLETIN	DATE
M12™ Right Angle 1/4" Hex Impact Driver			July 2015
CATALOG NO.	2467-20	STARTING SERIAL NO.	G53A
		WIRING INSTRUCTION See Page 2	

EXAMPLE:
Component Parts (Small #)
Are Included When Ordering
The Assembly (Large #).

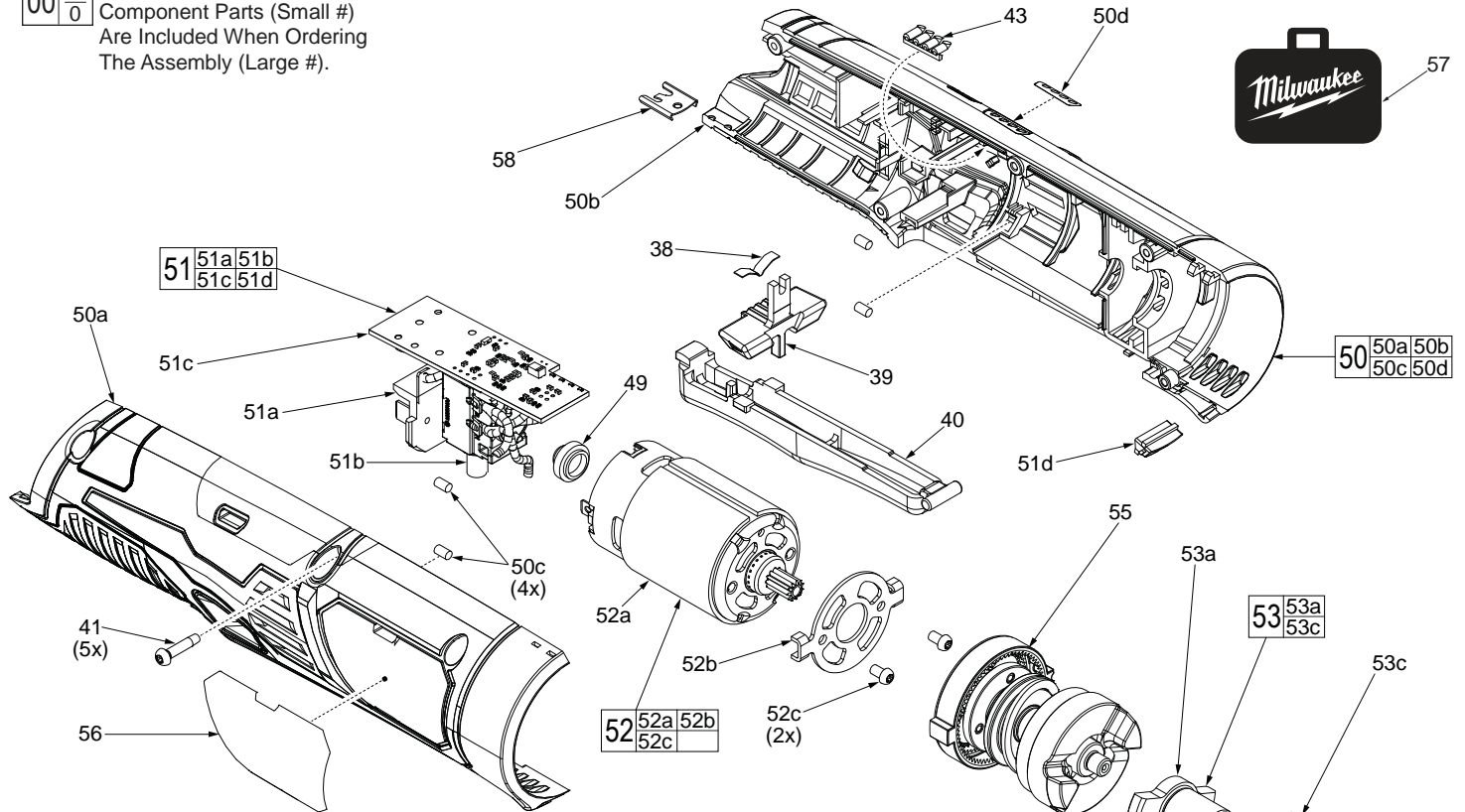

FIG.	PART NO.	DESCRIPTION OF PART	NO. REQ.
1	42-38-0500	Rubber Bumper Ring	1
2	44-90-0650	Retaining Ring	1
3	45-88-0428	Washer	1
4	40-50-0297	Spring	1
5	45-22-0880	Sleeve	1
9	02-02-7045	2.5mm Steel Ball	2
38	40-50-0027	Spring Plate	1
39	42-42-0084	Forward / Reverse Shuttle	1
40	31-92-0316	Trigger	1
41	06-82-1080	M13 x 14mm Pan Hd. Plast. T-10 Screw	5
43	44-06-0180	Fuel Gauge Lens	1
49	43-44-7062	Motor Brush Seal	1
50	31-44-2467	Housing Assembly	1
50a	-----	Housing Cover, Housing Halve-Right	1
50b	-----	Housing Support, Housing Halve-Left	1
50c	45-30-2653	Rubber Slug	4
50d	-----	Fuel Gauge Label	1
51	23-66-2467	Electronics Assembly	1
51a	-----	Battery Connector Block	1
51b	-----	On-Off Switch	1
51c	-----	PCBA	1
51d	-----	LED Assembly	1
52	23-30-1041	Motor Assembly with Pinion	1
52a	-----	Motor	1
52b	-----	Motor Mount Plate	1
52c	-----	Motor Mount Screw	2
53	42-06-1038	Anvil Assembly	1
53a	-----	Anvil	1
53c	-----	Nylon Washer	1
54	28-14-2467	1/4" Hex Gearcase Assembly	1
55	43-81-0201	Hammer Assembly	1
56	12-20-2469	Service Nameplate	1
57	42-55-2415	Contractor Bag	1
58	42-70-0058	Housing Connection Clip	1

