



SERVICE PARTS LIST

BULLETIN NO.
54-26-2501

SPECIFY CATALOG NO. AND SERIAL NO. WHEN ORDERING PARTS		REVISED BULLETIN	DATE
M18™ 1/4" Hex Impact Driver - Single Speed		54-26-2500	June 2016
CATALOG NO.	2656-20	WIRING INSTRUCTION	
STARTING SERIAL NO.	F26B	SEE PAGE 2	

EXAMPLE:
00 0 Component Parts (Small #)
Are Included When Ordering
The Assembly (Large #).

IMPORTANT NOTE: Gearcase end cap #24 is LEFT HAND THREAD!

As an aid to assembly, carefully lower the complete front end of tool (gearcase / impacting system) onto the gearcase end cap. Gently hand tighten front end assembly onto gearcase end cap. Be careful not to cross-thread! Once installed by hand, seat gearcase end cap with a good adjustable wrench using light pressure. Do not over tighten!

LEFT HAND THREAD

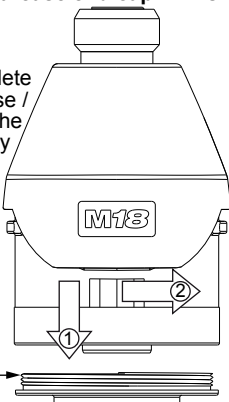

NOTE: Components of the impacting assembly (58) can drop out of the gearcase (54). Care must be taken to hold those elements in place when assembling onto the gearcase end cap (24).

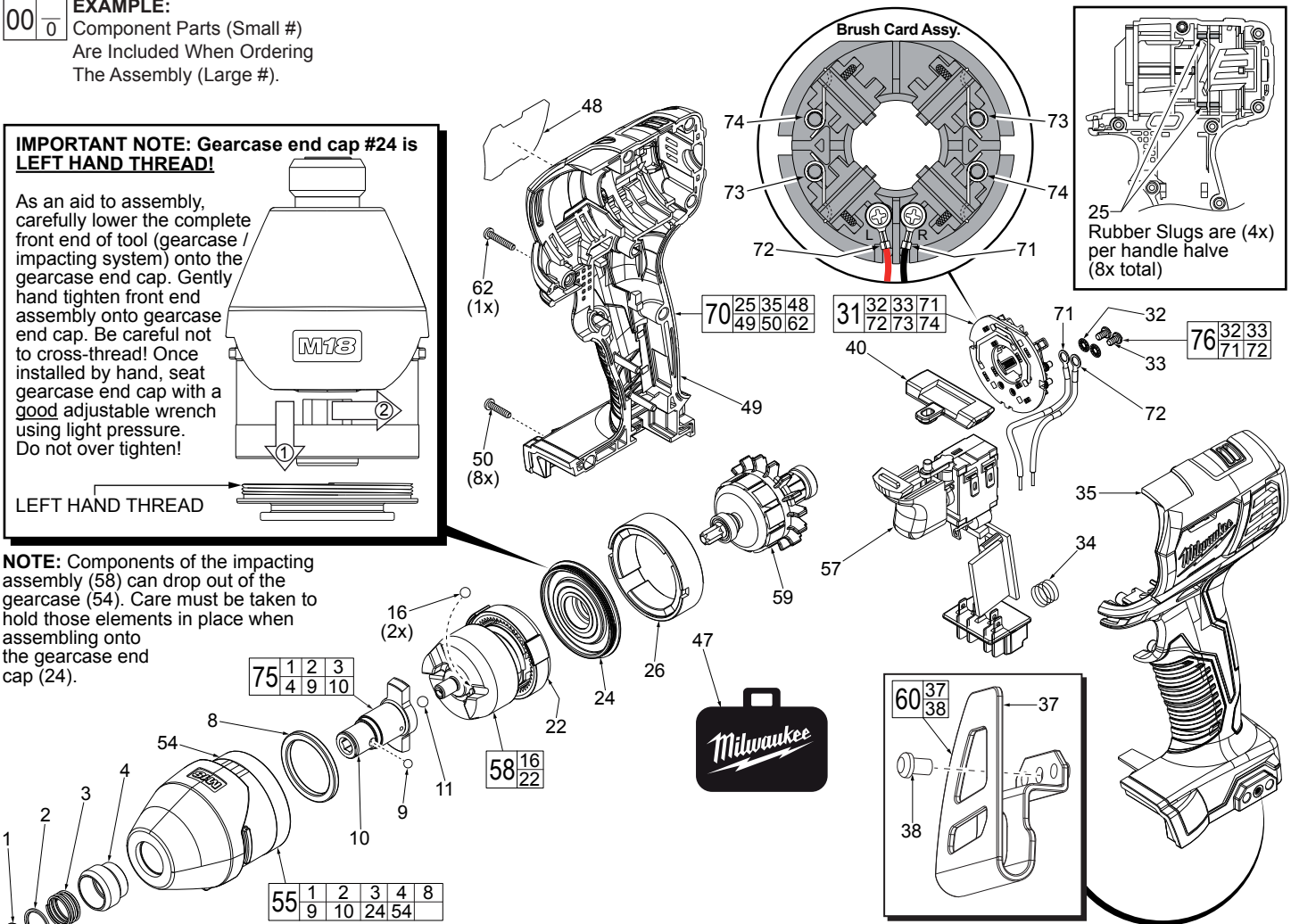

FIG.	PART NO.	DESCRIPTION OF PART	NO. REQ.
1	34-60-0725	Retaining Ring	1
2	45-88-1880	Washer	1
3	40-50-1470	Spring	1
4	45-22-2657	Sleeve	1
8	45-88-2653	Nylon Washer	1
9	02-02-1100	4.0mm Steel Ball	2
10	-----	1/4" Hex Anvil	1
11	02-02-1300	5.0mm Steel Ball	1
16	02-02-0180	4.7mm Steel Ball	2
22	-----	Ring Gear	1
24	44-66-0415	Gearcase End Cap with Ball Bearing	1
25	45-30-2653	Rubber Slug	8
26	18-01-2657	Field Assembly	1
31	22-22-2657	Brush Card Assembly	1
32	45-88-1980	Spring Washer	2
33	05-88-0926	M3 x 5mm Pan Hd. T-10 Screw	2
34	40-50-1090	Terminal Block Spring	1
35	-----	Handle Half - Left	1
37	-----	Belt Clip	1
38	06-82-0130	6-32 x 5/16" Pan Hd. T-15 Mach. Screw	1
40	45-24-2657	Forward/Reverse Shuttle	1
47	42-55-2657	Carrying Case	1
48	12-20-2618	Service Nameplate	1
49	-----	Handle Half - Right	1
50	06-82-7236	4-20 x 5/8" Pan Hd. Plastite T-10 Screw	8
54	28-50-2657	Gearcase with Bushing	1
55	14-30-2657	Gearcase Assembly	1
57	23-66-2659	Electronics Assembly - Single Speed Consists of: On-Off Switch, PCBA, LED and Battery Terminal Block	1

FIG.	PART NO.	DESCRIPTION OF PART	NO. REQ.
58	14-46-2657	Impacting Assembly	1
59	16-07-2657	Armature Assembly	1
60	42-70-2653	Belt Clip Assembly	1
62	06-82-7336	4-20 x 3/4" Pan Hd. Plastite T-10 Screw	1
70	31-44-2656	Handle Assembly - Single Speed	1
71	-----	Leadwire Assembly - Black - Right Side	1
72	-----	Leadwire Assembly - Red - Left Side	1
73	-----	Brush Spring - Right	2
74	-----	Brush Spring - Left	2
75	42-06-2657	1/4" Hex Anvil Assembly	1
76	14-46-2394	Leadwire/Screw/Washer Kit	1
77	10-20-1126	Warning Label (Not Shown)	1

- FIG. LUBRICATION**
(Type 'J' Grease, No. 49-08-4220):
- 10 Lightly coat front washer surface of anvil (10) with grease, place a dab in the ball holes of anvil.
 - 22,58 Lightly coat the I.D. of the ring gear (22) and the center of the planet gears of impacting assembly with grease.
 - 54 Coat inside of bushing inside front gearcase with grease.
 - 59 Coat pinion of armature assembly (59) with grease.