



SERVICE PARTS LIST

BULLETIN NO.
54-26-2671

SPECIFY CATALOG NO. AND SERIAL NO. WHEN ORDERING PARTS		REVISED BULLETIN 54-26-2670	DATE Nov. 2014
CORDLESS 18V 1/2" SQUARE IMPACT WRENCH			
CATALOG NO.	2663-20	STARTING SERIAL NO.	B80B
		WIRING INSTRUCTION See Page 3	

EXAMPLE:
Component Parts (Small #)
Are Included When Ordering
The Assembly (Large #).

★ = Part number change from previous service parts list.

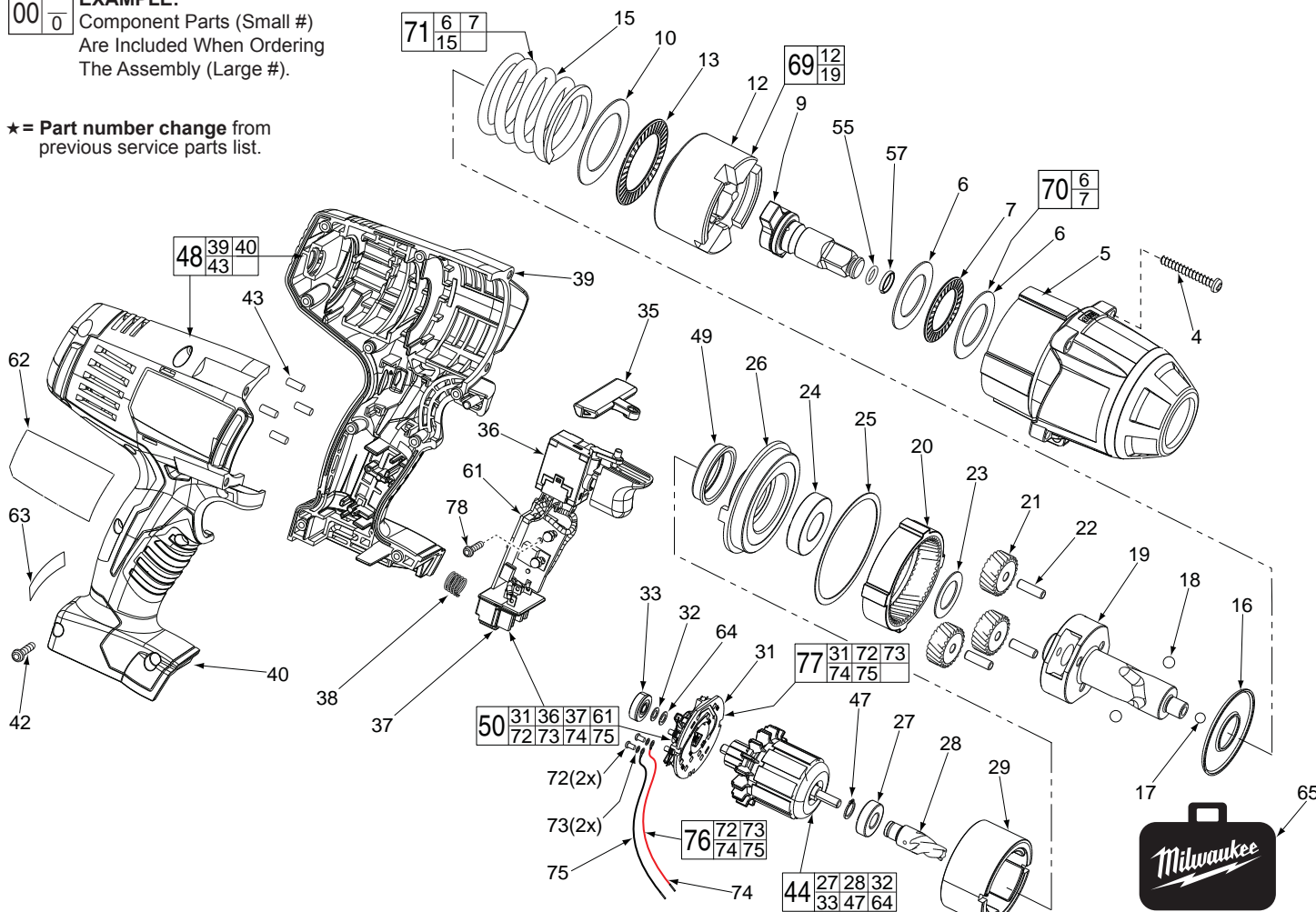

FIG.	PART NO.	DESCRIPTION OF PART	NO.REQ.
4	05-88-5988	M5 X 35mm Pan Hd. Slit. T-20 Screw	(4)
5	14-30-0870	Front Housing Assy. w/Bushing and O-Rings	(1)
6	-----	Washer	(2)
7	-----	Thrust Bearing	(1)
9	42-06-0680	1/2" Anvil	(1)
10	45-88-1006	Washer	(1)
12	-----	Hammer	(1)
13	02-80-0200	Thrust Bearing	(1)
15	-----	Compression Spring	(1)
16	45-88-1650	Washer	(1)
17	02-02-7010	7/32" Ball	(1)
18	02-02-0250	1/4" Ball	(2)
19	-----	Camshaft	(1)
20	32-65-0260	Ring Gear	(1)
21	32-62-0500	Planet Gear	(3)
22	44-60-1960	Pin	(3)
23	45-88-1655	Washer	(1)
24	02-04-0375	Ball Bearing	(1)
25	34-40-0290	Seal Ring	(1)
26	44-66-0895	Motor Mount Plate	(1)
27	-----	Ball Bearing - Front	(1)
28	-----	Pinion	(1)
29	18-01-3025	Service Field Assembly	(1)
31	-----	Brush Card	(1)
32	-----	Washer	(1)
33	-----	Ball Bearing - Rear	(1)
35	45-24-0570	Forward / Reverse Shuttle	(1)
36	-----	Switch	(1)
37	-----	Connector Block	(1)
38	40-50-1090	Compression Spring	(1)
39	-----	Handle - Left	(1)
40	-----	Handle - Right	(1)
42	06-82-0995	M4 x 16mm Pan Hd. T-20 Screw	(9)
43	45-30-0255	Rubber Slug	(4)
44	16-01-3030	Armature Assembly	(1)

FIG.	PART NO.	DESCRIPTION OF PART	NO.REQ.
47	-----	Retaining Ring	(1)
★48	31-44-0696	Handle Set	(1)
49	45-22-0380	Rubber Cap	(1)
★50	22-56-1451	Switch/Connector Block Assembly	(1)
55	34-40-0900	O-Ring	(1)
57	44-90-4530	C-Ring	(1)
61	-----	PCBA	(1)
62	12-20-2670	Service Nameplate Kit	(1)
63	10-20-2695	Warning Label	(1)
64	-----	Washer	(1)
65	42-55-2665	Carrying Case, Optional	(1)
69	14-46-2070	Camshaft/Hammer Service Kit	(1)
70	45-88-1877	Washer/Bearing Kit	(1)
71	14-46-0755	Spring/Washer/Bearing Kit	(1)
72	05-88-0928	M3 x 5mm Pan Hd. T10 Screw	(2)
73	45-88-1980	Spring Washer	(2)
74	-----	Leadwire Assembly - Red	(1)
75	-----	Leadwire Assembly - Black	(1)
76	14-46-2395	Leadwire/Screw/Washer Kit	(1)
77	14-46-2024	Brush Card Assembly	(1)
★78	06-82-2395	M2.6 x 10 Pan Hd. T-8 Screw	(1)

FIG. LUBRICATION
(Type 'Z' Grease, No. 49-08-7655):

20,21 Lightly coat the I.D. of the Ring Gear (20) and the center of the three Planet Gears (21) with grease.

19 Place a dab of grease in ball grooves of the Cam Shaft (19).

9 Lightly coat the front washer surface of Anvil (9) with grease, place a dab in the Ball hole on the backside of Anvil.

2 Coat outside grooves of Bushing (2) with grease.