



SERVICE PARTS LIST

BULLETIN NO.
54-24-2730

SPECIFY CATALOG NO. AND SERIAL NO. WHEN ORDERING PARTS		REVISED BULLETIN	DATE
M18™ Compact Brushless Hammer-Drill			Feb. 2015
CATALOG NO. 2702-20	STARTING SERIAL NO. G40A	WIRING INSTRUCTION SEE PAGE 2	

EXAMPLE:
00 0 Component Parts (Small #) Are Included
When Ordering The Assembly (Large #).

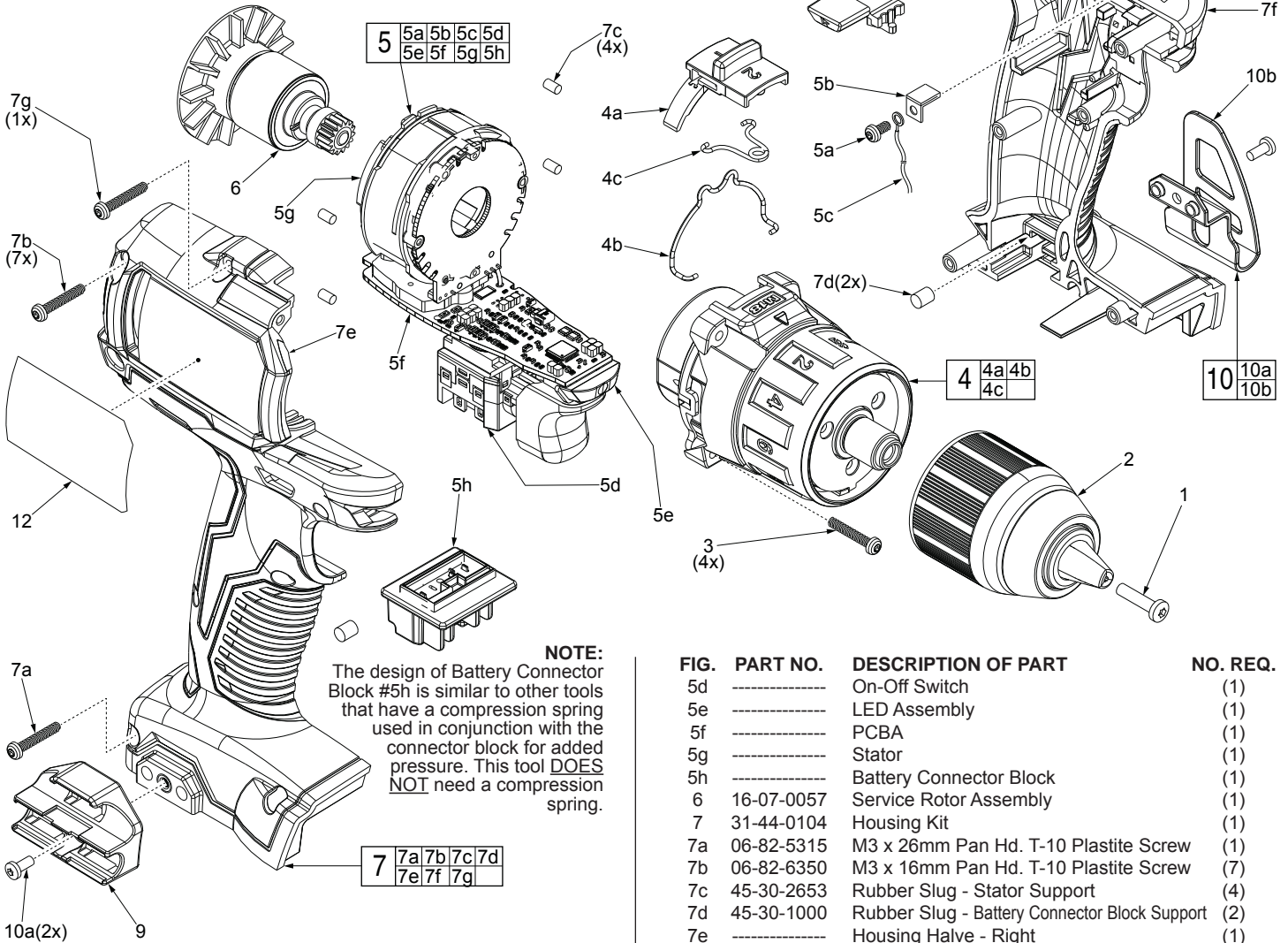

NOTE:
The design of Shuttle #8 is similar to other tools that have a spring plate used in conjunction with the shuttle. This tool **DOES NOT** need a spring plate.

NOTE:
The design of Battery Connector Block #5h is similar to other tools that have a compression spring used in conjunction with the connector block for added pressure. This tool **DOES NOT** need a compression spring.

FIG.	PART NO.	DESCRIPTION OF PART	NO. REQ.
1	05-88-1500	M6 x 27mm LH Chuck Screw	(1)
2	42-66-2702	1/2" Keyless Chuck	(1)
3	06-82-0135	M3 x 27mm Pan Hd. Plastite T-10 Screw	(4)
4	14-29-0052	Gearbox Assembly	(1)
4a	45-24-2607	Speed Selector Slide	(1)
4b	44-10-2607	Speed Change Lever	(1)
4c	40-50-2607	Torsion Spring	(1)
5	14-20-0037	Electronics Assembly Consisting of: On-Off Switch, PCBA, Stator, LED Assembly, Battery Connector Block and HV Contact Plate with Screw	(1)
5a	06-82-0062	M3 x 8mm Pan Hd. T-10 ST Screw	(1)
5b	40-50-0073	HV Contact Plate	(1)
5c	-----	HV Wire (Component of Battery Connector Block)	(1)

FIG.	PART NO.	DESCRIPTION OF PART	NO. REQ.
5d	-----	On-Off Switch	(1)
5e	-----	LED Assembly	(1)
5f	-----	PCBA	(1)
5g	-----	Stator	(1)
5h	-----	Battery Connector Block	(1)
6	16-07-0057	Service Rotor Assembly	(1)
7	31-44-0104	Housing Kit	(1)
7a	06-82-5315	M3 x 26mm Pan Hd. T-10 Plastite Screw	(1)
7b	06-82-6350	M3 x 16mm Pan Hd. T-10 Plastite Screw	(7)
7c	45-30-2653	Rubber Slug - Stator Support	(4)
7d	45-30-1000	Rubber Slug - Battery Connector Block Support	(2)
7e	-----	Housing Halve - Right	(1)
7f	-----	Housing Halve - Left	(1)
7g	06-82-0135	M3 x 18mm Pan Hd. Plastite T-10 Screw	(1)
8	42-42-0082	Forward/Reverse Shuttle	(1)
9	43-72-0550	Bit Holder Kit (Optional)	(1)
10	42-70-2653	Belt Clip Kit (Optional)	(1)
10a	06-82-0130	6-32 x 5/16" Pan Hd. T-15 Screw (Optional)	(2)
10b	-----	Belt Clip (Optional)	(1)
11	42-55-2701	Blow Molded Carrying Case	(1)
12	12-20-2701	Service Nameplate	(1)