



# SERVICE PARTS LIST

**BULLETIN NO.**  
**54-24-2740**

SPECIFY CATALOG NO. AND SERIAL NO. WHEN ORDERING PARTS		REVISED BULLETIN	DATE
<b>M18™ FUEL™ Hammer-Drill</b>			Nov. 2015
CATALOG NO. <b>2704-20</b>	STARTING SERIAL NO. <b>G73A</b>	WIRING INSTRUCTION <b>SEE PAGE 2</b>	

**EXAMPLE:**  

00	0
----	---

 Component Parts (Small #) Are Included When Ordering The Assembly (Large #).

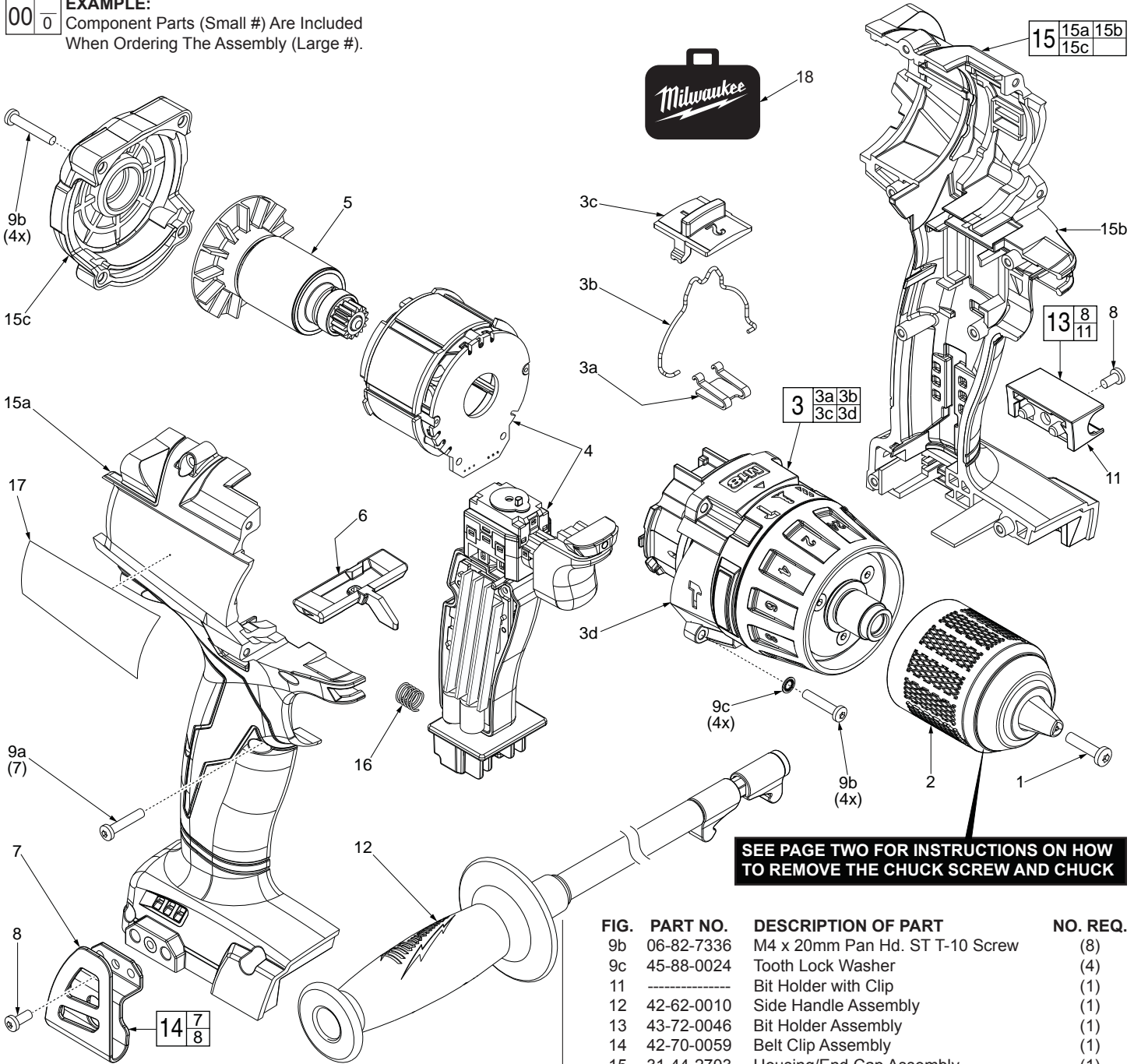

**SEE PAGE TWO FOR INSTRUCTIONS ON HOW TO REMOVE THE CHUCK SCREW AND CHUCK**

FIG.	PART NO.	DESCRIPTION OF PART	NO. REQ.
1	05-88-0019	M8.0 x 1 LH T-40 Chuck Screw	(1)
2	42-66-2706	1/2" Keyless Chuck with Carbide Jaws	(1)
3	14-29-0037	Gearbox Assembly	(1)
3a	40-50-0021	Detent Spring	(1)
3b	45-24-0012	Speed Change Lever	(1)
3c	44-10-0014	Speed Selector Slide	(1)
3d	-----	Gearbox	(1)
4	14-20-0032	Electronics Assembly Consists of: On-Off Switch, PCBA, Stator, LED Assembly, Battery Connector Block	(1)
5	16-07-0041	Rotor Assembly	(1)
6	42-42-0052	Forward/Reverse Shuttle	(1)
7	-----	Belt Clip	(1)
8	06-82-5275	6-32 x 5/16" Pan Hd. Taprite T-15 Screw	(2)
9a	06-82-6350	M3 x 16mm Pan Hd. ST T-10 Screw	(7)

FIG.	PART NO.	DESCRIPTION OF PART	NO. REQ.
9b	06-82-7336	M4 x 20mm Pan Hd. ST T-10 Screw	(8)
9c	45-88-0024	Tooth Lock Washer	(4)
11	-----	Bit Holder with Clip	(1)
12	42-62-0010	Side Handle Assembly	(1)
13	43-72-0046	Bit Holder Assembly	(1)
14	42-70-0059	Belt Clip Assembly	(1)
15	31-44-2703	Housing/End Cap Assembly	(1)
15a	-----	Right Housing Halve	(1)
15b	-----	Left Housing Halve	(1)
15c	-----	End Cap	(1)
16	40-50-1090	Compression Spring	(1)
17	12-20-0048	Service Nameplate	(1)
18	42-55-2703	Blow Molded Carrying Case	(1)