



SERVICE PARTS LIST

BULLETIN NO.
54-10-2720

SPECIFY CATALOG NO. AND SERIAL NO. WHEN ORDERING PARTS		REVISED BULLETIN	DATE
M18™ FUEL™ 1/2" Super-Hawg®			July 2015
CATALOG NO.	2709-20	STARTING SERIAL NO.	G60A
		WIRING INSTRUCTION SEE PAGE 4	

EXAMPLE:
00 ⁰/₀ Component Parts (Small #) Are Included
When Ordering The Assembly (Large #).

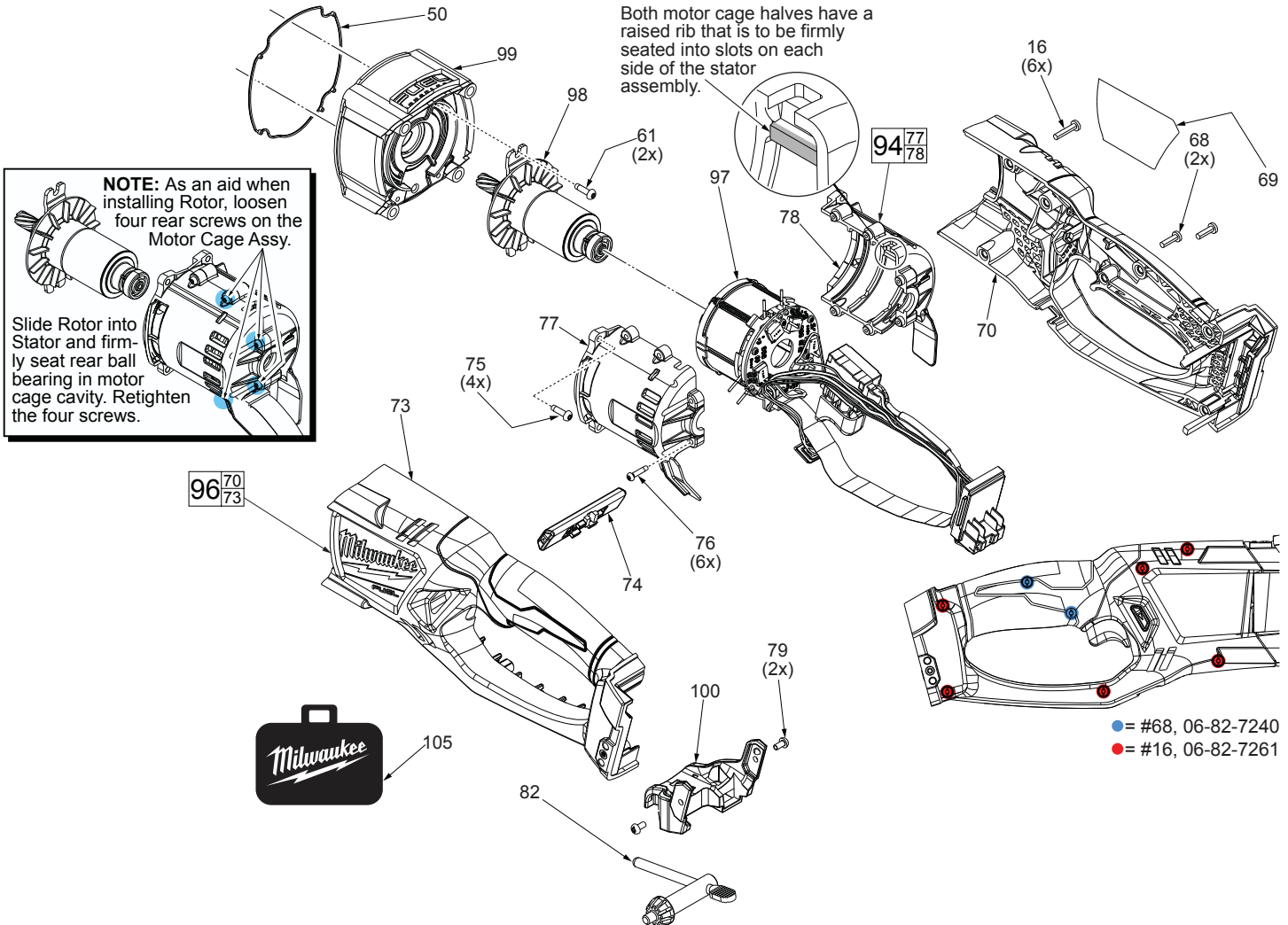

FIG.	PART NO.	DESCRIPTION OF PART	NO. REQ.
16	06-82-7261	6-19 x .687 Pan Hd. Slit. Plast. T-15 Screw	(6)
50	43-44-0705	Gasket	(1)
61	06-82-5314	10-24 x 1/2" Pan Hd. Tapt. T-25 Screw	(2)
68	06-82-7240	6-19 x .5 Pan Hd. Slit. Plast. T-15 Screw	(2)
69	12-20-0077	Service Nameplate	(1)
70	-----	Right Handle Halve (Cover)	(1)
72	45-30-1000	Rubber Slug	(2)
73	-----	Left Handle Halve (Support)	(1)
74	42-42-0017	Forward/Reverse Shuttle	(1)
75	06-82-5285	6-32 x .5 Pan Hd. Tapt. T-15 Screw	(4)
76	06-82-1080	M3 x 14mm T-10 ST Screw	(6)
77	-----	Motor Cage Cover - Left	(1)
78	-----	Motor Cage Support - Right	(1)
79	06-82-0130	6-32 x 5/16" Pan Hd. T-15 Machine Screw	(2)
82	48-66-3280	Chuck Key	(1)
94	23-16-0205	Motor Cage Assembly	(1)
96	31-44-1095	Handle Assembly	(1)
97	14-20-2709	Electronics Assembly Contains: Stator, PCBA, On-Off Switch, LED, Battery Connector Block	(1)
98	16-01-2709	Rotor Assembly	(1)
99	14-13-0055	Diaphragm Assembly with Needle Bearings	(1)
100	43-72-0077	Key Holder Assembly	(1)
105	42-55-3565	FUEL™ Contractor Bag - Large	(1)

IMPORTANT!
To prevent damage to the High Voltage Wire Assembly, a component in the Electronics Assembly #97, see service note on page 4 prior to removing the Motor Cage Cover #77.

SCREW TORQUE CHART			
Item	Part Number	Seat Torque (Kg./cm.) (In./lbs.)	
1	06-75-3155	140-160	122-139
4	06-82-5411	35-50	30-43
15	05-88-9915	60-65	52-56
16	06-82-7261	For Shift Hub	8-12 7-10
16	06-82-7261	For Handle	12-17 10-14
24	05-88-0510	30-45	26-39
30	06-82-5360	75-86	65-74
61	06-82-5314	46-58	40-50
68	06-82-7240	12-17	10-14
75	06-82-5285	12-17	10-14
76	06-82-1080	7-13	6-11
79	06-82-0130	10-15	8-13

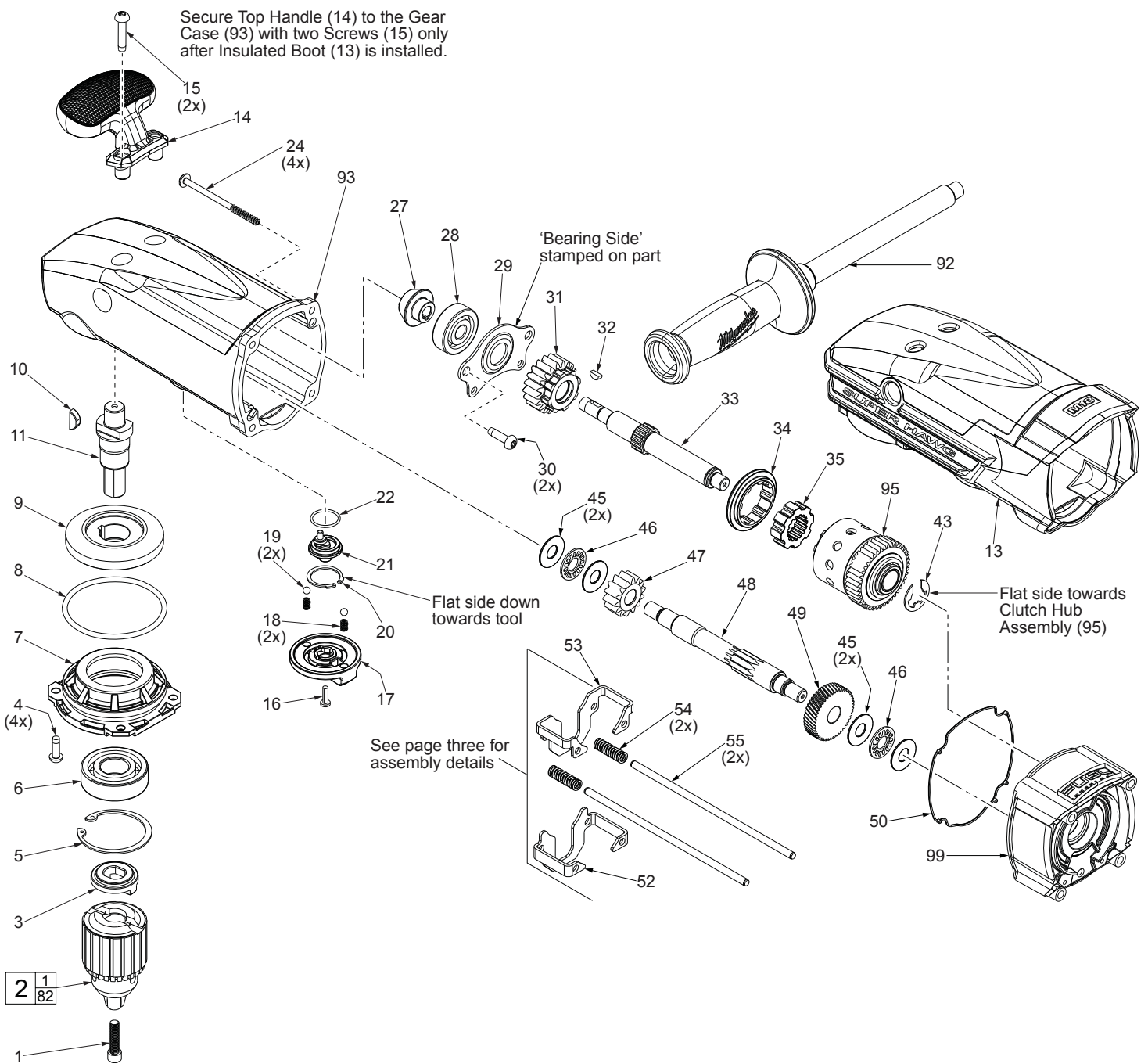

FIG.	PART NO.	DESCRIPTION OF PART	NO. REQ.
1	06-75-3155	1/4-20 x 1" Socket Head Screw-LH Thread	(1)
2	48-66-1481	1/2" Keyed Chuck with Chuck Key & Screw	(1)
3	28-53-0115	Chuck Hub	(1)
4	06-82-5411	10-24 x .625 Pan Hd. Taptite T-25 Screw	(4)
5	34-80-2980	Retaining Ring	(1)
6	02-04-2031	Ball Bearing	(1)
7	28-53-0095	Spindle Mounting Hub	(1)
8	34-40-0005	O-Ring	(1)
9	32-05-0400	Bevel Gear	(1)
10	06-42-2400	Woodruff Key	(1)
11	38-50-0027	Spindle	(1)
13	45-12-0044	Insulated Boot	(1)
14	31-44-2709	Top Handle	(1)
15	05-88-9915	M5 x 1.23 x 25mm Pan Hd. DG T-25 Screw	(2)
16	06-82-7261	6-19 x .687 Pan Hd. Slit. Plast. T-15 Screw	(1)
17	43-98-0067	Shifting Knob	(1)
18	40-50-8690	Detent Spring	(2)
19	02-02-1300	Steel Ball	(2)
20	44-86-0032	Retaining Ring	(1)
21	28-53-0085	Shifting Hub	(1)
22	34-40-1570	O-Ring	(1)
24	05-88-0510	M5 x 80mm Pan Hd. T-20 PT Screw	(4)
27	32-60-0280	Bevel Pinion	(1)
28	02-04-1055	Ball Bearing	(1)

FIG.	PART NO.	DESCRIPTION OF PART	NO. REQ.
29	44-66-1005	Bearing Retaining Plate	(1)
30	06-82-5360	1/4-20 x .625 Pan Hd. Taptite T-30 Screw	(2)
31	32-44-0500	2nd Intermediate Gear Assembly - High	(1)
32	06-42-0800	Woodruff Key	(1)
33	36-66-0300	2nd Intermediate Shaft	(1)
34	42-90-0015	Shifting Ring	(1)
35	43-12-0065	Drive Hub	(1)
43	34-60-1450	E-Ring	(1)
45	45-88-0395	Thrust Washer	(4)
46	02-80-0180	Thrust Bearing	(2)
47	32-60-0405	2nd Intermediate Pinion - High	(1)
48	32-60-0400	2nd Intermediate Shaft	(1)
49	32-42-0200	1st Intermediate Gear	(1)
50	43-44-0705	Gasket	(1)
52	42-76-0281	Short Shift	(1)
53	42-76-0271	Long Shift	(1)
54	40-50-0067	Shifter Spring	(2)
55	44-94-0012	Shifting Rod	(2)
92	14-34-0030	Side Handle Assembly	(1)
93	14-30-0505	Gearcase Assembly with Needle Bearings	(1)
95	14-08-2709	Clutch Hub Assembly	(1)
99	14-13-0055	Diaphragm Assembly with Needle Bearings	(1)