



SERVICE PARTS LIST

BULLETIN NO.
54-05-0040

SPECIFY CATALOG NO. AND SERIAL NO. WHEN ORDERING PARTS		REVISED BULLETIN	DATE
M18™ HammerVAC™ Dust Extractor			July 2014
CATALOG NO.	2712-DE	SERIAL NUMBER	G30A
			WIRING INSTRUCTION See Page 2

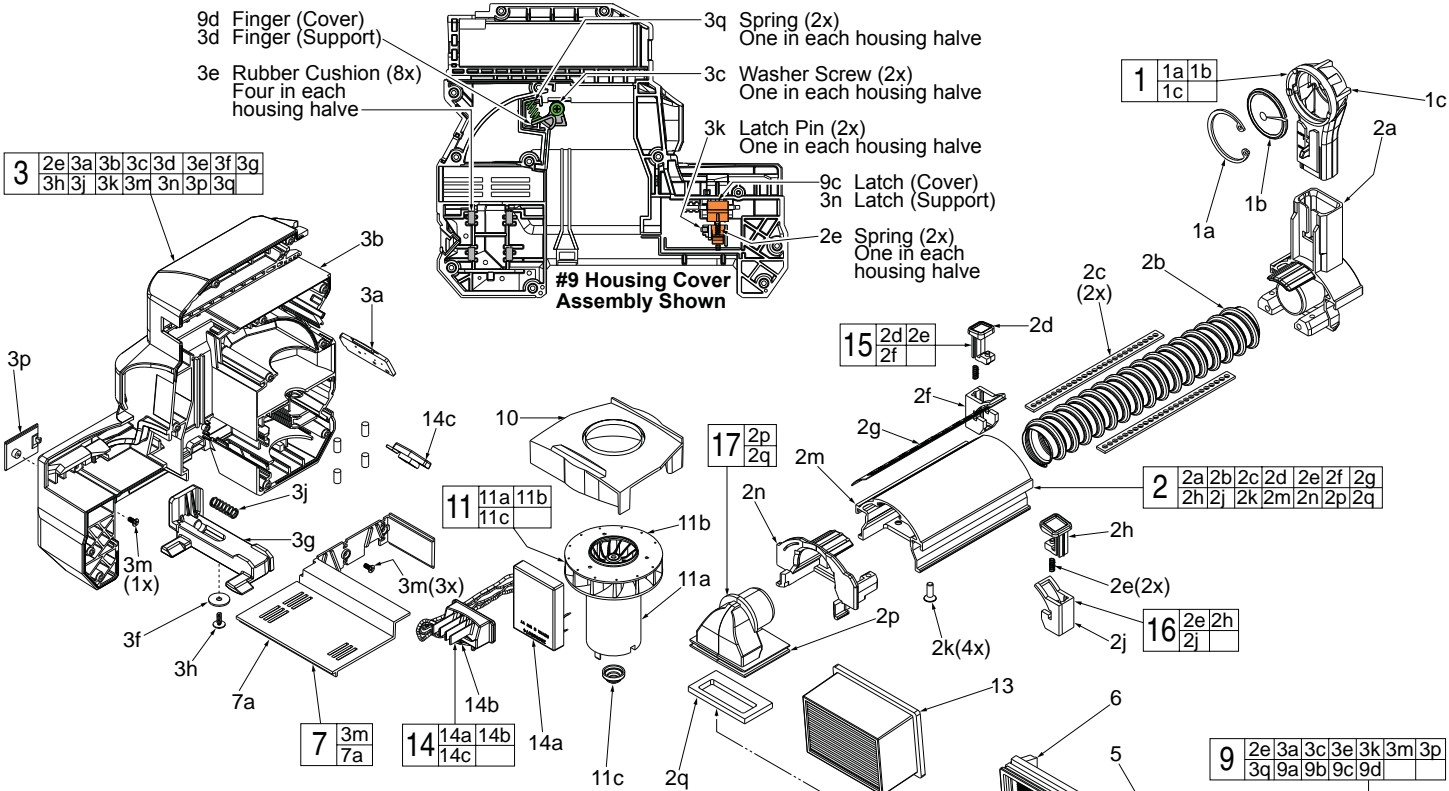

FIG.	PART NO.	DESCRIPTION OF PART	NO. REQ.
1	49-90-2301	Nozzle Top Assy. (Accessory, Pack of 2)	1
1a		Retaining Ring	1
1b		Hair Brush (Pack of 2)	1
1c		Nozzle Top	1
2	45-76-0067	AL Tube Assembly	1
2a	31-12-0082	Nozzle Base	1
2b	45-76-0022	Spring Tube	1
2c	44-81-0040	Detent Plate	2
2d		Depth Release Button	1
2e		Spring	2
2f		Depth Button Cover	1
2g	31-51-0155	Ruler	1
2h		Zero Release Button	1
2j		Zero Button Cover	1
2k	05-78-0135	Flat Hd. ST Phillips Screw	4
2m		AL Tube	1
2n	31-12-1000	Rear Tube Cap	1
2p		Dust Elbow	1
2q	43-44-0077	Gasket	1
3	14-38-0052	Housing Support Assembly	1
3a	43-84-2715	Housing Logo Insert	1
3b		Housing Support	1
3c		Screw	2
3d		Finger - Support Side	1
3e	45-30-0003	Rubber Cushion	8
3f	45-88-2160	Washer	1
3g	44-20-0044	Button for Latch	1
3h	05-88-0030	M3 x 8.5mm Pan Hd. ST T-10 Screw	1
3j	40-50-0127	Latch Button Spring	1
3k		Pin	2
3m	05-81-1100	M2.6 x 5mm Phillips Screw	5
3n		Latch	1
3p	42-92-0092	Latch Cover	2
3q		Spring	2
5	42-38-0047	Rubber Bumper	1
6	45-60-0135	Finger Support Plate	1
7	31-15-2715	Wire Cover Plate Assembly	1
7a		Wire Cover Plate	1
9	14-38-0059	Housing Cover Assembly	1
9a		Housing Cover	1
9b	06-82-1080	M3.0 x 14mm Pan Hd. T-10 ST Screw	11
9c		Latch	1
9d		Finger - Cover Side	1
10	31-76-0105	Fan Shroud	1

EXAMPLE:
Component Parts (Small #)
Are Included When Ordering
The Assembly (Large #).

FIG.	PART NO.	DESCRIPTION OF PART	NO. REQ.
11	14-50-2715	Motor/Fan Assembly	1
11a		Motor	1
11b		Fan	1
11c	43-44-1500	Rubber Cap Seal	1
12	49-90-2342	Dust Box (Accessory)	1
13	49-90-2306	Filter (Pack of 3)	1
14	14-20-2718	Electronics Assembly	1
14a		PCBA	1
14b		Terminal Block	1
14c		LED	1
15	42-42-0285	Depth Release Button Assembly	1
16	42-42-0295	Zero Release Button Assembly	1
17	31-05-2000	Dust Elbow Assembly	1
18	12-20-0055	Service Nameplate (See Page Two)	1
19	10-20-0498	Tri-Lingual Warning Label (See Page Two)	1
20	10-20-4352	Dust Box Label (See Page Two)	1
21	10-20-4349	M18 Label (See Page Two)	1