



SERVICE PARTS LIST

BULLETIN NO.
54-26-2752

SPECIFY CATALOG NO. AND SERIAL NO. WHEN ORDERING PARTS		REVISED BULLETIN	DATE
M18 FUEL™ 7/16" QUICK CONNECT IMPACT WRENCH		54-26-2751	Aug. 2016
CATALOG NO. 2765-20	STARTING SERIAL NO. F44C or F44D	WIRING INSTRUCTION See Page 2	

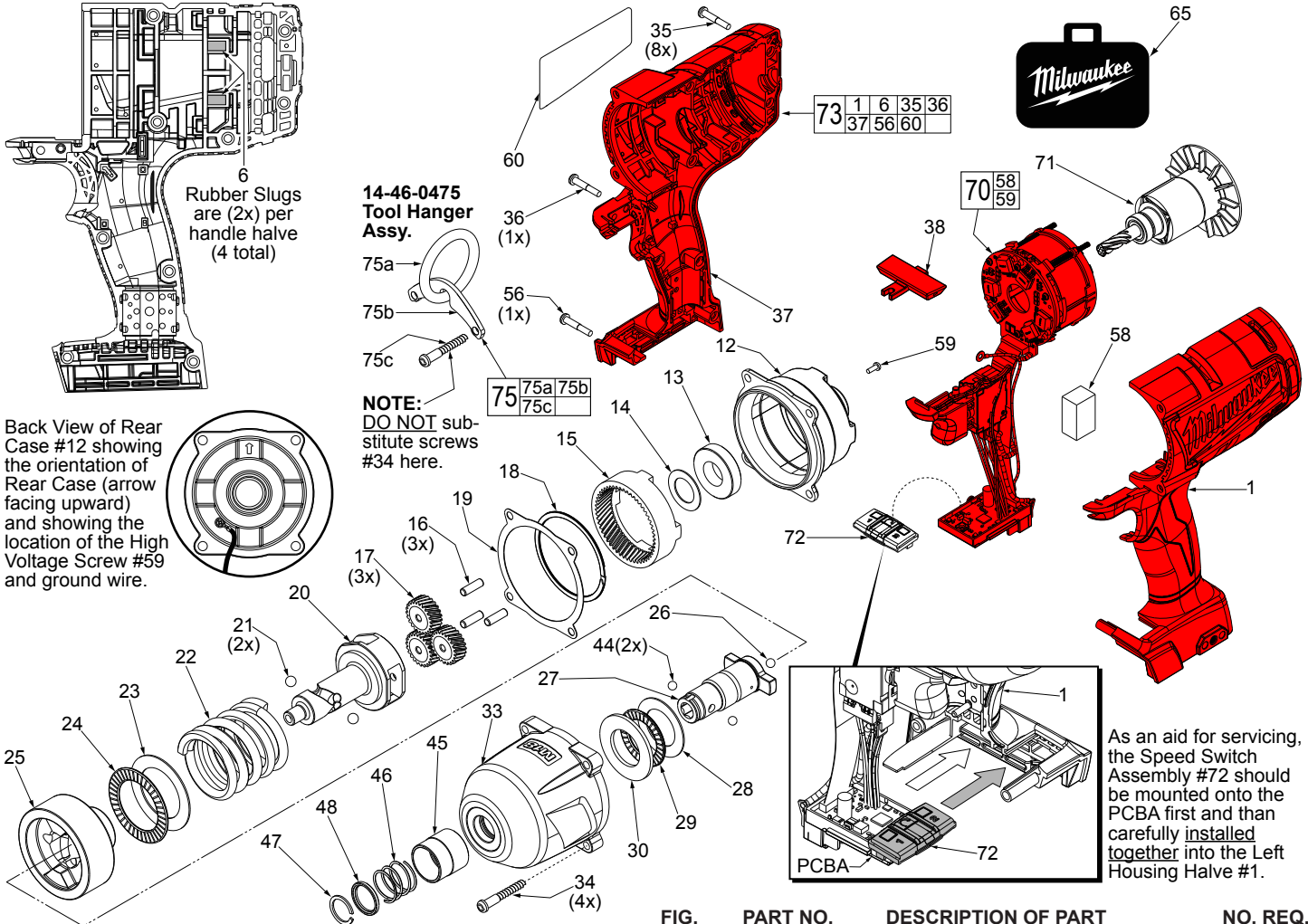

FIG.	PART NO.	DESCRIPTION OF PART	NO. REQ.
1	-----	Handle Support (Housing Halve-Left) w/ metal pin	1
6	45-30-0255	Rubber Slug	4
12	44-66-0417	Rear Case	1
13	02-04-0375	Ball Bearing	1
14	45-88-1655	Thrust Washer	1
15	32-65-0025	Ring Gear	1
16	44-60-1960	Planet Pin	3
17	32-62-0500	Planet Gear	3
18	30-40-0052	Retaining Ring	1
19	43-44-0065	Gasket	1
20	36-10-0020	Camshaft	1
21	02-02-0250	1/4" Steel Ball	2
22	40-50-0955	Hammer Spring	1
23	45-88-1006	Thrust Washer	1
24	02-80-0200	Hammer Thrust Bearing	1
25	43-81-0100	Hammer	1
26	02-02-7010	7/32" Steel Ball	1
27	42-06-0065	7/16" Hex Anvil	1
28	45-88-1875	Thrust Washer	1
29	02-80-3256	Thrust Bearing	1
30	45-88-1620	Thrust Washer	1
33	14-30-0120	Front Housing Assembly with Bushing	1
34	06-82-2210	50 x 40mm Pan Hd. PT T-20 Screw	4
35	06-82-0995	M4 x 16mm Pan Hd. Plastite T-20 Screw	8
36	06-82-2230	M4 x 22mm Pan Hd. Plastite T-20 Screw	1
37	-----	Handle Cover (Housing Halve Right)	1
39	40-50-0027	Shuttle Spring (for 45-24-0130, not shown)	1
44	02-02-0250	Steel Ball	2
45	42-76-0185	Sleeve	1
46	40-50-0365	Sleeve Spring	1
47	34-60-0050	Retaining Ring	1
48	44-90-0020	Washer	1
56	06-81-5383	M4 x 35mm Pan Hd. Plastite T-20 Screw	1
58	44-52-0025	Foam Pad	1

FIG.	PART NO.	DESCRIPTION OF PART	NO. REQ.
59	06-82-0165	High Voltage Screw	1
60	12-20-2626	Service Nameplate	1
65	48-55-3560	Contractor Bag	1
70	14-20-0093	Electronics Assembly	1
71	16-01-0105	Rotor Assembly	1
72	45-24-0110	Speed Switch Assembly	1
75	14-46-0475	Tool Hanger Assembly	1
75a	44-90-0095	Ring	1
75b	-----	Bracket	1
75c	-----	50 x 43mm Pan Hd. PT T-20 Screw	2

IMPORTANT! There are two different Electronic Assemblies available for servicing this tool. It is important to identify which Electronic Assembly is in your tool because the Housing Assembly and Fwd./Rev. Shuttle are UNIQUE to each switch design. To identify at a glance, one assembly is built with a switch that has a silver rivet on the side of the switch body, the other switch has none (see page two).

Electronic Assembly No. 14-20-0093 can be identified by a silver rivet on the side of the switch body, order the following parts:

FIG.	PART NO.	DESCRIPTION OF PART	NO. REQ.
38	45-24-0130	Forward / Reverse Shuttle	1
70	14-20-0093	Electronics Assembly (Switch with rivet)	1
73	31-44-0869	Housing Assembly	1

Electronic Assembly No. 14-20-0097 can be identified by the absence of a silver rivet on the side of switch body, order the following parts:

FIG.	PART NO.	DESCRIPTION OF PART	NO. REQ.
38	45-24-0022	Forward / Reverse Shuttle	1
70	14-20-0097	Electronics Assembly (Switch without rivet)	1
73	31-44-0879	Housing Assembly	1