



SERVICE PARTS LIST

BULLETIN NO.
54-42-0020

SPECIFY CATALOG NO. AND SERIAL NO. WHEN ORDERING PARTS		REVISED BULLETIN	DATE
M18™ FUEL™ DRYWALL SCREWDRIVER			Oct. 2016
CATALOG NO.	2866-20	STARTING SERIAL NO.	H47A
		WIRING INSTRUCTION See Page 2	

EXAMPLE:
Component Parts (Small #) Are Included
When Ordering The Assembly (Large #).

FIG.	PART NO.	DESCRIPTION OF PART	NO. REQ.
1	48-32-3065	Magnetic Bit Holder	(1)
8	02-80-0055	Thrust Bearing	(1)
17	40-50-0132	Bit Retaining Spring	(1)
18	02-02-0130	9/64" Steel Ball	(1)
20	45-88-0204	Thrust Bearing Washer	(1)
21	40-50-0142	Conical Spring	(1)

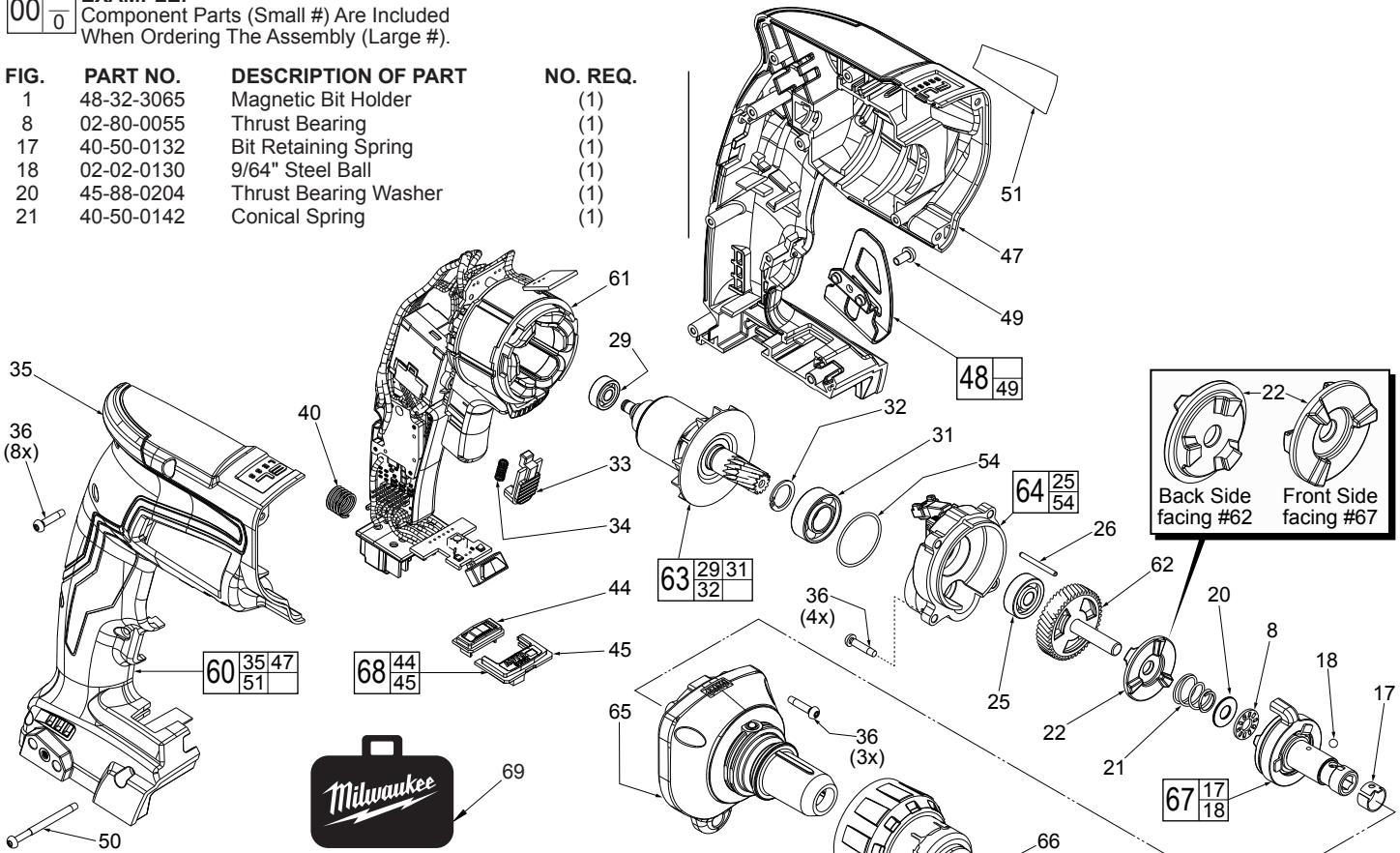

FIG.	PART NO.	DESCRIPTION OF PART	NO. REQ.
22	42-70-0222	Drive Clutch	(1)
25	02-04-0640	Ball Bearing	(1)
26	44-60-0412	Pin	(1)
28	-----	Screwdriver Bit	(1)
29	02-04-0033	Ball Bearing	(1)
31	02-04-0701	Ball Bearing	(1)
32	34-60-0575	Retaining Ring	(1)
33	31-15-0022	Lock-On Slide Lever	(1)
34	40-50-0422	Lock-On Spring	(1)
35	-----	Right Housing Halve-Housing Cover	(1)
36	06-82-1080	M3 x 14mm Pan Hd. ST T-10 Screw	(15)
40	40-50-1090	Terminal Block Spring	(1)
44	-----	Auto Start Button	(1)
45	-----	Auto Start Plate	(1)
47	-----	Left Housing Halve-Housing Support	(1)
48	42-70-0059	Belt Clip Kit	(1)
49	06-82-0130	6-32 x 5/16" Pan Hd. T-15 Mach. Scr.	(1)
50	06-82-0013	M3 x 38mm Pan Hd. ST T-10 Screw	(1)
51	12-20-0101	Service Nameplate	(1)
54	34-40-0076	O-Ring	(1)
60	31-44-1086	Housing Set	(1)
61	14-20-2866	Electronics Assembly Consisting of: Stator, Main PCBA, On-Off Switch, LED, Mode Selector PCBA and Battery Connector Block	(1)
62	32-10-0057	Clutch Gear Assembly	(1)
63	16-07-0212	Rotor Assembly	(1)
64	28-14-0711	Rear Gearcase Assembly	(1)
65	28-14-0712	Front Gearcase Assembly	(1)
66	49-26-1090	Nosecone Assembly	(1)
67	42-66-0025	Clutch Chuck Assembly	(1)
68	45-24-0305	Auto Start Assembly	(1)
69	42-55-2866	FUEL™ Small Contractor Bag	(1)
	10-20-1048	French/Spanish Warning Label (Not Shown)	(1)

LUBRICATION NOTE:

When servicing this tool, 90-95% of the old grease must be removed prior to new grease being added.

LUBRICATION

(Type "Y" Grease, No. 49-08-5270)

- Place a light coat of grease in the bottom inside cavity of rear gearcase (64) and over ball bearing (25). Use about .5 grams.
- Fill the 3 enlarged clutch pockets of the clutch gear assembly (62) with .5 grams grease. Install drive clutch (22).
- Add approximately 4.3 grams of grease into the rear gearcase, around the teeth of the armature pinion and the teeth of the clutch gear. Place a heavy coat of grease over the drive clutch (22).
- Coat with grease the thrust bearing (8), thrust bearing washer (20) and conical spring (21).
- Apply a light film of grease to the lead chamfer and barrel of the clutch chuck (67) prior to assembly into front gearcase (65).
- With clutch chuck (67) installed in the front gearcase (65), add approximately 3 grams of grease over the lugged surfaces of clutch chuck.