

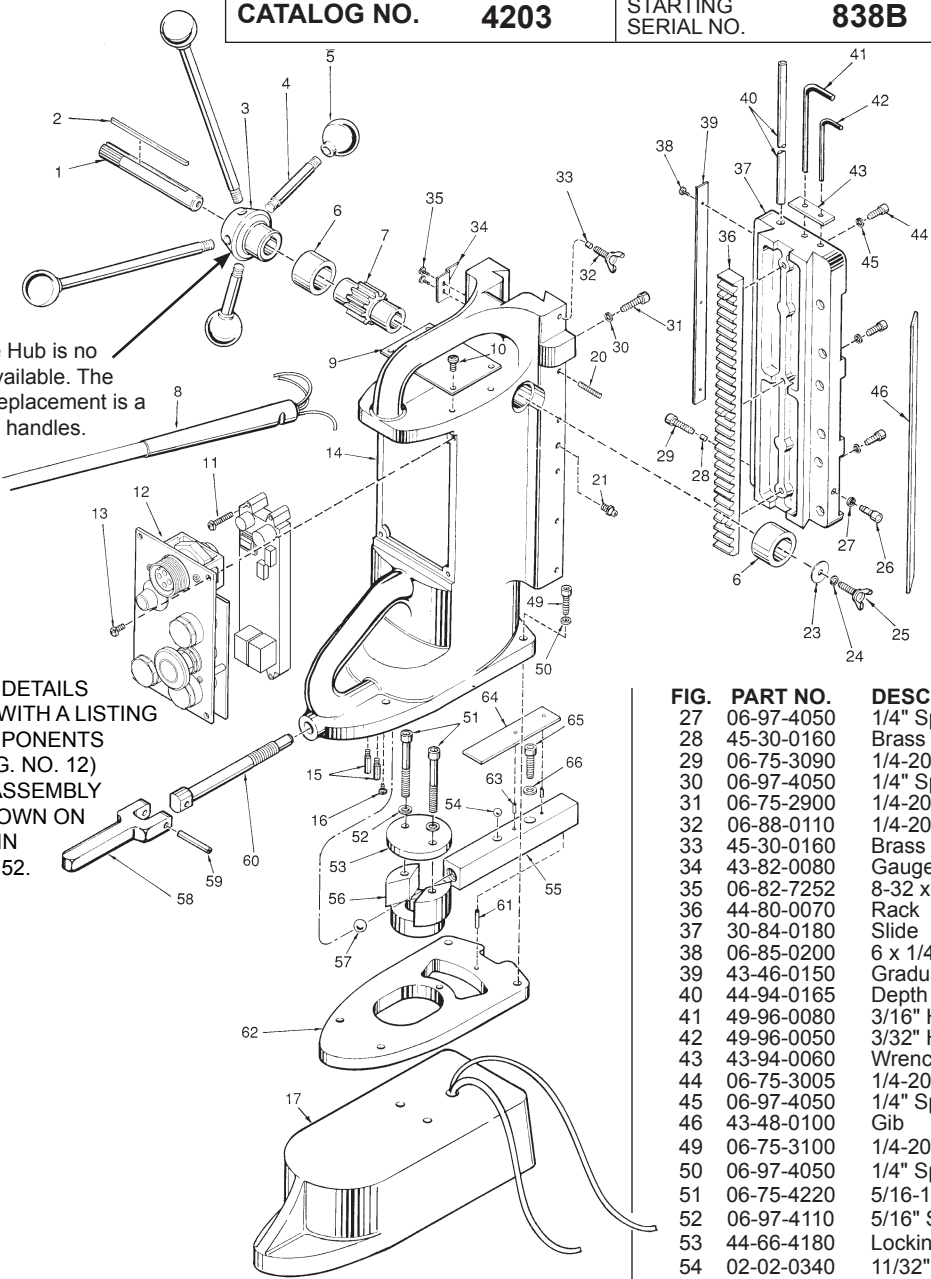

# SERVICE PARTS LIST

**BULLETIN NO.**  
**54-46-2251**

SPECIFY CATALOG NO. AND SERIAL NO. WHEN ORDERING PARTS		REVISED BULLETIN 54-46-2250	DATE Feb. 2008
<b>ELECTROMAGNETIC DRILL STAND</b>			
CATALOG NO.	<b>4203</b>	STARTING SERIAL NO.	<b>838B</b>
		WIRING INSTRUCTION <b>* SEE NOTE</b>	



**NOTE:**  
4 Handle Hub is no longer available. The service replacement is a hub for 3 handles.

**\* NOTE:**  
WIRING DETAILS ALONG WITH A LISTING OF COMPONENTS FOR (FIG. NO. 12) PANEL ASSEMBLY ARE SHOWN ON BULLETIN 54-30-0152.

**EXAMPLE:**  

00	0
----	---

 Component Parts (Small #) Are Included When Ordering The Assembly (Large #).

**NOTE:**  
THE INITIAL STAND DESIGN UTILIZED 10-32 X 1" SOCKET SET SCREWS (20) ALONG WITH LOCK NUTS. NEW SERVICE REPLACEMENT PART 06-83-2525 IS A 10-32 X 3/4" SOCKET SET SCREW AND HAS AN ADHESIVE PATCH ON THE THREADS. DISCARD OLD SOCKET SET SCREW AND LOCK NUT.

FIG.	PART NO.	DESCRIPTION OF PART	NO. REQ.
1	45-08-0160	Shaft	(1)
2	06-42-3750	1/8 x 3-1/2" Square Key	(1)
3	43-78-0260	Handle Hub	(1)
4	43-62-0055	Feed Handle	(4)
5	43-98-0050	Plastic Knob	(4)
6	42-40-0060	Bushing	(2)
7	32-60-2120	Pinion Gear	(1)
8	22-64-0076	Cord Set	(1)
9	12-99-1295	Service Nameplate	(1)
10	06-95-0075	6-32 x 3/8" Truss Hd. Taptite Screw	(4)
★ 11	06-82-2390	8-32 x 1-1/4" Taptite T-20	(3)
★ 12	-----	Panel Assembly (See Note)	(1)
13	06-82-7252	8-32 x 3/8" Pan Hd. Slit. Tapt. T-20	(4)
14	28-50-7830	Support Housing	(1)
15	45-04-0100	Cord Retaining Screw	(2)
16	06-81-8820	Ground Screw	(1)
★ 17	42-20-0825	Magnetic Base Assembly	(1)
★ 20	06-83-2525	10-32 x 3/4" Headless Socket Screw	(5)
21	43-33-0150	Grease Fitting	(2)
23	45-88-5247	Hub Washer	(1)
24	06-97-4050	1/4" Split Ring Lock Washer	(1)
25	06-88-0110	1/4-20 x 3/4" Wing Screw	(1)
26	06-75-2900	1/4-20 x 3/8" Socket Hd. Screw	(1)

FIG.	PART NO.	DESCRIPTION OF PART	NO. REQ.
27	06-97-4050	1/4" Split Ring Lock Washer	(1)
28	45-30-0160	Brass Slug	(2)
29	06-75-3090	1/4-20 x 7/8" Socket Hd. Screw	(2)
30	06-97-4050	1/4" Split Ring Lock Washer	(1)
31	06-75-2900	1/4-20 x 3/8" Socket Hd. Screw	(1)
32	06-88-0110	1/4-20 x 3/4" Wing Screw	(1)
33	45-30-0160	Brass Slug	(1)
34	43-82-0080	Gauge Indicator	(1)
35	06-82-7252	8-32 x 3/8" Pan Hd. Slit. Tapt. T-20	(2)
36	44-80-0070	Rack	(1)
37	30-84-0180	Slide	(1)
38	06-85-0200	6 x 1/4" Rd. Hd. Type Z Screw	(3)
39	43-46-0150	Graduated Gauge	(1)
40	44-94-0165	Depth Gauge Rod	(1)
41	49-96-0080	3/16" Hex Key	(1)
42	49-96-0050	3/32" Hex Key	(1)
43	43-94-0060	Wrench Keeper	(1)
44	06-75-3005	1/4-20 x 5/8" Socket Hd. Screw	(3)
45	06-97-4050	1/4" Split Ring Lock Washer	(3)
46	43-48-0100	Gib	(1)
49	06-75-3100	1/4-20 x 1" Socket Hd. Screw	(4)
50	06-97-4050	1/4" Split Ring Lock Washer	(4)
51	06-75-4220	5/16-18 X 2-1/2" Socket Hd. Screw	(2)
52	06-97-4110	5/16" Split Ring Lock Washer	(2)
53	44-66-4180	Locking Plate	(1)
54	02-02-0340	11/32" Steel Ball	(1)
55	44-20-0090	Adjusting Lock	(1)
56	45-52-2010	Adjusting Stop	(1)
57	02-02-0360	1/2" Steel Ball	(1)
58	43-62-0540	Locking Handle	(1)
59	06-65-1586	3/16" x 1-3/8" Roll Pin	(1)
60	42-32-0120	Locking Bolt	(1)
61	06-65-1534	1/8" x 5/8" Roll Pin	(1)
62	30-72-0050	Adjusting Plate	(1)
63	06-65-0575	3/32" x 5/16" Roll Pin	(2)
64	45-36-0800	Locking Spacer	(1)
65	06-75-3975	5/16-18 x 1" Socket Hd. Screw	(1)
66	06-97-4110	5/16" Split Ring Lock Washer	(1)
	48-58-0080	6' Safety Chain (Incl. 43-74-0080)	(1)
	43-74-0080	Chain Hook	(1)
	10-98-6095	Chain Label	(1)

**FOR MOUNTING DRILL MOTOR TO STAND USE:**  
 06-97-4050 1/4" Split Ring Lock Washer (4)  
 06-75-3050 1/4-20 x 3/4" Socket Hd. Screw (4)