

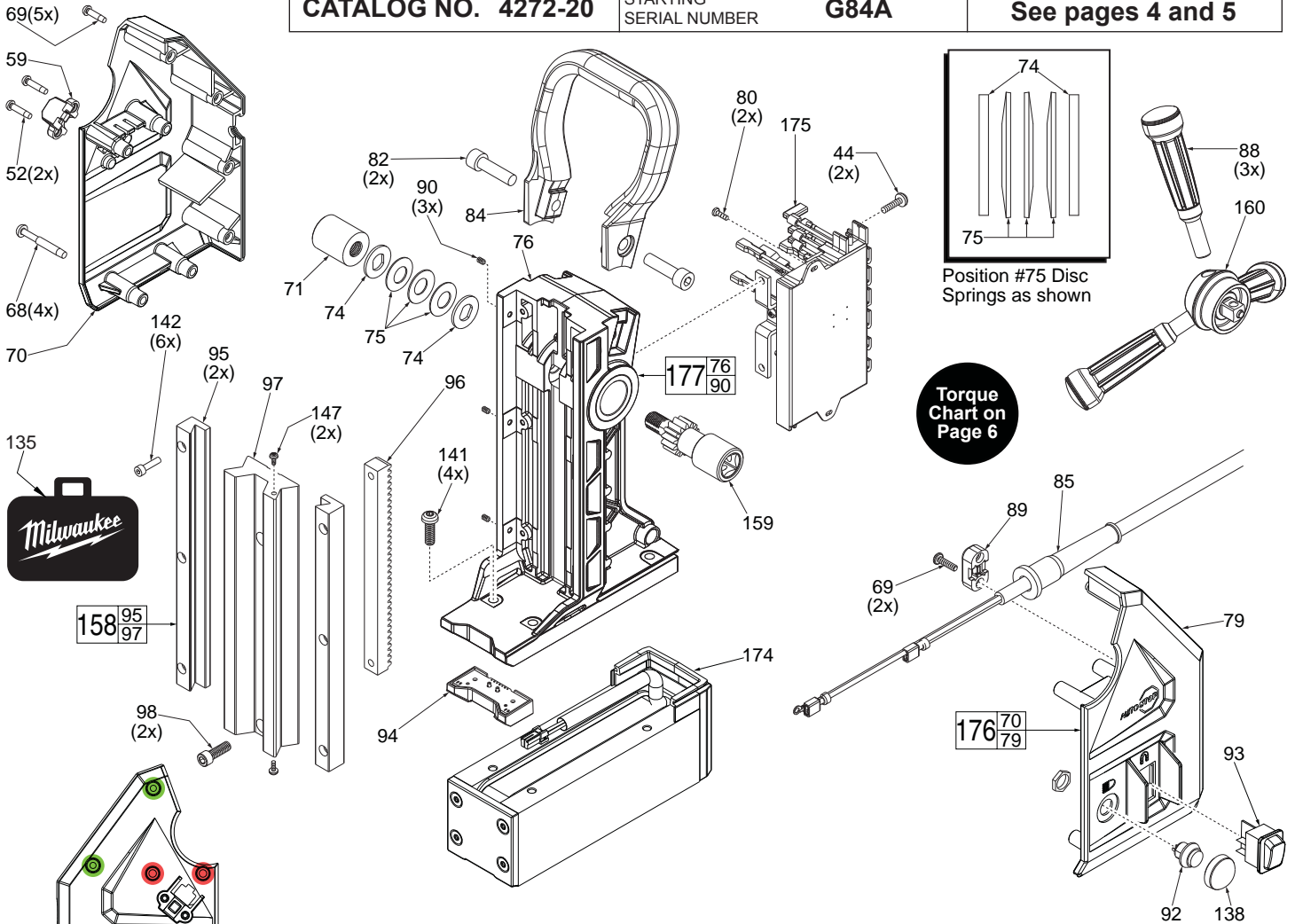

SERVICE PARTS LIST

BULLETIN NO.
54-46-0430

SPECIFY CATALOG NO. AND SERIAL NO. WHEN ORDERING PARTS		REVISED BULLETIN	DATE
120V Compact Magnetic Drill			Oct. 2015
CATALOG NO. 4272-20	STARTING SERIAL NUMBER	WIRING INSTRUCTION	
	G84A	See pages 4 and 5	



Torque Chart on Page 6

● = (68) 06-82-0009
● = (69) 06-82-0011

FIG.	PART NO.	DESCRIPTION OF PART	NO. REQ.
44	05-83-0020	M4 x 0.7 Pan Hd. Taptite Screw	(2)
52	05-88-1200	M4 x 16 Pan Hd. Plastite T-20 Screw	(2)
59	31-17-0080	Cord Clamp	(1)
68	06-82-0009	M5 Pan Hd. T-25 Screw	(4)
69	06-82-0011	M4 Pan Hd. T-20 Screw	(7)
70	-----	Housing Cover	(1)
71	43-12-0055	Handle Square Driver	(1)
74	45-88-0028	Washer	(2)
75	40-50-0029	Disc Spring	(3)
76	-----	Magstand Base with Bushings	(1)
79	-----	Housing Support	(1)
80	05-81-1290	M2.3 x 0.4-6g Washer Hd. T-8 Screw	(2)
82	05-74-0014	M8 x 1.125, 6mm Hex Socket Hd. Cap Scr.	(2)
84	43-62-0017	Carrying Handle	(1)
85	22-64-0012	120V Power Cord Assembly	(1)
88	43-62-0022	Feed Handle	(3)
89	31-17-0085	Cord Clamp	(1)
90	06-83-0015	2mm Hex Set Screw	(3)
92	23-66-0017	LED Switch Assembly	(1)

FIG.	PART NO.	DESCRIPTION OF PART	NO. REQ.
93	23-66-0041	Electromagnetic Switch	(1)
94	22-09-0110	Lower Board with LED	(1)
95	-----	Dovetail Rail	(2)
96	44-80-0061	Rack	(1)
97	-----	Slide	(1)
98	06-75-3050	1/4-20 x 3/4", 3/16" Hex Socket Hd. Screw	(2)
135	42-55-0140	Blow Molded Carrying Case	(1)
138	22-68-0020	Switch Cover	(1)
141	05-81-2787	1/4-20 x 1", 4.5mm Hex Button Hd. Screw	(4)
142	05-74-0013	3mm Hex Socket Head Cap Screw	(6)
146	45-56-0017	Safety Strap (Not Shown)	(1)
147	05-80-2787	M3 Flat Head Machine Screw	(2)
158	44-81-0070	Dovetail and Rail Kit	(1)
159	36-18-0030	Rack/Gear Shaft Assembly	(1)
160	43-78-0032	Quick Connect Hub Assembly	(1)
174	44-26-0075	Electromagnetic Base	(1)
175	22-09-0105	PCBA/Electronics Assembly	(1)
176	43-76-4272	Housing Assembly	(1)
177	42-20-0025	Support Housing	(1)
	10-20-0496	Danger Label	(1)
	12-20-4274	Service Nameplate (Not Shown)	(1)
	49-96-0035	Hex Key (Not Shown)	(1)

FIG.	PART NO.	DESCRIPTION OF PART	NO. REQ.
1	44-60-0433	Telescoping Pin for 2" Cutters	(1)
2	44-60-0007	Ejector Pin Assembly	(1)
3	48-66-0025	Chuck Collar	(1)
3a	34-60-0003	Retainer	(1)
3b	42-76-0017	Spindle Collar	(1)
3c	40-50-0336	Torsion Spring	(1)
3d	40-50-0097	Spring	(2)
3e	43-96-0015	Spindle Key	(1)
3f	32-75-0018	Spindle with Pin	(1)
3g	44-60-0004	Pin	(1)
4	-----	Spindle Plug	(1)
5	-----	Spring	(1)
6	34-60-0007	Retaining Ring	(1)
7	02-04-0011	Ball Bearing	(1)
8	06-82-7455	8-16 x 2.38 Pan Hd. Plastite T-20 Screw	(4)
9	05-81-1410	M4 x 16 Pan Hd. T-20 Screw	(1)
10	31-17-0030	Cord Clamp	(1)
11	44-10-0016	Adjustment Lever Assembly	(1)

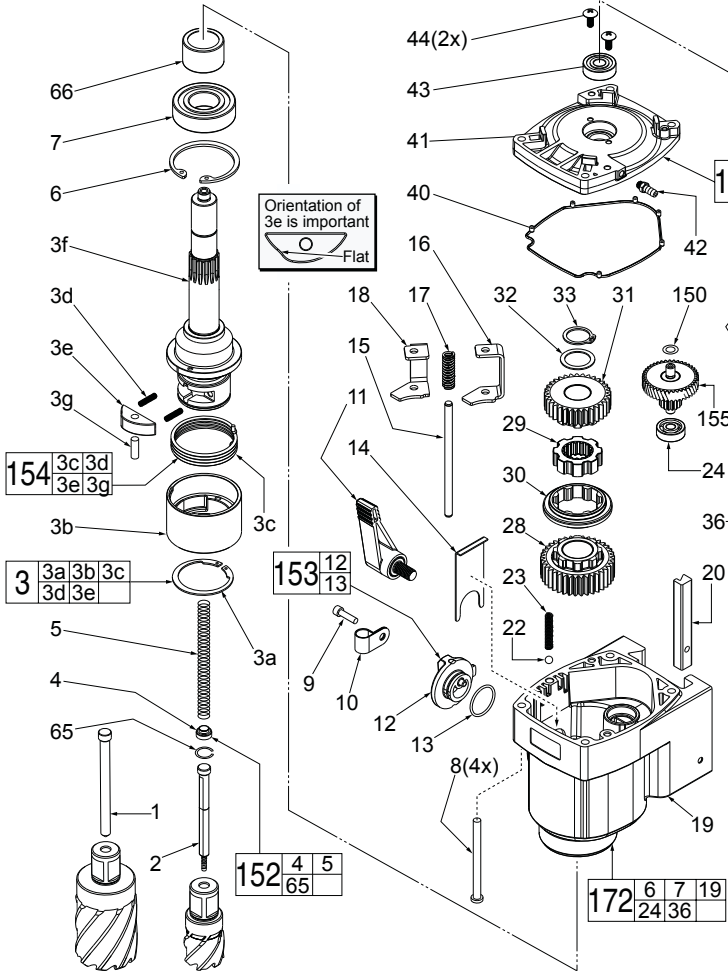
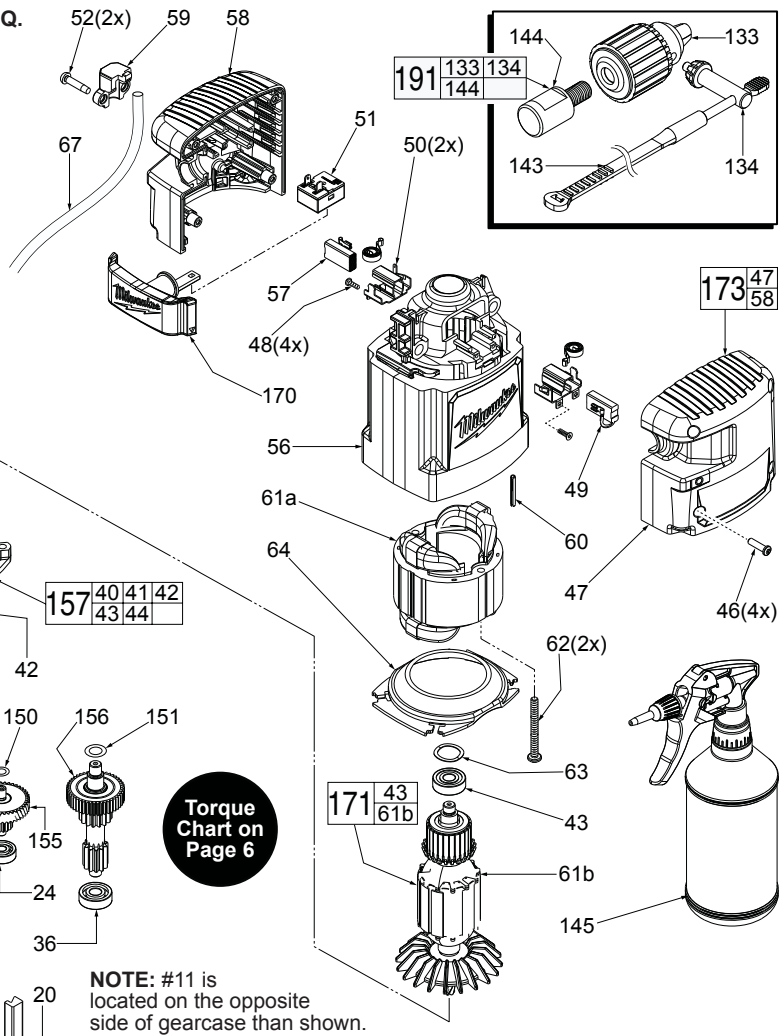

FIG.	PART NO.	DESCRIPTION OF PART	NO. REQ.
12	-----	Speed Knob	(1)
13	34-40-1570	O-Ring	(1)
14	44-90-0006	Shift Knob Retainer	(1)
15	44-94-0017	Guide Rod	(1)
16	42-36-0011	Shift Bracket 'B'	(1)
17	40-50-0023	Shift Spring	(1)
18	42-36-0018	Shift Bracket 'A'	(1)
19	-----	Gear Case with Pin	(1)
20	44-20-0021	Dovetail Lock Block	(1)
22	02-02-0103	Steel Ball	(1)
23	40-50-0038	Detent Spring	(1)
24	02-04-0640	Ball Bearing	(1)
28	32-40-0115	3rd Intermediate Gear, Low	(1)
29	43-12-0065	Drive Hub	(1)
30	42-90-0015	Coupler	(1)
31	32-40-0130	3rd Intermediate Gear, High	(1)
32	45-88-3140	Washer	(1)
33	34-60-0009	Retaining Ring	(1)
36	02-04-0820	Ball Bearing	(1)
40	43-44-0031	Gasket	(1)
41	-----	Diaphragm	(1)
42	43-33-0025	Lube Hose Fitting with O-Ring	(1)
43	02-04-0620	Ball Bearing	(2)
44	05-83-0020	M4 x 0.7 Round Head Phillips Screw	(2)
46	06-81-5383	M4 x 35mm Pan Hd. Plast. T-20 Screw	(4)
47	-----	Motor Housing Cover	(1)



NOTE: #11 is located on the opposite side of gearcase than shown.

FIG.	PART NO.	DESCRIPTION OF PART	NO. REQ.
48	05-81-0100	M3-24 x 10 Pan Hd. ST Phillips Screw	(4)
49	22-18-0215	120V Carbon Brush with Cut-Off	(1)
50	22-20-0135	Brush Holder Assembly with Spring	(2)
51	23-66-0635	On/Off Switch	(1)
52	05-88-1200	M4-18 x 1.4 Pan Hd. ST T-20 Screw	(2)
53	23-94-0560	Terminal Contact Wire Assy. (See Wiring)	(1)
56	31-50-0615	Motor Housing	(1)
57	22-18-0225	120V Carbon Brush without Cut-Off	(1)
58	-----	Motor Housing Support	(1)
59	31-17-0035	Cord Clamp	(1)
60	44-60-0381	Ground Pin	(1)
61a	18-01-0120	Field Assembly	(1)
61b	-----	Armature	(1)
62	06-82-7425	8-16 x 2" Slit. Pan Hd. Plastite T-20 Screw	(2)
63	45-88-0031	Wave Washer	(1)
64	42-14-0045	Fan Baffle	(1)
65	44-90-0012	Retainer	(1)
66	42-40-0101	Bushing	(1)
67	23-94-0032	120V Connection Cord	(1)
133	48-66-1355	Chuck	(1)
134	48-66-3280	Chuck Key	(1)
143	48-66-4040	Chuck Key Holder	(1)
144	-----	Chuck Adapter	(1)
145	42-51-0100	Lubricant Bottle	(1)
150	45-88-0621	Washer	(1)
151	45-88-0631	Washer	(1)
152	14-46-2787	Ejector Spring Kit	(1)
153	43-98-0071	Speed Knob Assembly	(1)
154	43-96-0091	Spring/Key Kit	(1)
155	14-29-0135	Pinion/2nd Intermediate Gear Assembly	(1)
156	14-29-0115	Pinion/1st Intermediate Gear Assembly	(1)
157	14-13-0040	Diaphragm Assembly w/ Bearings and Seal	(1)
170	42-42-0625	Switch Button Assembly	(1)
171	16-01-0120	Armature Assembly	(1)
172	14-30-0165	Gear Case Assembly	(1)
173	31-44-1265	Housing Support/Cover Assembly	(1)
191	49-59-0020	3/4" Weldon to 1/2" Chuck Adapter w/ Key	(1)