



SERVICE PARTS LIST

BULLETIN NO.
54-22-1028

SPECIFY CATALOG NO. AND SERIAL NO. WHEN ORDERING PARTS		REVISED BULLETIN	DATE
D. I. DIE GRINDER		54-22-1027	Oct. 2012
CATALOG NO.	5192	WIRING INSTRUCTION	
STARTING SERIAL NO.	669E	58-01-0309	

EXAMPLE:

00	0
----	---

 Component Parts (Small #) Are Included When Ordering The Assembly (Large #).

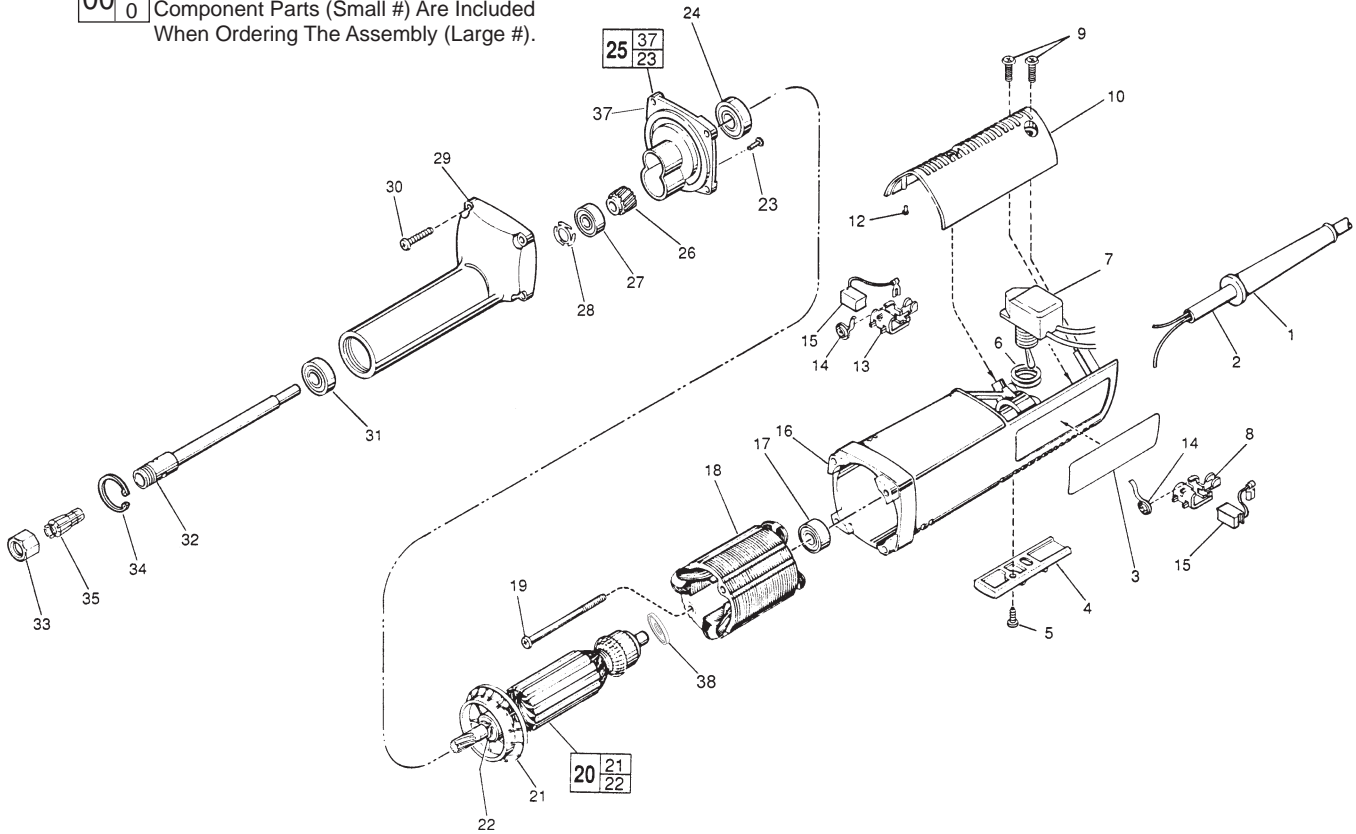
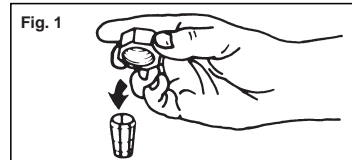

FIG.	PART NO.	DESCRIPTION OF PART	NO. REQ.
1	44-76-0130	Cord Protector	(1)
2	22-64-0215	Cord Set	(1)
3	12-20-0900	Service Nameplate Kit	(1)
4	31-55-0156	Trigger Cover	(1)
5	06-82-7409	8-16 x 1/2" Pan Hd. Plastite T-20 Screw	(1)
6	34-40-4015	O-Ring	(2)
7	23-66-2190	Switch	(1)
8	22-20-0691	Left Brush Holder	(1)
9	06-82-7270	8-16 x 5/8" Pan Hd. Stt. Plastite T-20 Scr.	(3)
10	31-15-0143	Motor Housing Cover	(1)
12	42-38-0181	Rubber Bumper	(2)
13	22-20-0692	Right Brush Holder	(1)
14	23-52-0240	Brush Spring	(2)
15	22-18-0710	Carbon Brush	(2)
16	31-50-0426	Motor Housing	(1)
17	02-04-0845	Ball Bearing	(1)
18	18-07-7100	120 Volt Field	(1)
★ 19	06-82-7430	8-16 x 2-1/8" Pan Hd. Plastite T-20 Scr.	(2)
★ 20	16-10-7100	120 Volt Armature	(1)
21	22-84-0680	Fan	(1)
22	34-60-0920	Ball Brg. Retaining Ring	(1)
23	06-82-5275	Pan Head Screw	(2)
24	02-04-1207	Ball Bearing	(1)
25	28-28-1906	Diaphragm Service Kit	(1)
26	32-75-2880	Spindle Gear	(1)
27	02-04-0845	Ball Bearing	(1)
28	45-88-7550	Finger Washer	(1)
29	28-50-7722	Spindle Housing	(1)
30	06-82-7296	7-18 x 1" Pan Hd. Stt. Plastite T-20 Scr.	(4)
31	02-04-1005	Ball Bearing	(1)
32	38-50-5211	Spindle Shaft	(1)
33	48-68-0031	1/4" Collet Nut	(1)
34	34-80-5090	Retaining Ring	(1)
35	48-66-0975	1/4" Collet	(1)
36	28-28-1901	Diaphragm	(1)

Collets

The collet must be attached to the collet nut before it is put into the collet shaft. Be sure that the size of the collet matches the size of the bit shank being used. If the wrong size bit shank is used, the collet may break. For attaching or detaching the collet nut to the collet, follow the illustrated instructions.

Attaching Collet to Collet Nut



To assemble, place the narrow end of the collet on an even surface. Take the nut and place it over the collet (Fig. 1).

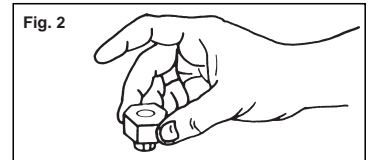

Position nut squarely over collet with the smaller opening of the nut facing up (Fig. 2).

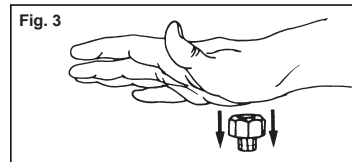

Snap nut and collet together by firmly applying downward pressure into assembly with palm of hand (Fig. 3).

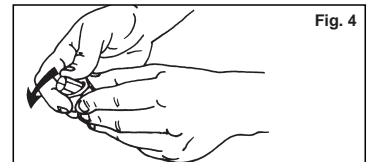

To remove collet from nut, hold nut firmly with one hand and press the collet to one side with the other hand (Fig. 4).

FIG.	PART NO.	DESCRIPTION OF PART	NO. REQ.
38	23-16-1670	Commutator Insulator	(1)
	49-96-4040	1/2" Open End Wrench	(1)
	49-96-4090	11/16" Open End Wrench	(1)

FIG. LUBRICATION

29 1/4 Oz. Type "G" Grease, No. 49-08-4140.

MILWAUKEE ELECTRIC TOOL CORPORATION
 13135 W. LISBON RD., BROOKFIELD, WI 53005