



# SERVICE PARTS LIST

**BULLETIN NO.**  
**54-24-1625**

SPECIFY CATALOG NO. AND SERIAL NO. WHEN ORDERING PARTS		REVISED BULLETIN	DATE
<b>1-9/16" (40mm) SDS-Max Rotary Hammer</b>			Mar. 2015
<b>CATALOG NO.</b>	<b>5317-20</b>	<b>WIRING INSTRUCTION</b>	
<b>STARTING SERIAL NO.</b>	<b>C84A</b>	<b>SEE PAGE 4</b>	

**EXAMPLE:**  
Component Parts (Small #) Are Included  
When Ordering The Assembly (Large #).

FIG.	PART NO.	DESCRIPTION OF PART	NO. REQ.
20	43-62-5316	Side Handle Assembly	(1)
20a	42-68-5316	Clamping Band	(1)
20b	06-54-5316	M8 x 6.5mm Square Nut	(1)
20c	44-40-5316	Clamp Holder	(1)
20d	43-98-5316	Side Handle	(1)
21a	05-78-5316	M4 x 14mm Pan Hd. Taptite T-20 (1 of 3)	(1)
22	42-36-5316	Belly Shroud	(1)
23	31-40-5316	Gearcase Assembly	(1)
24	14-46-5311	Ball Bearing and Rotary Seal Assembly	(1)
24a	45-06-5320	Rotary Seal	(1)
24b	34-40-5320	O-Ring	(1)
24c	02-04-5317	Ball Bearing	(1)
24d	45-88-5313	Snap Ring	(1)

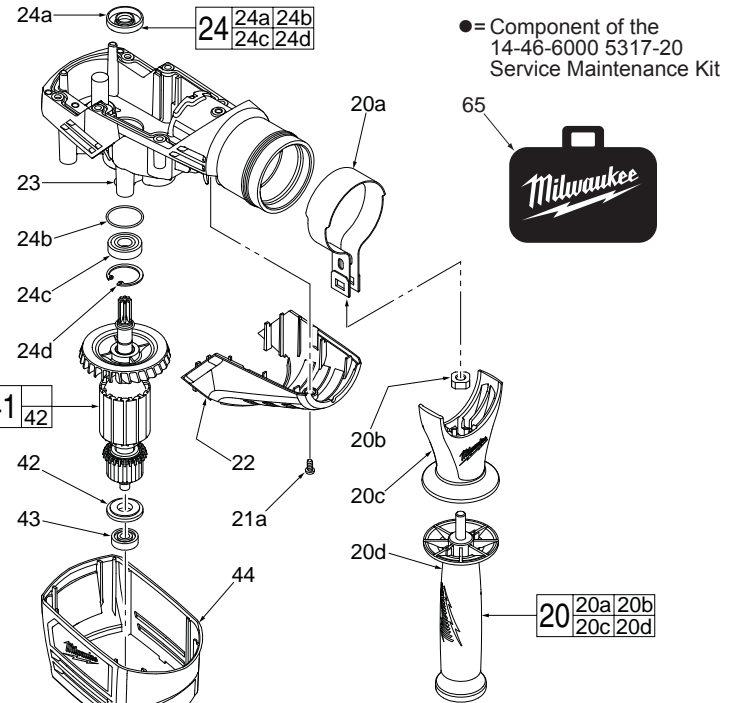

● = Component of the  
14-46-6000 5317-20  
Service Maintenance Kit

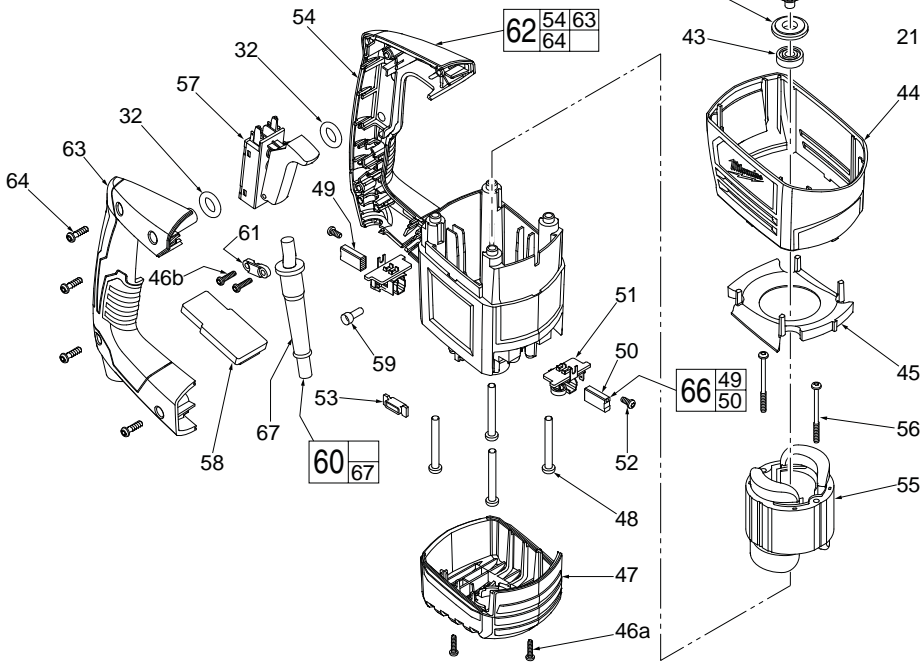
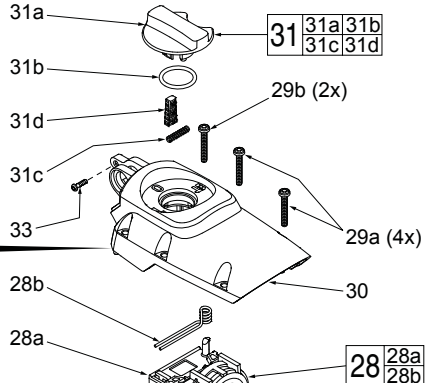
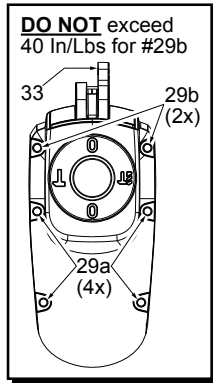

FIG.	PART NO.	DESCRIPTION OF PART	NO. REQ.
32	34-40-5308	● O-Ring	(2)
41	16-07-5316	Service Armature	(1)
42	-----	Magnet Ring	(1)
43	02-04-0530	Ball Bearing	(1)
44	23-16-5316	Motor Shroud	(1)
45	31-05-5316	Baffle	(1)
46a	06-82-0995	M4 x 16mm Pan Hd. Plastite T-20	(2)
46b	06-82-0995	M4 x 16mm Pan Hd. Plastite T-20	(2)
47	31-15-5316	Motor End Cover	(1)
48	06-95-5316	M6 x 50mm Pan Hd. Taptite T-30	(4)
49	-----	● Carbon Brush Assembly	(1)
50	-----	● Carbon Brush Assembly with Cut-Off	(1)
51	22-20-5316	Brush Holder Assembly	(2)
52	05-78-5313	M4 x 9mm Pan Hd. Plastite T-15	(2)
53	43-83-5317	Inductor Assembly	(1)
54	-----	Motor Housing	(1)
55	18-07-5316	Service Field	(1)
56	05-78-5314	M4.5 x 56mm ST T-30	(2)
57	23-66-5315	Trigger Switch	(1)
58	22-09-5317	PCB Assembly	(1)
59	22-56-5317	Close End Connector	(1)
60	22-64-5316	Power Cord with Strain Relief	(1)

FIG.	PART NO.	DESCRIPTION OF PART	NO. REQ.
61	31-17-0155	Cord Clamp	(1)
62	31-40-5317	Motor Housing and Handle Cover Assembly	(1)
63	-----	Handle Cover	(1)
64	05-78-5311	M5 x 18mm ST Pan Hd. Plastite T-20	(4)
65	42-55-5317	Carrying Case	(1)
66	22-18-6025	● Brush Service Kit (Set of 2)	(1)
67	44-76-0210	Strain Relief	(1)
	12-20-5306	Service Nameplate (Not Shown)	(1)

• See page 2 for the exploded view and parts listing of the mechanical portion of the tool and service fixtures.  
• See page 3 for lubrication instructions, torques chart, maintenance instructions and service kits.  
• See Page 4 for wiring instructions.



37 18b 37a  
37b 37c

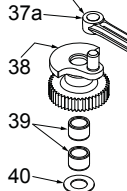

There are slightly smaller teeth on one side of drive sleeve #35 that are to face the spindle bevel gear #34.

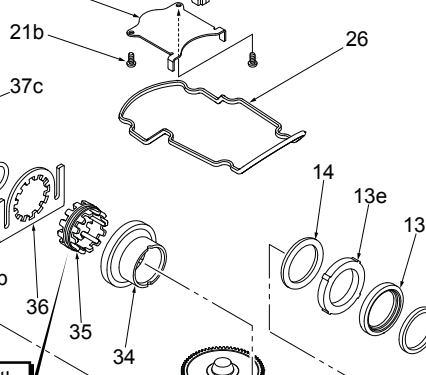

FIG.	PART NO.	DESCRIPTION OF PART	NO. REQ.
18a	45-56-5320	Striker	(1)
18b	34-40-5310	O-Ring	(2)
19	45-88-5314	Washer	(1)
21b	05-78-5316	M4 x 14mm Pan Hd. Taptite T-20 (2 of 3)	(2)
23	31-40-5316	Gearcase Assembly	(1)
25	32-10-5316	Clutch Assembly	(1)
26	45-06-5316	Rubber Gasket	(1)
27	44-66-5313	Selector Bracket Clamp Plate	(1)
28	14-46-5312	Fork Assembly	(1)
28a	-----	Fork	(1)
28b	-----	Fork Assembly Spring	(1)
29a	05-78-5315	M5 x 33mm Pan Hd. Taptite T-25	(4)
29b	05-78-5315	M5 x 33mm Pan Hd. Taptite T-25	(2)
30	28-20-5316	Gearcase Cover	(1)
31	23-66-5316	Selector Knob Assembly	(1)
31a	43-98-5321	Selector Knob	(1)
31b	34-40-5309	O-Ring	(1)
31c	40-50-5320	Spring	(1)
31d	44-62-0710	Rubber Plug	(1)
33	06-82-8828	#8-32UNC x .313" Pan Hd. Taptite T-20	(1)
34	32-75-5316	Spindle Bevel Gear	(1)
35	45-22-5316	Drive Sleeve	(1)
36	44-66-5312	Locking Plate	(1)
37	14-09-5316	Piston and Connecting Rod Assembly	(1)

13 13a 13b 13c  
13d 13e

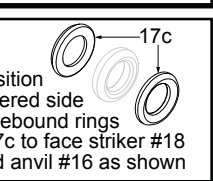
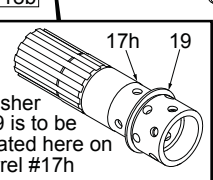
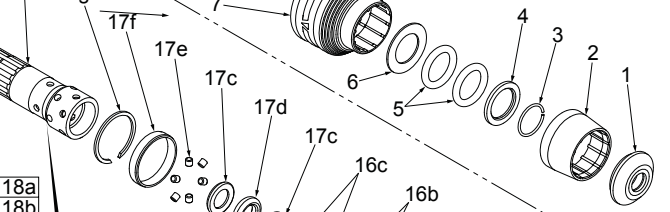
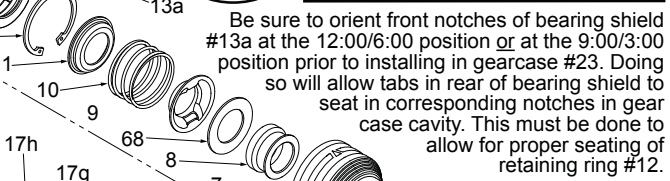
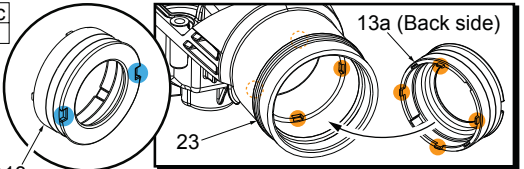

FIG.	PART NO.	DESCRIPTION OF PART	NO. REQ.
37a	44-94-0710	Connecting Rod	(1)
37b	-----	Piston	(1)
37c	-----	Wrist Pin	(1)
38	36-17-5317	Crank Shaft	(1)
39	02-50-5315	Needle Bearing	(2)
40	45-88-5327	Washer	(1)
68	45-88-5371	Washer	(1)

SERVICE FIXTURES FOR THE 5317-20 SDS ROTARY HAMMER	
PART NO.	DESCRIPTION OF FIXTURE
61-10-1027	Armature Press Gauge
61-10-1030	Seal Driver
61-10-1032	Seal Expander
61-10-1035	Anvil Insertion Guide
61-10-1037	Seal Driver

FIG.	PART NO.	DESCRIPTION OF PART	NO. REQ.
1	45-12-5316	Rubber Dust Shield	(1)
2	45-22-5317	Front Latch Sleeve	(1)
3	34-60-5316	Retaining Ring	(1)
4	45-88-5316	Washer	(1)
5	34-40-5316	Spindle O-Ring	(2)
6	45-88-5321	Washer	(1)
7	45-22-5319	Sliding Collar	(1)
8	45-22-5321	Locking Sleeve	(1)
9	44-66-5316	Front Spring Retainer	(1)
10	40-50-5318	Spring	(1)
11	44-66-5314	Rear Spring Retainer	(1)
12	34-40-5315	Retaining Ring	(1)
13	14-46-5316	Bearing Shield Assembly	(1)
13a	-----	Bearing Shield	(1)
13b	34-40-5321	O-Ring	(2)
13c	45-06-5170	Felt Seal	(1)
13d	45-06-5180	Rotary Seal	(1)
13e	02-50-5316	Bearing Ring	(1)
14	45-88-5323	O-Ring	(1)
15	44-20-5316	Key	(2)
16	42-06-5316	Anvil Assembly	(1)
16a	-----	Anvil	(1)
16b	34-60-5319	O-Ring	(2)
16c	45-06-5317	Turcon Seal	(2)
17	38-50-5316	SDS-Max Spindle Assembly	(1)
17a	44-82-5317	SDS-Max Spindle	(1)
17b	43-06-5317	Brake Ring	(1)
17c	45-88-5325	Rebound Ring	(2)
17d	34-60-5321	Back Press Ring	(1)
17e	44-60-5316	Spindle Sleeve Pin	(6)
17f	44-90-5317	Steel Ring	(1)
17g	44-90-5319	Spring Ring	(1)
17h	38-50-5323	Barrel	(1)
18	45-56-5316	Striker Assembly	(1)