



SERVICE PARTS LIST

BULLETIN NO.
54-24-0105

SPECIFY CATALOG NO. AND SERIAL NO. WHEN ORDERING PARTS				REVISED BULLETIN	DATE
1-1/32" (26mm) ROTARY HAMMER - Mexico					Oct. 2014
CATALOG NO.	5386-21	SERIAL NUMBER	E88A	WIRING INSTRUCTION See page 4	

EXAMPLE:
Component Parts (Small #) Are Included
When Ordering The Assembly (Large #).

FIG.	PART NO.	DESCRIPTION OF PART	NO. REQ.
2	05-81-5265	SCREW, 5X32 T20	4
6	22-64-5262	POWERCORD ASSY	1
100	31-44-5390	HOUSING ASSY	1
104	-----	MOTOR ASSY	1
105	18-07-5395	FIELD 127V	1
106	16-07-5395	ARMATURE 127V	1
107	-----	FAN	1
108	02-04-5262	BALL BEARING	1
109	-----	WASHER	1
110	-----	INSULATING DISC	1
117	-----	WIRE	1
118	-----	WIRE	1
119	05-81-5262	SCREW, 4X18 T15	6
131	22-18-5262	SET COLLAR & BRUSH ASSY 110V	1

● = Component of 14-46-5395
127V Rotary Hammer Service Kit
(See page 2 for complete list)

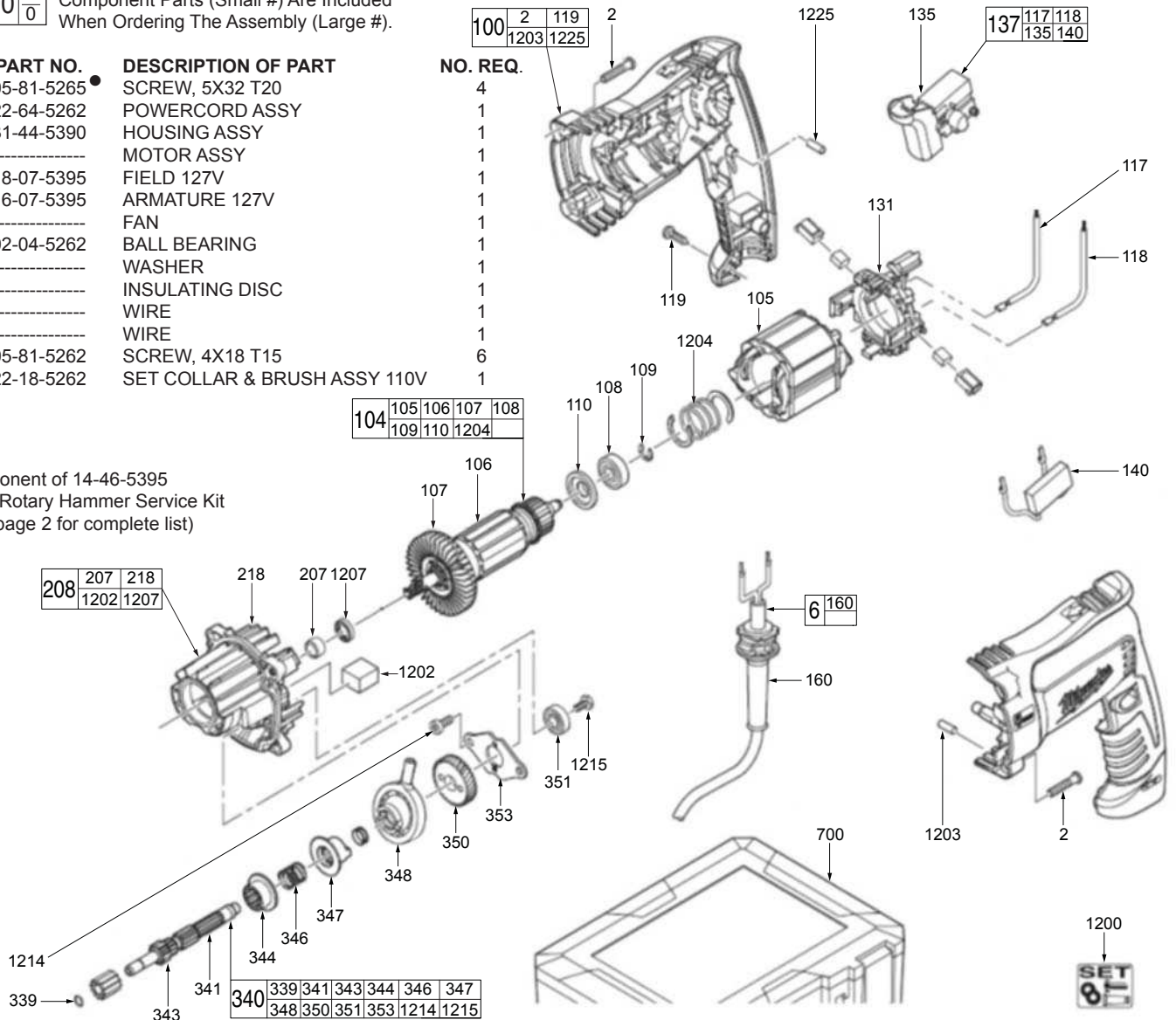
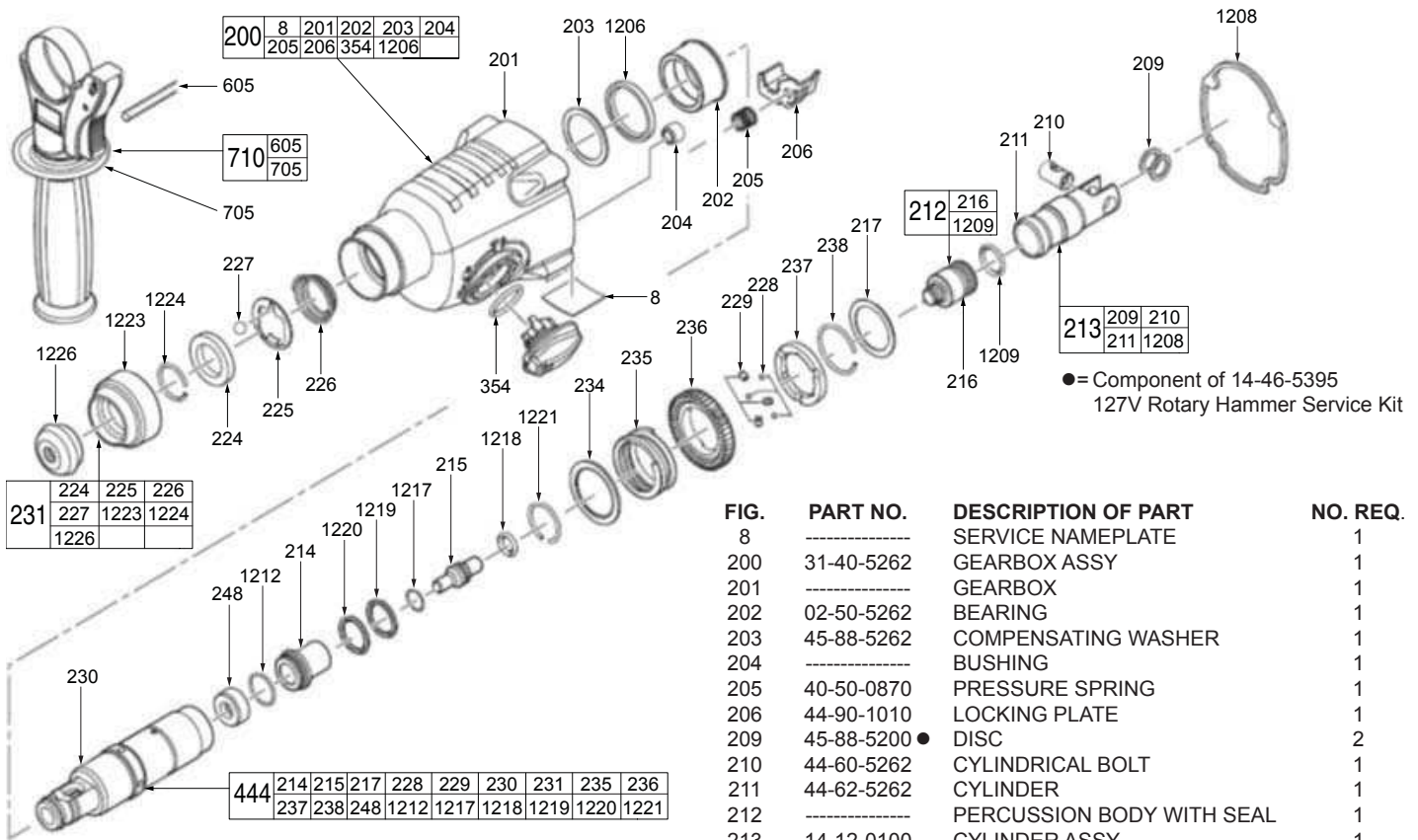

FIG.	PART NO.	DESCRIPTION OF PART	NO. REQ.
135	-----	SWITCH BOARD 127V	1
137	23-66-5395	SWITCH ASSY 127V	1
140	-----	CAPACITOR	1
160	44-76-0210	CORD PROTECTOR	1
203	45-88-5262	COMPENSATING WASHER	1
207	-----	NEEDLE BEARING	1
208	28-28-5262	DIAPHRAGM ASSY	1
218	-----	END PLATE	1
339	44-90-1180	SPRING RING	1
340	-----	WOBBLE DRIVE ASSY	1
341	36-66-5261	REDUCTION GEAR SHAFT	1
343	32-60-1610	GEAR	1
344	32-60-1620	INTERN:GEARED WHEEL	1
346	40-50-2140	PRESSURE SPRING	1
347	45-22-0925	COUPLING SLEEVE	1
348	36-92-0800	WOBBLE DRIVE	1
350	32-05-5262	REDUCTION GEAR WHEEL	1
351	02-04-5385	BALL BEARING	1
353	42-36-5261	BEARING COVER	1

FIG.	PART NO.	DESCRIPTION OF PART	NO. REQ.
700	42-55-5386	CARRYING CASE MILWAUKEE	1
1200	14-46-5395	127V Rotary Hammer Service Kit	1
1202	43-84-1050	FELT	1
1203	44-60-5270	HOLDING DOWN DEVICE	1
1204	45-88-0017	REPAIR KIT	1
1207	45-06-5263	SEAL RING	1
1214	05-74-1030	SCREW 5X12 T25	2
1215	05-74-1020	SCREW	1
1225	-----	HOLDING DOWN DEVICE	1



● = Component of 14-46-5395
127V Rotary Hammer Service Kit

231	224	225	226
	227	1223	1224
	1226		

444	214	215	217	228	229	230	231	235	236
	237	238	248	1212	1217	1218	1219	1220	1221

FIG.	PART NO.	DESCRIPTION OF PART	NO. REQ.
8	-----	SERVICE NAMEPLATE	1
200	31-40-5262	GEARBOX ASSY	1
201	-----	GEARBOX	1
202	02-50-5262	BEARING	1
203	45-88-5262	COMPENSATING WASHER	1
204	-----	BUSHING	1
205	40-50-0870	PRESSURE SPRING	1
206	44-90-1010	LOCKING PLATE	1
209	45-88-5200 ●	DISC	2
210	44-60-5262	CYLINDRICAL BOLT	1
211	44-62-5262	CYLINDER	1
212	-----	PERCUSSION BODY WITH SEAL	1
213	14-12-0100	CYLINDER ASSY	1
214	45-22-0870	CORE LIFTER RING	1
215	45-08-0650	SNAP DIE	1
216	45-56-0300	PERCUSSION BODY	1
217	45-88-5230	DISC	1
224	44-90-5265	HOLDING RING	1
225	40-50-5262	SUPPORT PLATE	1
226	42-36-5262	PRESSURE SPRING	1
227	02-02-0275	BALL	1
228	02-02-1230	BALL	3
229	44-96-0300	CYLINDRICAL BOLT	3
230	38-50-5262	SPINDLE SLEEVE	1
231	-----	SLEEVE ASSY	1
234	45-88-2115	STOP DISC	1
235	40-50-1720	SPRING	1
236	32-75-1830	SPINDLE GEAR	1
237	42-70-5262	CLUTCH DISC	1
238	44-90-0215 ●	SPRING RING	1
248	45-88-2100	STOP WASHER	1
354	44-10-5262	SWITCH LEVER	1
444	-----	SPINDLE ASSY	1
605	44-94-5381	DEPTH GAUGE	1
705	31-05-5263	HANDLE	1
710	-----	HANDLE ASSY	1
1200	14-46-5395	127V Rotary Hammer Service Kit	1
1206	45-06-0062	SEAL RING	1
1208	43-44-5262 ●	SEAL	1
1209	34-40-1510 ●	SEAL RING	1
1212	34-40-1425 ●	O-RING	1
1217	34-40-1410 ●	SEAL RING	1
1218	34-40-1450 ●	O-RING	1
1219	42-76-1000	THRUST COLLAR	1
1220	34-40-1440 ●	SEAL RING	1
1221	44-90-1025 ●	SPRING RING	1
1223	42-76-5262 ●	SLEEVE	1
1224	44-90-5262 ●	SPRING RING	1
1226	42-52-5262 ●	CAP	1

●14-46-5395

127V Rotary Hammer Service Kit

1226	42-52-5262	Dust Cap	(1)
1223	42-76-5262	Locking Sleeve	(1)
1224	44-90-5262	C-Ring	(1)
1212	34-40-1425	O-Ring	(1)
1220	34-40-1440	O-Ring	(1)
1217	34-40-1410	O-Ring	(1)
1218	34-40-1450	O-Ring	(1)
1221	44-90-1025	C-Ring	(1)
238	44-90-0215	Retaining Ring	(1)
1209	34-40-1510	O-Ring	(1)
209	45-88-5200	Washer	(2)
1208	43-44-5262	Gasket	(1)
131	22-18-5262	Carbon Brush Assy.	(1)
339	44-90-1180	C-Ring	(1)
1214	05-74-1030	M5.0 x 0.8 Screw	(2)
1215	05-74-1020	M4.0 x 0.7 Screw	(1)
2	05-81-5265	Taplrite Screw	(4)
	49-08-5350	'P' Grease 100g tube	(1)
	49-08-5345	'Q2' Grease 45g tube	(1)