



# SERVICE PARTS LIST

**BULLETIN NO.**  
**54-37-0225**

SPECIFY CATALOG NO. AND SERIAL NO. WHEN ORDERING PARTS		REVISED BULLETIN	DATE
<b>2.25 MAX. H.P. BODY GRIP ROUTER w/ ELECTRONICS</b>			Apr. 2013
CATALOG NO. <b>5616-20/5616-29</b>	SERIAL NUMBER <b>A19A</b>	WIRING INSTRUCTION <b>58-01-0717</b>	

**EXAMPLE:**  

00	0
----	---

 Component Parts (Small #) Are Included When Ordering The Assembly (Large #).

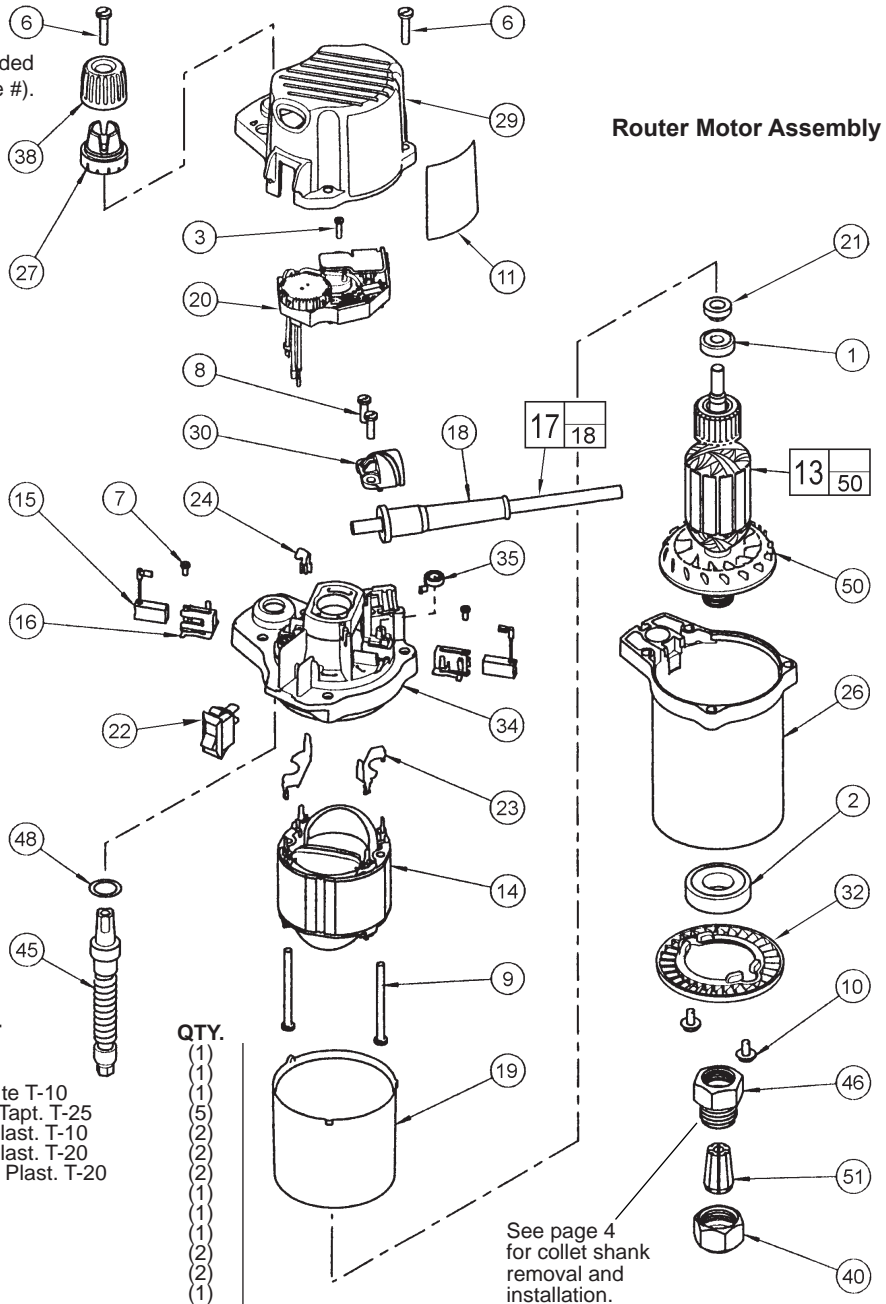

FIG.	PART NO.	DESCRIPTION OF PART	QTY.
1	02-04-0852	Ball Bearing	(1)
2	02-04-2006	Ball Bearing	(5)
3	06-82-7225	4-20 x 1/2" Pan Hd. Plastite T-10	(2)
6	06-82-5574	10-24 x 7/8" Pan Hd. Slit. Tapt. T-25	(2)
7	06-82-7212	4-20 x 1/4" Pan Hd. Slit. Plast. T-10	(2)
8	06-82-7270	8-16 x 5/8" Pan Hd. Slit. Plast. T-20	(2)
9	06-82-7455	8-16 x 2-3/8" Pan Hd. Slit. Plast. T-20	(2)
11	12-20-0255	Service Nameplate Kit	(1)
13	16-30-0015	Armature	(1)
14	18-30-1015	Field	(1)
15	22-16-0410	Carbon Brush	(2)
16	22-22-0165	Brush Tube	(2)
17	22-64-0320	Cord Set Assembly	(1)
18	44-76-0210	Cord Protector	(1)
19	23-16-0405	Field Insulator	(1)
20	14-20-0055	Electronic Feedback Module	(1)
21	23-38-0200	Tachometer	(1)
22	23-66-2280	Rocker Switch	(1)
23	23-74-0025	Field Terminal	(2)
24	23-74-0055	Connector Terminal	(1)
26	28-50-0105	Motor Housing	(1)
27	31-01-0025	Depth Scale	(1)
29	31-15-0095	Motor Cover	(1)
30	31-17-0070	Cord Clamp	(1)
32	31-55-0025	Contamination Shield	(1)
34	31-50-0106	Motor Frame	(1)
35	40-50-0190	Brush Spring	(2)
38	43-98-0531	Depth Knob	(1)
40	44-40-0095	Collet Nut (2 supplied with tool)	(1)
45	45-08-0030	Depth Shaft Assembly	(1)
46	45-10-0081	Collet Shank (See reverse)	(1)
48	45-88-0045	Washer	(1)
50	22-84-0380	Fan Assembly	(1)
51	48-66-0985	1/4" Collet	(1)
51	48-66-1010	1/2" Collet	(1)
	49-96-0365	1-1/8" Open End Wrench (Not Shown)	(2)
	49-96-0370	T-Handle Depth Adjustment Wrench (Not Shown)	(1)

**FIG. NOTES:**  
 16,34,35 When servicing the motor frame (34) and the brush tube (16) has to be removed, replace with a new brush tube. Note: Make sure that the brush spring (35) is positioned properly onto the new motor frame to insure proper brush tension to the commutator.  
 21 Press tachometer (21) flush ±.020 to the end of the armature shaft (13). Conical side to the bearing (1).  
 40,51 Collet must be snapped into the collet nut prior to assembly onto the collet shank.

**MILWAUKEE ELECTRIC TOOL CORPORATION**  
 13135 W. LISBON RD., BROOKFIELD, WI 53005

48-10-5615  
Router BodyGrip Assembly

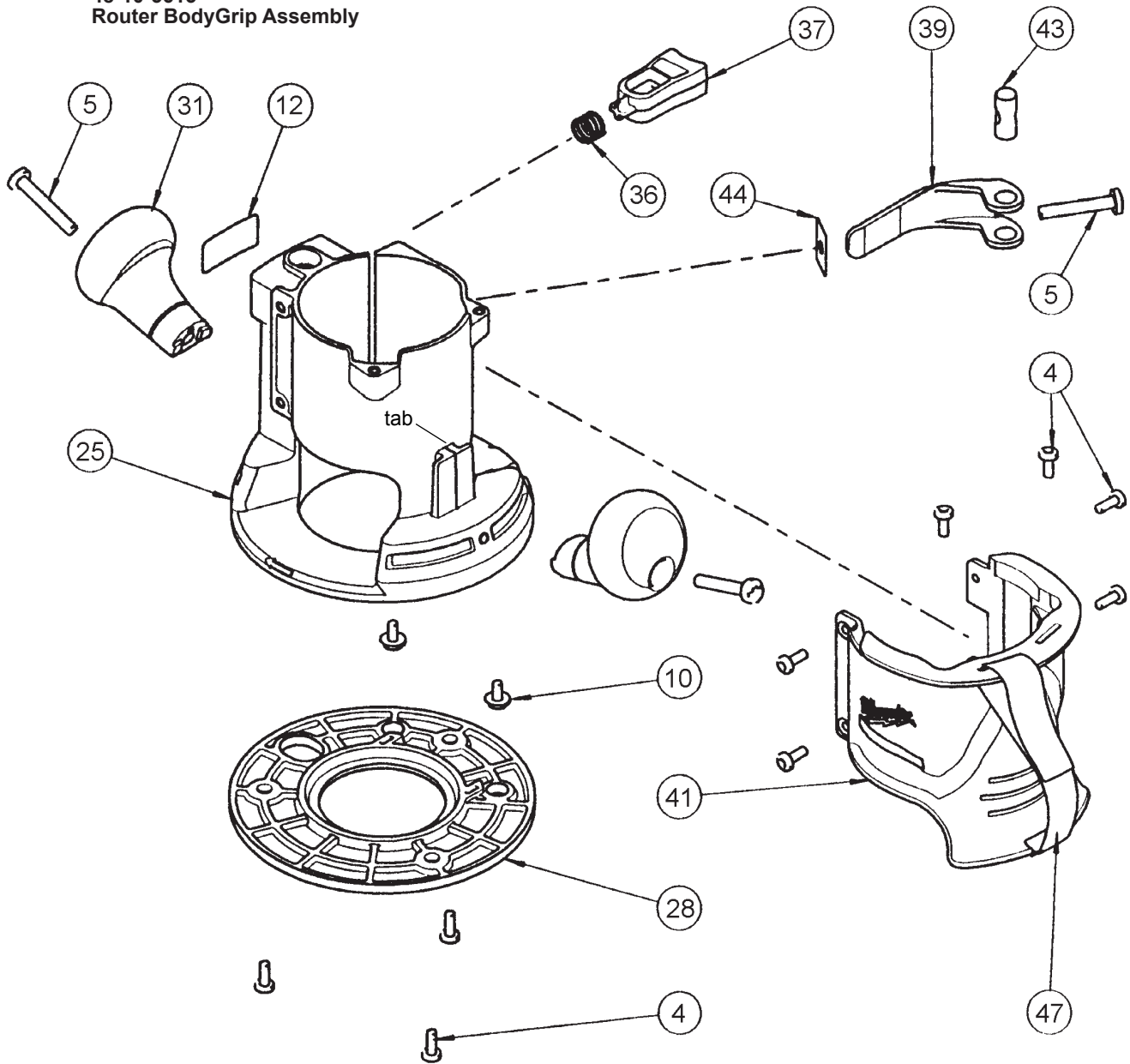

FIG.	PART NO.	DESCRIPTION OF PART	QTY.
4	06-82-5314	10-24 x 1/2" Slit. Pan Hd. Tapt. T-25	(9)
5	06-82-5514	1/4-20 x 1-1/2" Slit. Pan Hd. Tapt. T-30	(3)
10	06-82-8865	10-32 x 7/16" Pan Hd. Tapt. Sems T-25	(4)
12	12-25-0235	Nameplate	(1)
25	26-06-0100	Base	(1)
28	49-54-1045	Sub Base	(1)
31	31-44-0130	Knob Handle	(2)
36	40-50-4005	Compression Spring	(1)
37	42-42-0126	Release Button	(1)
39	44-10-0435	Base Clamp Lever	(1)
41	44-52-0020	Body Grip	(1)
43	44-60-0095	Thru Pin	(1)
44	44-66-0035	Wear Plate	(1)
47	45-56-0225	Handle Strap Assembly	(1)

**FIG. 5,39 NOTES:**  
Clamping force for the base clamp lever (39) is adjusted with base clamp screw (5). Tighten the screw using 10-20 lbs. force to close the lever to the locked position. Motor unit must be in base when checking force.

25,36,37 To service the release button (37) and the compression spring (36) a long, thin tool like a flat blade screwdriver must be used. From the bottom of the base (25), insert the screwdriver into the cavity located under the release button. Press on the button detent to release.

25,41,47 The metal clip from the handle strap (47) is to be placed around the tab on the base (25). The body grip (41) is to be placed onto the base from the top so that the cavity on the inside of the body grip slips over the tab on the base, securing the handle strap.

39,43 Apply a thin coat of "L" grease, No. 49-08-4170, to the pivot surface areas of the base clamp lever (39). Apply a thin coat of grease to the surface of the thru pin (43).

**48-10-5600  
Router Plunge  
Base Assembly**

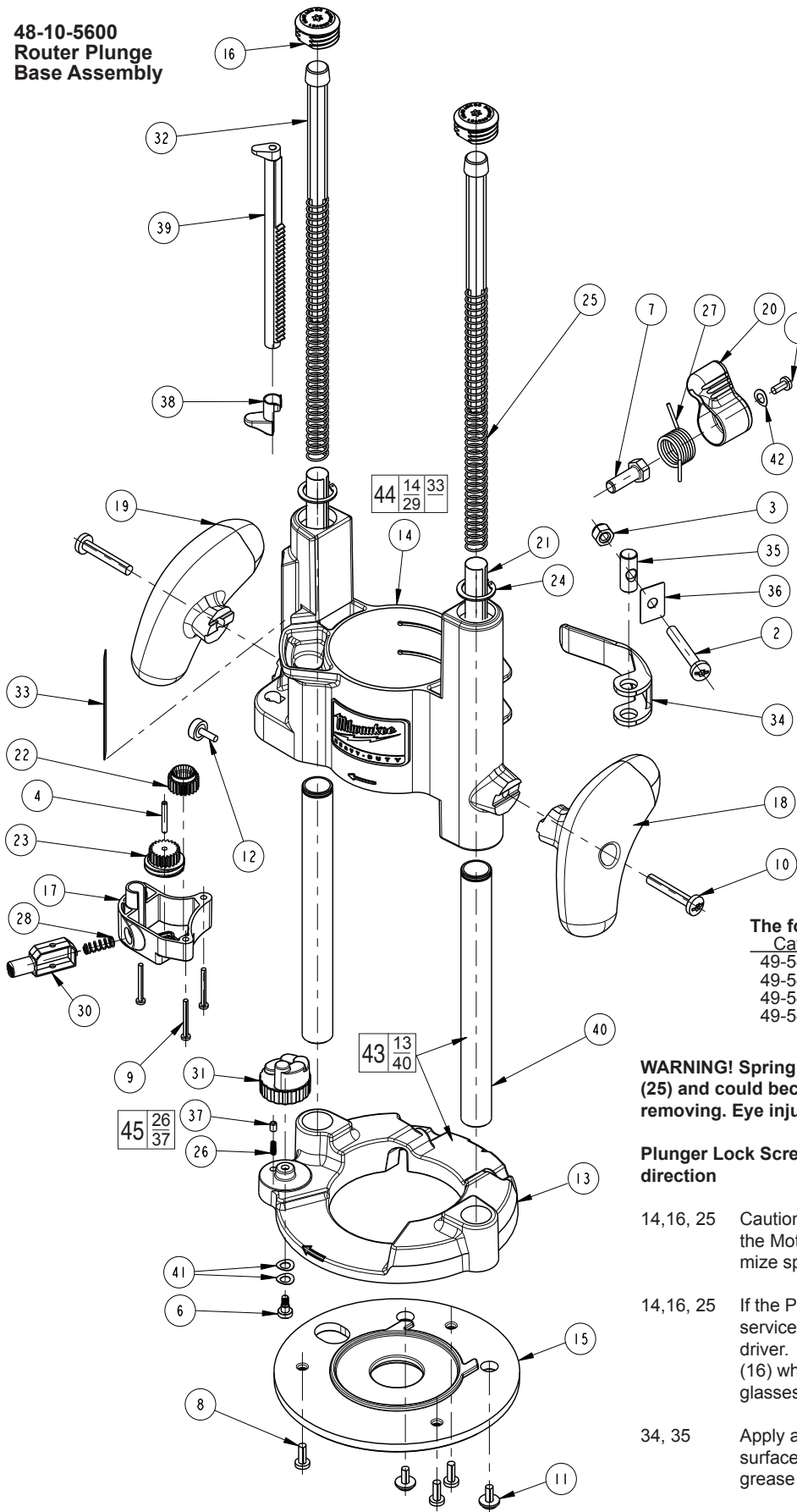

FIG.	PART NO.	DESCRIPTION OF PART	QTY.
1	05-81-1005	Screw 8-32 x .394 T20	(1)
2	06-14-0080	Bolt 1/4-20 x 1.75 T30	(1)
3	06-57-6075	Lock Nut	(1)
4	06-65-0700	Gear Pin	(1)
6	06-75-0410	Shoulder Bolt M4 T25	(1)
7	06-81-1980	Plunge Lock Screw	(1)
8	06-82-5314	10-24 x .5 Pan Tap Torx	(3)
9	06-82-5315	Screw ST M3 x 26.5 mm T10	(3)
10	06-82-5514	T30, 1/4 - 20 x 1.50 Taptite	(2)
11	06-82-8865	Slotted Torx Taptite Screw	(2)
12	06-87-0100	Depth Rod Locking Screw	(1)
13	-----	Base	(1)
14	-----	Motor Carriage	(1)
15	-----	Subbase (See Chart)	(1)
16	31-12-0380	Spring Cap	(2)
17	31-40-0190	Gear Housing	(1)
18	31-44-2530	Right Handle	(1)
19	31-44-2535	Left Handle	(1)
20	31-52-0120	Plunge Lock Lever	(1)
21	31-55-0500	Spring Shield Tube	(2)
22	32-40-2380	Gear with Hex	(1)
23	32-40-2385	Gear with Screw	(1)
24	34-60-3705	Retaining Ring	(2)
25	40-50-1395	Plunge Spring	(2)
26	-----	Spring	(1)
27	40-50-1410	Torsion Spring	(1)
28	40-50-1415	Spring	(1)
29	-----	Bushing (not shown)	(4)
30	42-42-1050	Gear Release Button	(1)
31	42-46-0250	Turret	(1)
32	43-56-0915	Spring Guide	(2)
33	43-82-0175	Scale	(1)
34	44-10-0435	Base Clamp Lever	(1)
35	44-60-0095	Pin, Thru	(1)
36	44-66-0035	Wear Plate	(1)
37	-----	Detent Pin	(1)
38	44-72-0100	Depth Rod Pointer	(1)
39	44-94-0460	Depth Stop Rod	(1)
40	-----	Plunge Rod	(2)
41	45-88-0995	Spring Washer	(2)
42	05-90-0225	M4 Spring Washer	(1)
43	14-46-5600	Base and Plunge Rod Kit	(1)
44	14-46-5605	Motor Carriage Kit	(1)
45	14-46-5610	Spring Assembly	(1)

**The following sub-bases (15) are compatible with this base:**

Cat. No.	Outside dia.	Center hole dia.	Color
49-54-1027	6"	1-3/16"	Clear
49-54-1028	6"	2-1/2"	Clear
49-54-1040	6"	1-3/16"	Black
49-54-1045	6"	2-1/2"	Black

**WARNING! Spring Caps (16) are under pressure from Plunge Springs (25) and could become projectiles when loosened. Use caution when removing. Eye injury could occur. Always wear safety glasses.**

**Plunger Lock Screw (7) is LH Thread – tightens in counter-clockwise direction**

14, 16, 25 Caution! Before removing Spring Caps (16) always release/bring the Motor Carriage (14) to the upward most height setting to minimize spring (25) tension.

14, 16, 25 If the Plunge Springs (25) or Motor Carriage (14) need to be serviced, remove Spring Caps (16) with a T-40 Tamper Proof style driver. Note: Always cover / hold your hand over the spring caps (16) when removing or installing springs (25). Always wear safety glasses.

34, 35 Apply a thin coat of "L" grease, No. 49-08-4170, to the pivot surface areas of the base clamp lever (34). Apply a thin coat of grease to the surface of the thru pin (35).

14, 20, 24, 40 To aid in the removal of Retaining Rings (24) from the Plunger Rods (40). (springs (25) and plunger caps (16) removed previously) Push Plunge Lock Lever (20) down and Lower Motor Carriage (14) down until Retaining Rings (24) are just below the internal Spring Cap threads inside the Motor Carriage.