



SERVICE PARTS LIST

BULLETIN NO.
54-38-2171

SPECIFY CATALOG NO. AND SERIAL NO. WHEN ORDERING PARTS		REVISED BULLETIN 54-38-2170	DATE Mar. 2016
5" COMPACT RAT-TAIL ANGLE GRINDER		WIRING INSTRUCTION See Reverse Side	
CAT. NO.	6121-31A	STARTING SERIAL NUMBER	C98B

FIG.	PART NO.	DESCRIPTION OF PART	NO. REQ.
1	05-88-1650	M4 x 25mm Pan Hd. ST Screw T-20	(7)
2	42-62-0120	Side Handle Assembly	(1)
3	14-30-1155	Gearcase Assembly	(1)
3a	-----	Spindle Lock Button	(1)
3b	-----	Spindle Lock Spring	(1)
3c	-----	Gearcase	(1)
3d	-----	O-Ring	(1)
3e	-----	Spindle Lock Pin	(1)
3f	-----	Needle Bearing	(1)
3g	02-04-0620	Ball Bearing	(1)
4	34-40-0560	O-Ring	(1)
★ 5	14-46-0417	5/8" Spindle Hub Kit	(1)
★ 5a	-----	Spiral Bevel Gear	(1)

★ = Part number change from previous service parts list.

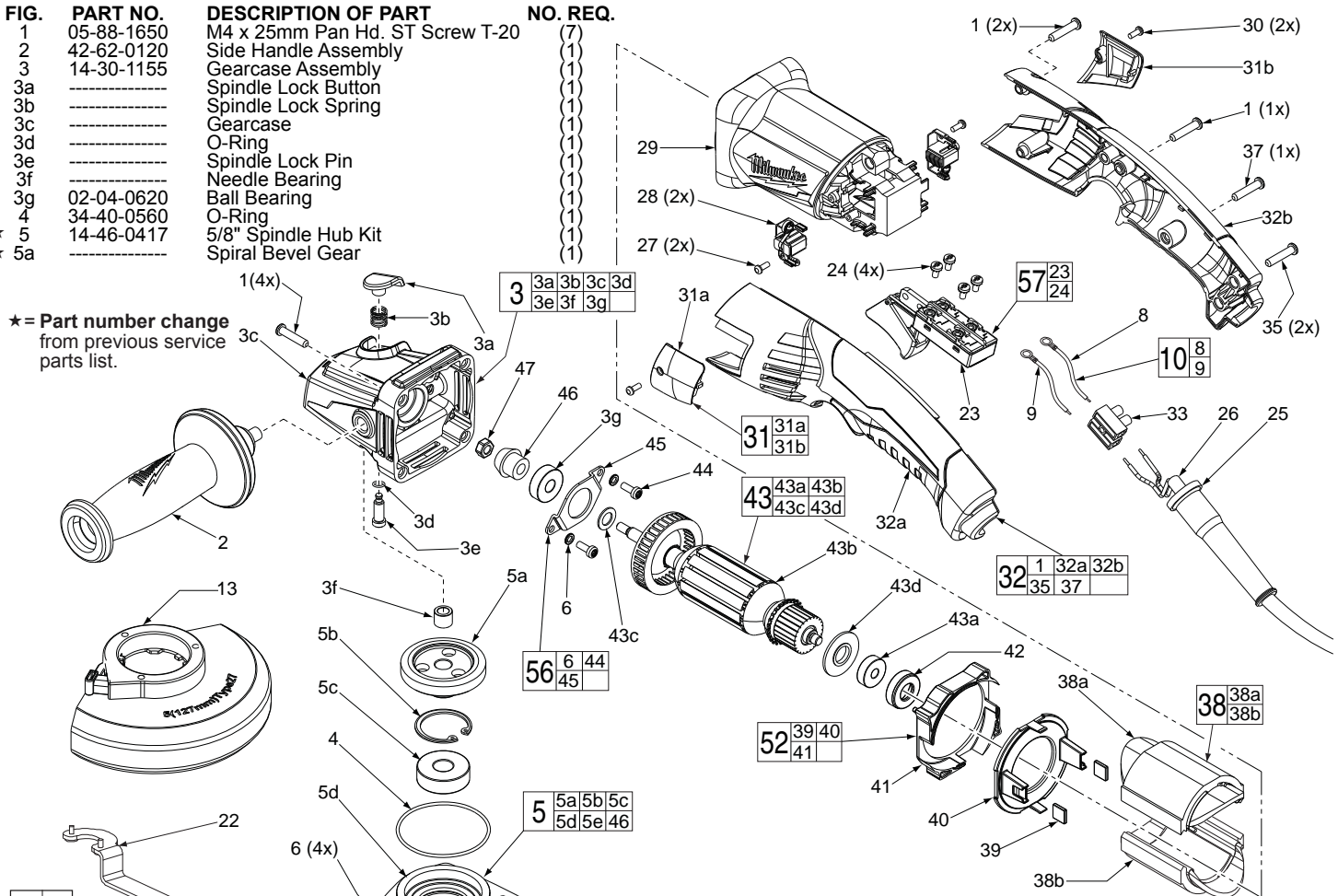

EXAMPLE:
Component Parts (Small #)
Are Included When Ordering
The Assembly (Large #).

***LUBRICATION NOTE:**
When servicing the Gears (5a & 46) or the Gearcase (3c), 90-95% of the old grease must be removed prior to new grease being added.

FIG. LUBRICATION*
5a,46 Type "Y" Grease, No. 49-08-5270, Must Be Applied To All Gear Teeth.

5b	-----	Retaining Ring	(1)
5c	-----	Ball Bearing	(1)
5d	-----	Spindle Hub	(1)
5e	-----	5/8" Spindle	(1)
6	05-90-0225	Spring Washer	(6)
7	05-88-1210	M4 x 14mm T-20	(4)
8	-----	Leadwire - Black	(1)
9	-----	Leadwire - White	(1)
10	23-94-0345	Leadwire Assy. Kit	(1)
13	14-32-0215	5" Type 27 Guard Assembly (Shown)	(1)
13	43-54-0925	5" Type 1 Guard Assy. (Not Shown)	(1)
15	-----	O-Ring	(1)
16	-----	Wavey Spring	(1)
17	-----	Flange with Ramps	(1)
18	-----	Retaining Ring	(1)
19	43-34-0935	Inner Disc Flange	(1)
21	44-40-0035	Outer Flange Nut	(1)
22	49-96-7205	Spanner Wrench	(1)
23	23-66-2685	Trigger Switch	(1)
24	05-78-0305	M3.5 x 7mm Pan Hd. Phil. Switch Scr.	(4)
25	44-76-0095	Cord Protector	(1)
26	22-64-3425	Power Cord	(1)

FIG.	PART NO.	DESCRIPTION OF PART	NO. REQ.
27	05-88-0030	M3 x 8.5mm Pan Hd. ST Screw T-10	(2)
28	22-18-2240	Carbon Brush Assembly (Set of 2)	(1)
29	31-50-0695	Motor Housing	(1)
30	06-82-2395	M2.6 x 10mm Pan Hd. ST Screw T-9	(2)
31	31-15-1005	Brush Cover Assembly (Set of 2)	(1)
31a	-----	Brush Cover - Left	(1)
31b	-----	Brush Cover - Right	(1)
32	31-44-0655	Rear Handle Set	(1)
32a	-----	Handle Halve - Left	(1)
32b	-----	Handle Halve - Right	(1)
33	22-56-0475	Terminal Connector Block	(1)
34	22-09-1825	PCB Assembly	(1)
35	05-88-1255	M4 x 22mm Pan Hd. ST T-20	(2)
37	06-82-1020	M4 x 14mm Pan Hd. ST T-20	(1)
38	18-07-0290	Field Assembly	(1)
38a	-----	Field Halve	(1)
38b	-----	Field Halve	(1)
39	42-28-0085	Rubber Block	(2)
40	-----	Baffle Foot	(1)
41	-----	Baffle	(1)
42	42-96-0016	Rubber Bearing Cap	(1)
43	16-10-0850	Armature Assembly	(1)
43a	02-04-2110	Ball Bearing	(1)
43b	-----	Armature	(1)
43c	45-88-0406	Washer	(1)
43d	31-86-0090	Plastic Disc	(1)
44	05-88-1280	M4 x 10mm Pan Hd. Mach. Screw T-20	(2)
45	44-86-0155	Bearing Retainer	(1)
★ 46	-----	Pinion	(1)
47	05-55-0620	M5 Hex Nut	(1)
50	14-46-6105	Flange with Ramps Assembly	(1)
52	42-14-0520	Baffle Assembly	(1)
56	44-86-0145	Bearing Retaining Plate Assembly	(1)
57	14-78-0525	Trigger Switch Assembly	(1)