



SERVICE PARTS LIST

BULLETIN NO.
54-38-2300

SPECIFY CATALOG NO. AND SERIAL NO. WHEN ORDERING PARTS		REVISED BULLETIN	DATE
4.5" COMPACT ANGLE GRINDER with PADDLE SWITCH with lock-on			June 2016
CAT. NO.	6141-30	STARTING SERIAL NUMBER	H38A
		WIRING INSTRUCTION See Reverse Side	

FIG.	PART NO.	DESCRIPTION OF PART	NO. REQ.
1	05-88-1650	M4 x 25mm Pan Hd. ST Screw T-20	(4)
2	42-62-0120	Side Handle Assembly	(1)
3	14-30-0082	Gear Case Assembly	(1)
3g	02-04-0620	Ball Bearing	(1)
4	34-40-0180	O-Ring	(1)
5	14-73-0460	Spindle Hub Assembly	(1)
5d	-----	Steel Pin	(1)

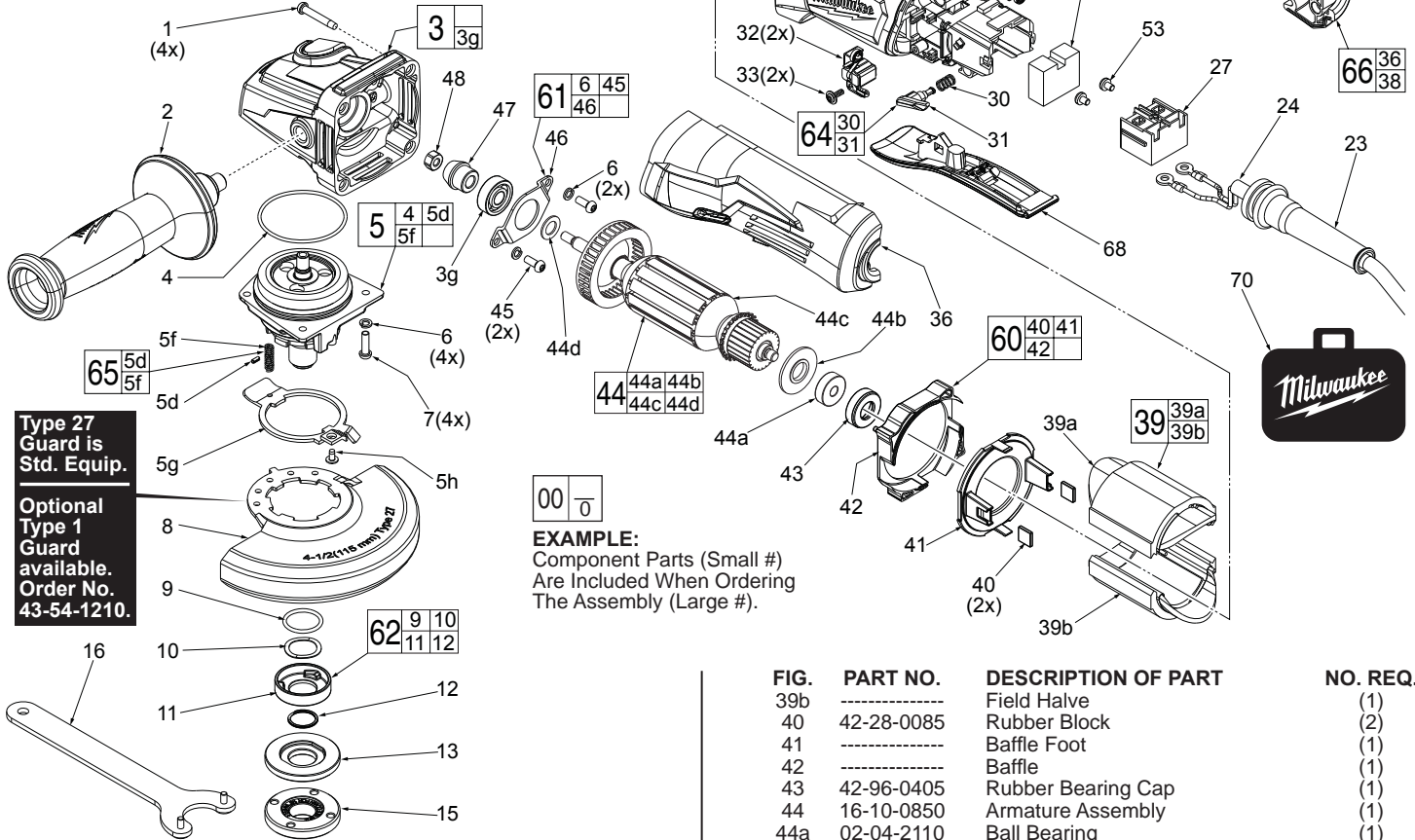

Type 27 Guard is Std. Equip.

Optional Type 1 Guard available. Order No. 43-54-1210.

EXAMPLE:
Component Parts (Small #) Are Included When Ordering The Assembly (Large #).

FIG.	PART NO.	DESCRIPTION OF PART	NO. REQ.
5f	-----	Spring	(1)
5g	44-20-0155	Guard Locking Tang	(1)
5h	05-81-0020	M3 x 5mm Pan Hd. ST T-8 Screw	(1)
6	05-90-0225	Spring Washer	(6)
7	05-88-1210	M4 x 14mm Pan Hd. Mach. T-20 Screw	(4)
8	43-54-1200	4.5" Type 27 Guard (Standard Equip.)	(1)
9	-----	O-Ring	(1)
10	-----	Wavey Spring	(1)
11	-----	Flange with Ramps	(1)
12	-----	Retaining Ring	(1)
13	43-34-0935	Inner Disc Flange	(1)
15	44-40-0035	Outer Flange Nut	(1)
16	49-96-7215	Spanner Wrench	(1)
21	05-88-1300	M4 x 28mm Pan Hd. ST T-20 Screw	(2)
22	05-88-1200	M4 x 16mm Pan Hd. ST T-20 Screw	(2)
23	44-76-0095	Cord Protector	(1)
24	22-64-2021	Power Cord	(1)
27	23-66-0185	On-Off Switch	(1)
30	-----	Spring	(1)
31	-----	Lock Button	(1)
32	22-18-2240	Carbon Brush Assembly (Set of 2)	(1)
33	05-88-0030	M3 x 8.5mm Pan Hd. ST T-10 Screw	(2)
34	31-50-6140	Motor Housing	(1)
35	23-16-0075	Foam Block	(1)
36	-----	Handle Support, Left Handle Halve	(1)
38	-----	Handle Cover, Right Handle Halve	(1)
39	18-07-0280	Field Assembly	(1)
39a	-----	Field Halve	(1)

FIG.	PART NO.	DESCRIPTION OF PART	NO. REQ.
39b	-----	Field Halve	(1)
40	42-28-0085	Rubber Block	(2)
41	-----	Baffle Foot	(1)
42	-----	Baffle	(1)
43	42-96-0405	Rubber Bearing Cap	(1)
44	16-10-0850	Armature Assembly	(1)
44a	02-04-2110	Ball Bearing	(1)
44b	31-86-0090	Plastic Disc	(1)
44c	-----	Armature	(1)
44d	45-88-0406	Washer	(1)
45	05-88-1280	M4 x 10mm Pan Hd. Mach. T-20 Screw	(2)
46	44-86-0155	Bearing Retainer	(1)
47	32-60-0301	Pinion	(1)
48	05-55-0620	M5 Hex Nut	(1)
49	12-20-6142	Service Nameplate (Not Shown)	(1)
50	10-20-6142	Warning Label (Not Shown)	(1)
53	05-78-0305	M3.5 x 7mm Pan Hd. Phillips Screw	(2)
60	42-14-0520	Baffle Assembly	(1)
61	44-86-0145	Bearing Retaining Plate Assembly	(1)
62	14-46-6105	Flange with Ramps Assembly	(1)
64	14-46-0231	Lock Button Kit	(1)
65	14-46-0241	Spring/Pin Kit	(1)
66	31-44-6100	Handle Set	(1)
68	31-92-0210	Paddle Trigger Assembly	(1)
70	42-55-6148	Canvas Tool Bag (Optional)	(1)

FIG. LUBRICATION
Use Type 'Y' Grease, No. 49-08-5270
3,5,47 When servicing the Gear Case Assembly (3), Pinion (47) or the Spindle Hub Assembly (5): 90-95% of the old grease must be removed prior to any new grease being added. Be sure that all gear teeth are heavily coated when reassembling.