



# SERVICE PARTS LIST

**BULLETIN NO.**  
54-38-2223

SPECIFY CATALOG NO. AND SERIAL NO. WHEN ORDERING PARTS		REVISED BULLETIN 54-38-2222	DATE Sep. 2016
<b>4.5" COMPACT ANGLE GRINDER with SLIDE SWITCH</b>			
CAT. NO.	6146-33	STARTING SERIAL NUMBER D04D	WIRING INSTRUCTION <b>See Reverse Side</b>

FIG.	PART NO.	DESCRIPTION OF PART	NO. REQ.
1	05-88-1650	M4 x 25mm Pan Hd. ST Screw T-20	(4)
2	42-62-0120	Side Handle Assembly	(1)
★ 3	14-30-1156	Gearcase Assembly	(1)
3a	-----	Spindle Lock Button	(1)
3b	-----	Spindle Lock Spring	(1)
3c	-----	Gearcase	(1)
3d	-----	O-Ring	(1)
3e	-----	Spindle Lock Pin	(1)
3f	-----	Needle Bearing	(1)
3g	02-04-0620	Ball Bearing	(1)
4	34-40-0560	O-Ring	(1)

★ = Part number change from previous service parts list.

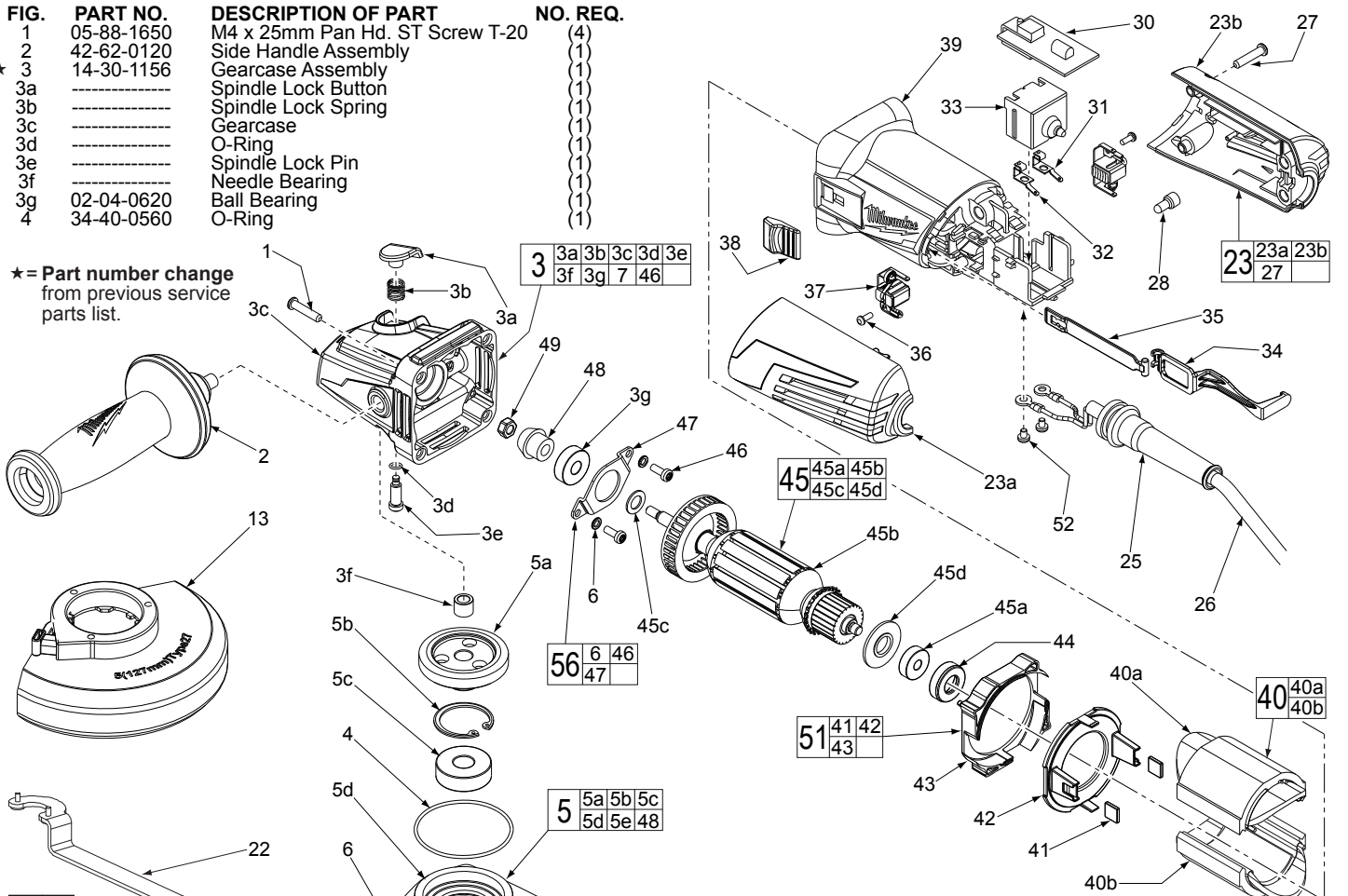

**EXAMPLE:**  
Component Parts (Small #)  
Are Included When Ordering  
The Assembly (Large #).

**\*LUBRICATION NOTE:**  
When servicing the Gears (5a & 48)  
or the Gearcase (3c), 90-95% of the  
old grease must be removed prior  
to new grease being added.

**FIG. LUBRICATION\***  
5a,48 Type "Y" Grease, No. 49-08-5270,  
Must Be Applied To All Gear Teeth.

5	14-46-0417	5/8" Spindle Hub Kit	(1)
5a	-----	Spiral Bevel Gear	(1)
5b	-----	Retaining Ring	(1)
5c	-----	Ball Bearing	(1)
5d	-----	Spindle Hub	(1)
5e	-----	5/8" Spindle	(1)
6	05-90-0225	Spring Washer	(6)
★ 7	05-78-5316	M4 x 14mm Pan Hd. Tapt. Screw T-20	(4)
13	14-32-0210	4.5" Type 27 Guard Assembly (Shown)	(1)
13	43-54-0920	4.5" Type 1 Guard Assy. (Not Shown)	(1)
15	-----	O-Ring	(1)
16	-----	Wavy Spring	(1)
17	-----	Flange with Ramps	(1)
18	-----	Retaining Ring	(1)
19	43-34-0935	Inner Disc Flange	(1)
21	44-40-0035	Outer Flange Nut	(1)
22	49-96-7205	Spanner Wrench	(1)
23	14-34-6105	Rear Handle Set	(1)
23a	-----	Left Handle Halve	(1)
23b	-----	Right Handle Halve	(1)

FIG.	PART NO.	DESCRIPTION OF PART	NO. REQ.
25	44-76-0095	Cord Protector	(1)
26	22-64-3430	Power Cord	(1)
27	05-88-1300	M4 x 28mm Pan Hd. ST Screw T-20	(4)
28	22-56-0150	Close End Connector	(1)
30	22-09-1820	PCB Assembly	(1)
31	23-74-1620	Terminal	(1)
32	23-74-1615	Terminal	(1)
33	23-66-2665	On-Off Switch	(1)
34	31-84-0080	Slide Pole - Back	(1)
35	31-84-0085	Slide Pole - Front	(1)
36	05-88-0030	M3 x 8.5mm Pan Hd. ST Screw T-10	(2)
37	22-18-2240	Carbon Brush Assembly (Set of 2)	(1)
38	31-89-0245	Slide Switch Button	(1)
39	31-50-0676	Motor Housing	(1)
40	18-07-0275	Field Assembly	(1)
40a	-----	Field Halve	(1)
40b	-----	Field Halve	(1)
41	42-28-0085	Rubber Block	(2)
42	-----	Baffle Foot	(1)
43	-----	Baffle	(1)
44	42-96-0017	Rubber Bearing Cap	(1)
45	16-10-0850	Armature Assembly	(1)
45a	02-04-2110	Ball Bearing	(1)
45b	-----	Armature	(1)
45c	45-88-0406	Washer	(1)
45d	31-86-0090	Plastic Disc	(1)
★ 46	05-78-0105	M4 x 10mm Pan Hd. Tapt. Screw T-20	(2)
47	44-86-0155	Bearing Retainer	(1)
48	-----	Pinion	(1)
49	05-55-0620	M5 Hex Nut	(1)
50	14-46-6105	Flange with Ramps Assembly	(1)
51	42-14-0520	Baffle Assembly	(1)
52	05-78-0305	M3.5 x 7mm Pan Hd. Phil. Switch Scr.	(2)
53	12-20-1560	Service Nameplate (Not Shown)	(1)
56	44-86-0145	Bearing Retaining Plate Assembly	(1)