



SERVICE PARTS LIST

BULLETIN NO.
54-42-6303

SPECIFY CATALOG NO. AND SERIAL NO. WHEN ORDERING PARTS		REVISED BULLETIN	DATE
O.E.M. POWER UNIT		54-42-6302	Sept. 2013
CATALOG NO.	6792-20	WIRING INSTRUCTION	
STARTING SERIAL NO.	181D	See Pages 2 & 3	

EXAMPLE:
Component Parts (Small #) Are Included
When Ordering The Assembly (Large #).

★=Part number change from
previous service parts list.

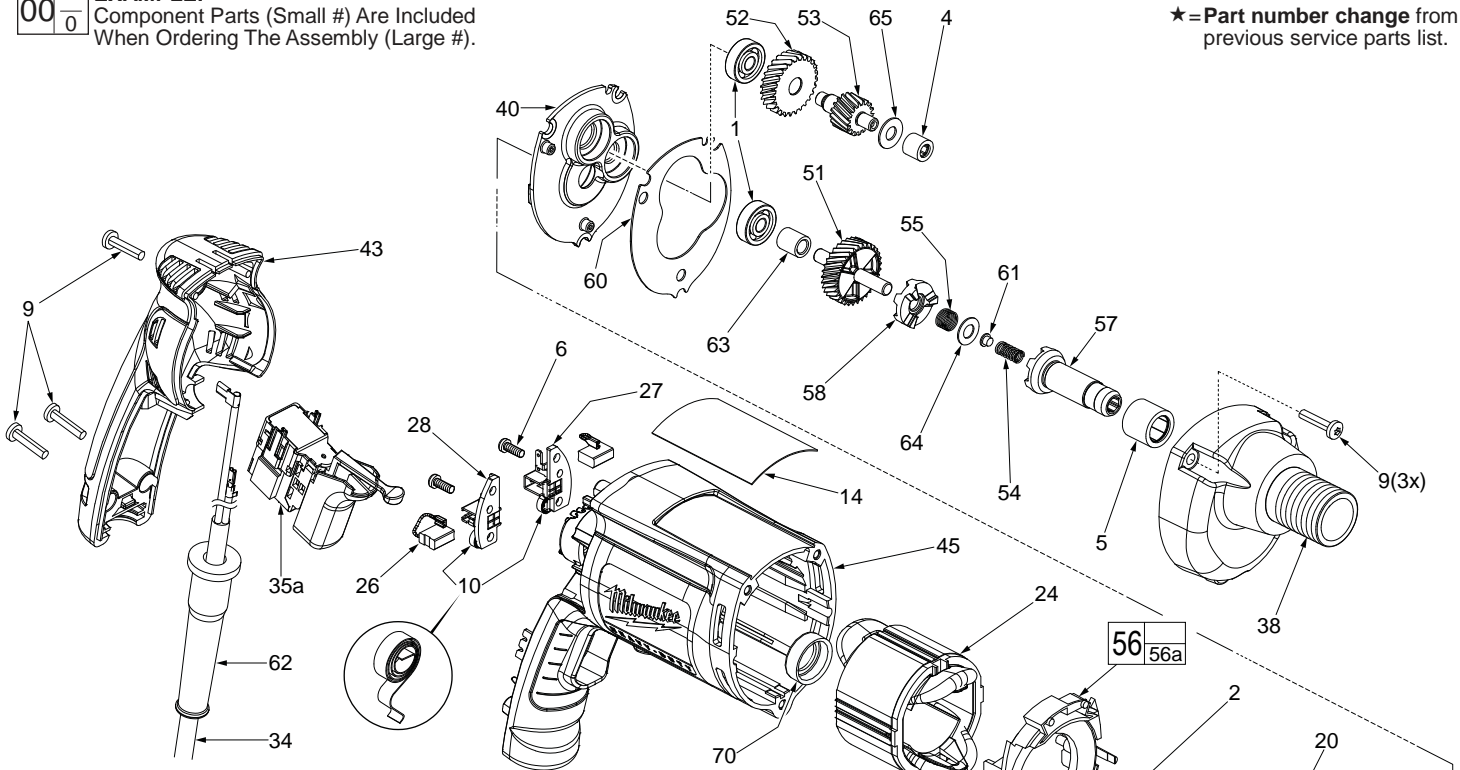

FIG.	PART NO.	DESCRIPTION OF PART	NO. REQ.
1	02-04-0640	Ball Bearing	(2)
2	02-04-0645	Ball Bearing	(1)
3	02-04-0852	Ball Bearing	(1)
4	02-50-2400	Needle Bearing	(1)
5	02-50-3245	Needle Bearing	(1)
6	05-88-1610	M3.5 x 10 Pan Hd. Plastite T-10	(2)
9	06-82-7275	7-18 x 3/4" Slotted Plastite Torx T-20	(6)
10	23-52-1610	Brush Spring	(2)
14	12-99-2665	Service Nameplate	(1)
20	16-10-2205	Armature	(1)
24	18-07-7210	Field	(1)
26	22-18-1310	Brush Assembly	(2)
27	22-20-0090	Left Brush Holder	(1)
28	22-20-0095	Right Brush Holder	(1)
34	22-64-6510	Cord Assembly	(1)
35a	23-66-2605	Switch (Defond) See page 2 wiring	(1)
35b	23-66-2585	Switch (Marquardt) See page 3 wiring	(1)
38	28-14-2395	O.E.M. Gearcase	(1)
40	28-28-2315	Diaphragm	(1)
43	31-15-2010	Handle Halve	(1)
★ 45	31-50-0526	Motor Housing	(1)
51	32-10-0525	Clutch Gear Assembly	(1)
52	32-40-0100	Intermediate Gear	(1)
53	36-66-0120	Intermediate Shaft	(1)
54	40-50-0095	Separator Spring	(1)
55	40-50-8515	Bias Spring Baffle	(1)
56	42-14-0460	Assembly Slug	(1)
56a	45-30-0030	(Not Shown)	(2)
57	42-66-0715	Clutch Chuck Assembly	(1)
58	42-70-0310	Drive Clutch	(1)
59	42-70-5280	Belt Clip	(1)
60	43-44-0985	Gasket	(1)
61	44-60-0505	Thrust Pin	(1)
62	44-76-0210	Cord Protector	(1)
63	45-36-1280	Spacer	(1)
64	45-88-0555	Clutch Thrust Washer	(1)
65	45-88-7990	Thrust Washer	(1)
★ 70	43-86-0125	Bearing Cup	(1)
	23-94-0490	White Leadwire Assy. (See pages 2 & 3)	(1)
	23-94-0495	Red Leadwire Assy. (See pages 2 & 3)	(1)
	31-53-0205	Lock Button Plug (Not Shown)	(1)

LUBRICATION (Type "Y" Grease, No. 49-08-5270)

- Fill the 3 enlarged clutch pockets of the clutch gear assembly (51) with .5 gm. (.02 oz.) grease.
- Apply the same amount of grease in the bias spring (55).
- Apply in total .5 gm. (.02 oz.) grease to the clutch thrust washer (64), thrust pin (61) and separator spring (54).
- Place 7.7 gm. (.27 oz.) of grease at the armature pin location in the gearcase (38) and fill to slightly above the next higher gearcase level.
- Apply a light film of grease to the lead chamfer of the clutch chuck (57) prior to assembly.

Before assembly, lightly coat all press fit areas with lightweight spindle oil.

FIG. NOTES:

- 5 Needle bearing to have it's seal toward the front of the tool. Needle bearing to be pressed .133/.143 under flush.

MILWAUKEE ELECTRIC TOOL CORPORATION
13135 W. LISBON RD., BROOKFIELD, WI 53005