

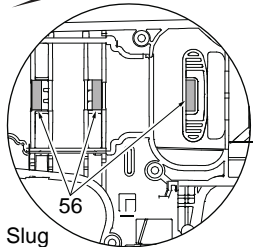

SERVICE PARTS LIST

BULLETIN NO.
54-26-1728

SPECIFY CATALOG NO. AND SERIAL NO. WHEN ORDERING PARTS		REVISED BULLETIN	DATE
1/2" D.I. IMPACT WRENCH		54-26-1727	July 2013
CATALOG NO. 9071-20	STARTING SERIAL NO. 230D	WIRING INSTRUCTION See Page 2	



Slug placement is for both handle halves.

Replace the Gasket (13) whenever the tool is opened for servicing.

EXAMPLE:
Component Parts (Small #) Are Included When Ordering The Assembly (Large #).

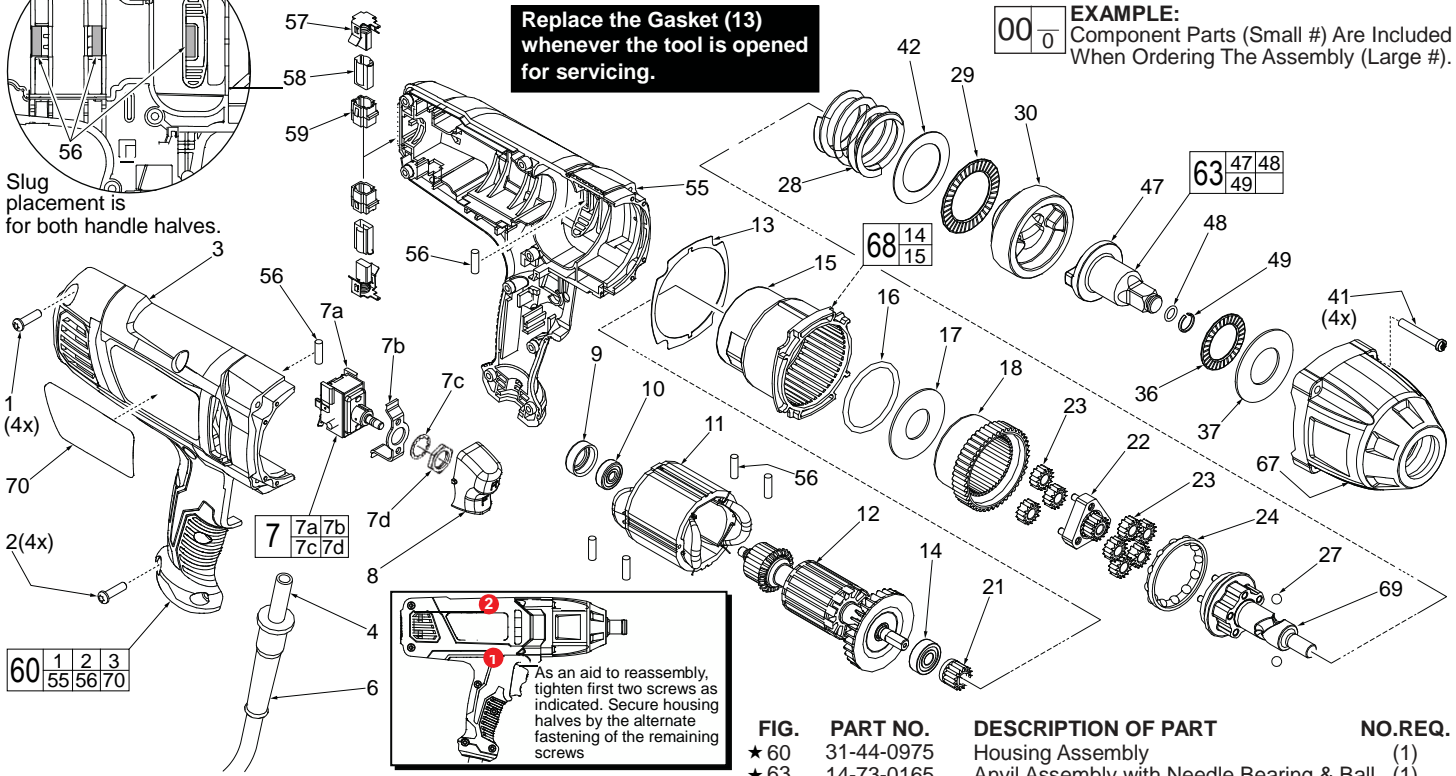

FIG.	PART NO.	DESCRIPTION OF PART	NO.REQ.
1	06-95-6290	M5 x 18mm Pan Hd. Plast. T-20 Screw	(4)
★ 2	06-95-6215	M5 x 14mm Pan Hd. Plast. T-20 Screw	(4)
★ 3	-----	Handle Cover (Right Side)	(1)
★ 4	22-64-0975	Power Cord	(1)
6	44-76-0210	Cord Protector	(1)
7	23-66-1306	Switch Assembly	(1)
7a	-----	Switch	(1)
7b	-----	Switch Bracket	(1)
7c	-----	Supplied with Switch	(1)
7d	-----	Supplied with Switch	(1)
8	31-92-0060	Rocker Trigger	(1)
9	42-96-0015	Bearing Cup	(1)
10	02-04-0645	Ball Bearing	(1)
★ 11	18-07-2280	Service Field	(1)
12	16-10-2275	Service Armature	(1)
★ 13	43-44-0992	Gasket	(1)
14	02-04-0852	Ball Bearing	(1)
15	28-14-0175	Gearcase	(1)
16	34-40-0070	O-Ring	(1)
17	45-88-3250	Washer	(1)
18	32-65-0005	Gear Ring	(1)
21	32-60-0150	Sun Gear (Pinion)	(1)
22	32-60-0175	Sun Gear (Carrier)	(1)
23	32-62-0215	Planet Gear	(8)
24	02-40-0050	Angular Contact Bearing	(1)
27	02-02-0250	1/4" Steel Ball	(2)
28	40-50-0241	Spring	(1)
29	02-80-0200	Thrust Needle Bearing	(1)
30	44-82-0205	Ram	(1)
36	02-80-3256	Thrust Bearing	(1)
37	45-88-1575	Washer	(1)
41	05-88-5988	M5 x 35mm Pan Hd. T-20 Screw	(4)
42	45-88-0535	Washer	(1)
47	-----	1/2" Square Anvil with bearing and ball	(1)
48	34-40-0900	O-Ring	(1)
49	44-90-4530	Friction Ring	(1)
53	23-94-9061	Wire Assembly-White (See page two)	(1)
54	23-94-9062	Wire Assembly-Blue (See page two)	(1)
★ 55	-----	Handle Support (Left Side)	(1)
★ 56	45-30-0025	Rubber Slug	(6)
57	22-18-0040	Carbon Brush Assembly	(2)
58	22-20-0110	Brush Tube	(2)
59	22-20-0465	Brush Tube Holder	(2)

FIG.	PART NO.	DESCRIPTION OF PART	NO.REQ.
★ 60	31-44-0975	Housing Assembly	(1)
★ 63	14-73-0165	Anvil Assembly with Needle Bearing & Ball	(1)
★ 67	14-38-0130	Front Housing Assembly Contains Bushing and two O-Rings	(1)
★ 68	28-14-0005	Gearcase Assembly	(1)
69	14-73-0300	Cam Shaft Assembly	(1)
★ 70	12-20-9090	Service Nameplate	(1)

- FIG. NOTES:**
- 10 Orient bearing seal (black side) toward the commutator.
 - 41 Torque to 37-42 in./lbs (42-48 kg/cm).
 - 1 Torque to 20-25 in./lbs (23-29 kg/cm). (Longer handle screw).
 - 2 Torque to 17-22 in./lbs (20-25 kg/cm). (Shorter handle screw).
 - 57 At the time of brush replacement, the tool should be relubricated with Type "Z" Grease, No.49-08-7655.
- When servicing, remove 90-95% of the existing grease prior to installing Type "Z". Original grease may be similar in color but not compatible with "Z".**

- FIG. LUBRICATION (Type "Z" Grease, No.49-08-7655):**
- 18,30, 67,69 Lightly coat with grease the Ring Gear (18) and the bearing races of the Camshaft Planet Carrier (69), the back bearing surface of the Ram (30) and the I.D. the Bushing in the Front Housing Assembly (67).
 - 47 Place a dab of grease inside the rear hole of the Anvil (47).
 - 22,23 Fill with grease the center of the five Planet Gears (23) on the Camshaft Assembly (69). Fill the center of the three Planet Gears (23) on the Sun Gear (22).
 - 30 Place approximately 1/2 oz. grease in the front cavity of the Ram.
 - 69 Place approximately 1/2 oz. grease on the Camshaft (69) inside the Spring (28).