



# SERVICE PARTS LIST

**BULLETIN NO.**  
**54-26-1751**

SPECIFY CATALOG NO. AND SERIAL NO. WHEN ORDERING PARTS		REVISED BULLETIN	DATE
<b>VARIABLE SPEED 1/2" D.I. IMPACT WRENCH</b>		54-26-1750	Dec. 2016
CATALOG NO. <b>9072-20</b>	STARTING SERIAL NO. <b>238B</b>	WIRING INSTRUCTION <b>58-01-1821</b>	

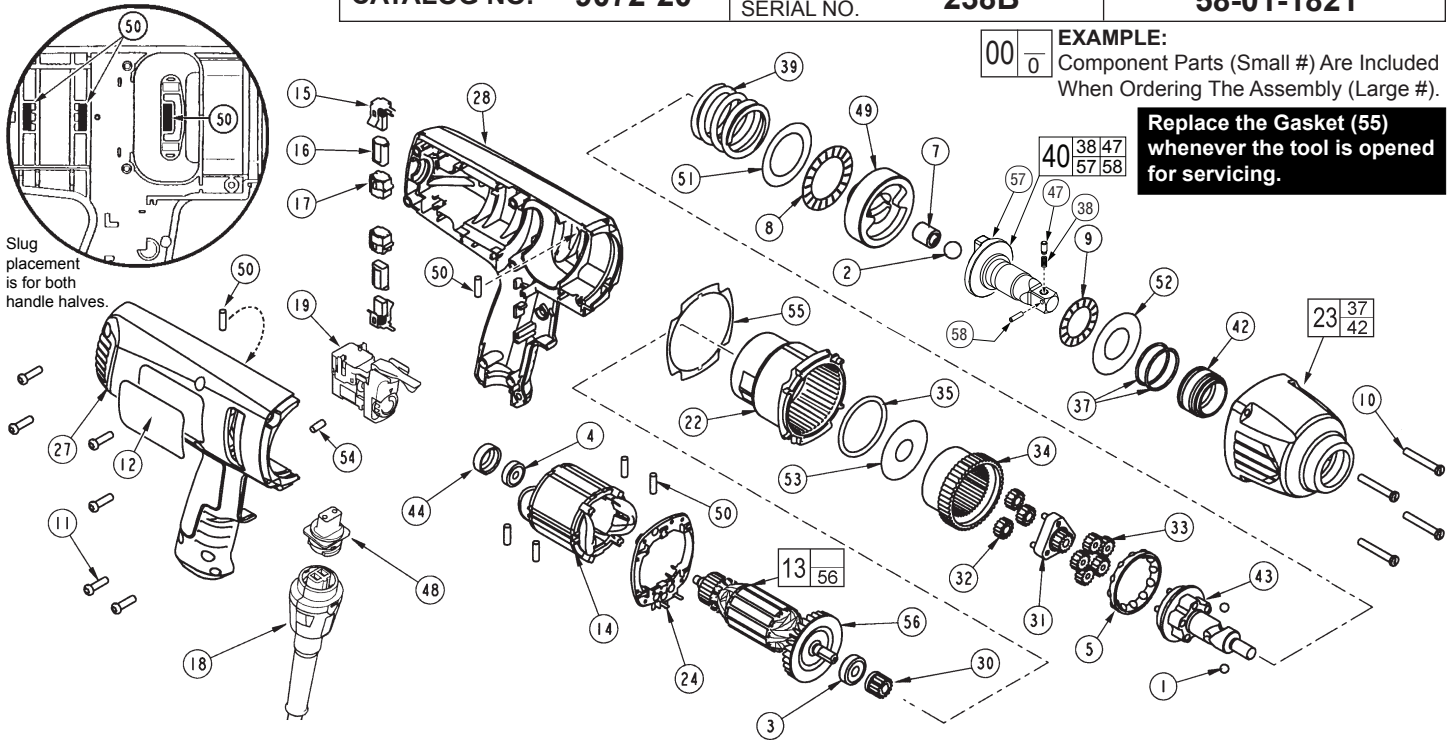

FIG.	PART NO.	DESCRIPTION OF PART	NO.REQ.
1	02-02-0250	1/4" Ball	(2)
2	-----	1/2" Ball	(1)
3	02-04-0852	Ball Bearing	(1)
4	02-04-0645	Ball Bearing	(1)
5	02-40-0050	Angular Contact Bearing	(1)
7	-----	Drawn Cup Bearing	(1)
8	02-80-0200	Thrust Bearing	(1)
9	02-80-3256	Thrust Bearing	(1)
10	05-88-5988	K50 x 35mm Screw	(4)
11	06-95-6290	M5 x 2.24 x 18 Plastite Screw	(6)
12	12-20-9070	Service Nameplate	(1)
13	16-10-2275	Armature	(1)
14	18-07-2275	Field	(1)
15	22-18-0040	Brush Assembly	(1)
16	22-20-0110	Brush Tube	(2)
17	22-20-0465	Brush Tube Holder	(2)
18	48-76-5010	Quik-Lok Cord Set	(1)
19	23-66-2765	Switch	(1)
22	28-14-0175	Gearcase	(1)
23	14-38-0100	Front Housing Assembly	(1)
24	31-15-2045	Field Connector	(1)
27	31-44-2176	Right Handle	(1)
28	31-44-2181	Left Handle	(1)
30	32-60-0150	Sun Gear	(1)
31	32-60-0175	Sun Gear	(1)
32	32-62-0215	Planet Gear	(3)
33	32-62-0215	Planet Gear	(5)
34	32-65-0005	Ring Gear	(1)
35	34-40-0070	O-Ring	(1)
37	-----	O-Ring	(2)
38	40-50-0895	Detent Spring	(1)
39	40-50-0241	Spring	(1)
40	14-73-0455	Anvil Assembly	(1)
42	-----	Bushing	(1)
43	14-73-0300	Cam Shaft Assembly	(1)
44	42-96-0015	Bearing Cup	(1)
47	44-60-0597	Detent Pin	(1)
48	22-56-9070	Blade Housing Assembly	(1)
49	44-82-0205	Ram	(1)
50	45-30-0025	Rubber Slug	(6)

FIG.	PART NO.	DESCRIPTION OF PART	NO.REQ.
51	45-88-0535	Washer	(1)
52	45-88-1575	Washer	(1)
53	45-88-3250	Washer	(1)
54	45-30-0021	Rubber Slug	(1)
55	43-44-0991	Gasket	(1)
56	22-84-0375	Fan	(1)
57	-----	1/2" Square Anvil	(1)
58	44-60-0465	Pivot Pin	(1)

**FIG. NOTES:**

- 4 Orient bearing seal (black side) toward the commutator.
- 10 Torque to 45-50 in./lbs.
- 11 Torque to 25-30 in./lbs.
- 16 At the time of brush replacement, the tool should be relubricated with Type "J" Grease, No.49-08-4220.
- FIG. LUBRICATION (Type "J" Grease, No.49-08-4220):**
- 23,34,42, 43,49 Lightly coat with grease the Ring Gear (34) and the bearing races of the Camshaft Planet Carrier (43), the back bearing surface of the Ram (49) and the I.D. the Front Housing Bushing (42).
- 7,40 Place a dab of grease in the Needle Bearing (7) inside the Anvil (40).
- 31,32,33,43 Fill with grease the center of the five Planet Gears (33) on the Camshaft Assembly (43). Fill the center of the three Planet Gears (32) on the Sun Gear (31).
- 49 Place approximately 1/2 oz. of grease in the front cavity of the Ram.
- 43 Place approximately 1/2 oz. grease on the Camshaft (43) inside the Spring (39).