

SPECIFY CATALOG NO. AND SERIAL NO. WHEN ORDERING PARTS		REVISED BULLETIN 54-24-0680	DATE Jan. 2014
1/2" HAMMER-DRILL			
CATALOG NO.	5378-20	STARTING SERIAL NO.	897H
		WIRING INSTRUCTION SEE PAGE THREE	

EXAMPLE:
00 0 Component Parts (Small #)
Are Included When Ordering
The Assembly (Large #).

★ = Part number change from
previous service parts list.

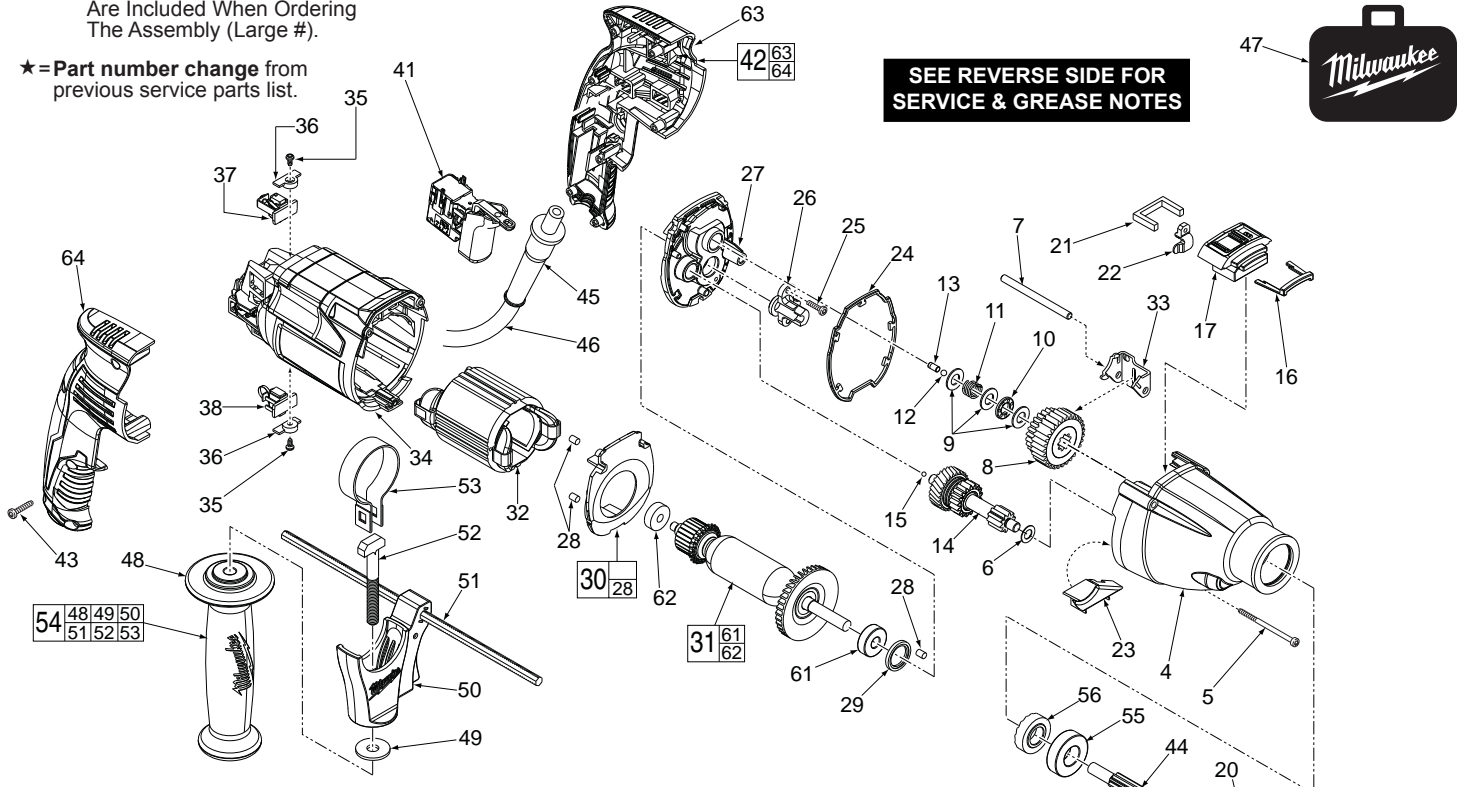

FIG.	PART NO.	DESCRIPTION OF PART	NO. REQ.
1	05-88-1500	M6 x 27 Chuck Screw	(1)
2	48-66-3280	Chuck Key	(1)
3	48-66-1355	Chuck (Incl. Chuck Key)	(1)
4	28-14-5382	Gearcase Assembly (Incl. Needle Bearing, Fixed Ratchet and Shifting Assy.)	(1)
5	06-81-5380	M4 x 52 ST T-20 Screw	(3)
6	45-88-5381	Washer	(1)
7	44-94-5380	Pin	(1)
8	14-29-5378	1st and 2nd Spindle Gear Assembly	(1)
9	45-88-5378	Washer	(3)
10	02-80-5380	Thrust Bearing	(1)
11	40-50-5380	Spring	(1)
12	02-02-5380	Ball	(1)
13	44-60-5381	Pin	(1)
14	14-29-5379	Gear Shaft Assembly	(1)
15	02-02-0165	Ball	(1)
16	43-44-5381	Rubber Seal	(1)
17	14-34-5382	Selector Housing Assembly	(1)
18	34-80-5380	Retaining Ring	(1)
19	43-44-5380	Seal	(1)
20	45-88-5380	Washer	(1)
21	43-44-5378	Felt Seal	(1)
22	43-96-5380	Speed Selector Key	(1)
23	44-66-5381	Grease Plate	(1)
24	43-44-5379	Gasket	(1)
25	05-88-5380	M3.5 x 12 T-10 Screw	(2)
26	42-36-5378	Pinion Support	(1)
27	28-14-5378	Diaphragm Assy. (Incl. Washer & Bearings)	(1)
28	42-34-5380	Rubber Slug	(3)
29	43-44-5377	Seal Ring	(1)
30	14-34-5383	Baffle Assembly	(1)
31	16-07-5376	Service Armature Assembly	(1)
32	18-07-5376	Service Field	(1)
33	44-66-5378	Shifting Clip	(1)
34	31-50-5378	Motor Housing	(1)
35	06-81-5381	M3 x 6 Pan Hd. Phillips Screw	(2)
36	44-66-5379	Brush Holder Retaining Plate	(2)
37	22-22-5380	Brush Assy.-w/pop-off (Incl. Spring & Holder)	(1)
38	22-22-5381	Brush Assy.-regular (Incl. Spring & Holder)	(1)

Apply a drop of Blue Loctite®
thread locking adhesive to chuck
screw (1) prior to installing onto
spindle (44).

FIG.	PART NO.	DESCRIPTION OF PART	NO. REQ.
★ 41	23-66-5381	Switch	(1)
42	14-34-5378	Rear Handle Assembly	(1)
43	05-88-1200	M4 x 16 Pan Hd. T-20 Screw	(7)
44	38-50-5380	Spindle Shaft	(1)
45	44-76-0210	Cord Protector	(1)
★ 46	22-64-5378	Cord Set	(1)
47	42-55-5378	Carrying Case	(1)
48	31-05-5379	Side Handle	(1)
49	45-88-5377	Washer	(1)
50	14-34-5374	Side Handle Carrier Assembly	(1)
51	44-94-5381	Depth Gauge	(1)
52	05-81-5378	M8 x 53 Bolt	(1)
53	40-50-5370	Side Handle Clamping Band	(1)
54	14-34-5379	Side Handle Assembly	(1)
55	02-04-5380	Ball Bearing	(1)
56	44-84-5380	Rotating Ratchet	(1)
61	02-04-5381	Ball Bearing	(1)
62	02-04-5382	Ball Bearing	(1)
63	-----	Left Handle Halve	(1)
64	-----	Right Handle Halve	(1)
	12-20-5378	Service Nameplate Kit (Not Shown)	(1)
	48-66-4040	Chuck Key Holder (Not Shown)	(1)
	23-94-5381	Red Brush Leadwire Assy. (Not Shown)	(1)
	23-94-5379	Black Brush Leadwire Assy. (Not Shown)	(1)