



SERVICE PARTS LIST

BULLETIN NO.
54-06-2630

SPECIFY CATALOG NO. AND SERIAL NO. WHEN ORDERING PARTS			REVISED BULLETIN	DATE
M18™ Grease Gun				Feb. 2013
CATALOG NO.	2646-20	STARTING SERIAL NO.	WIRING INSTRUCTION	
		E98A	See Reverse Side	

FIG.	PART NO.	DESCRIPTION OF PART	NO. REQ.
23	45-98-0005	Yoke	(1)
24	31-15-0038	Yoke Cover	(1)
25	05-81-2000	M5 x 0.8 x 10mm Pan Hd. T-25 Screw	(2)
26	05-85-0700	Hex Socket Screw	(1)
27	05-88-1300	M4 x 28mm Pan Hd. Plastite T-20 Screw	(4)

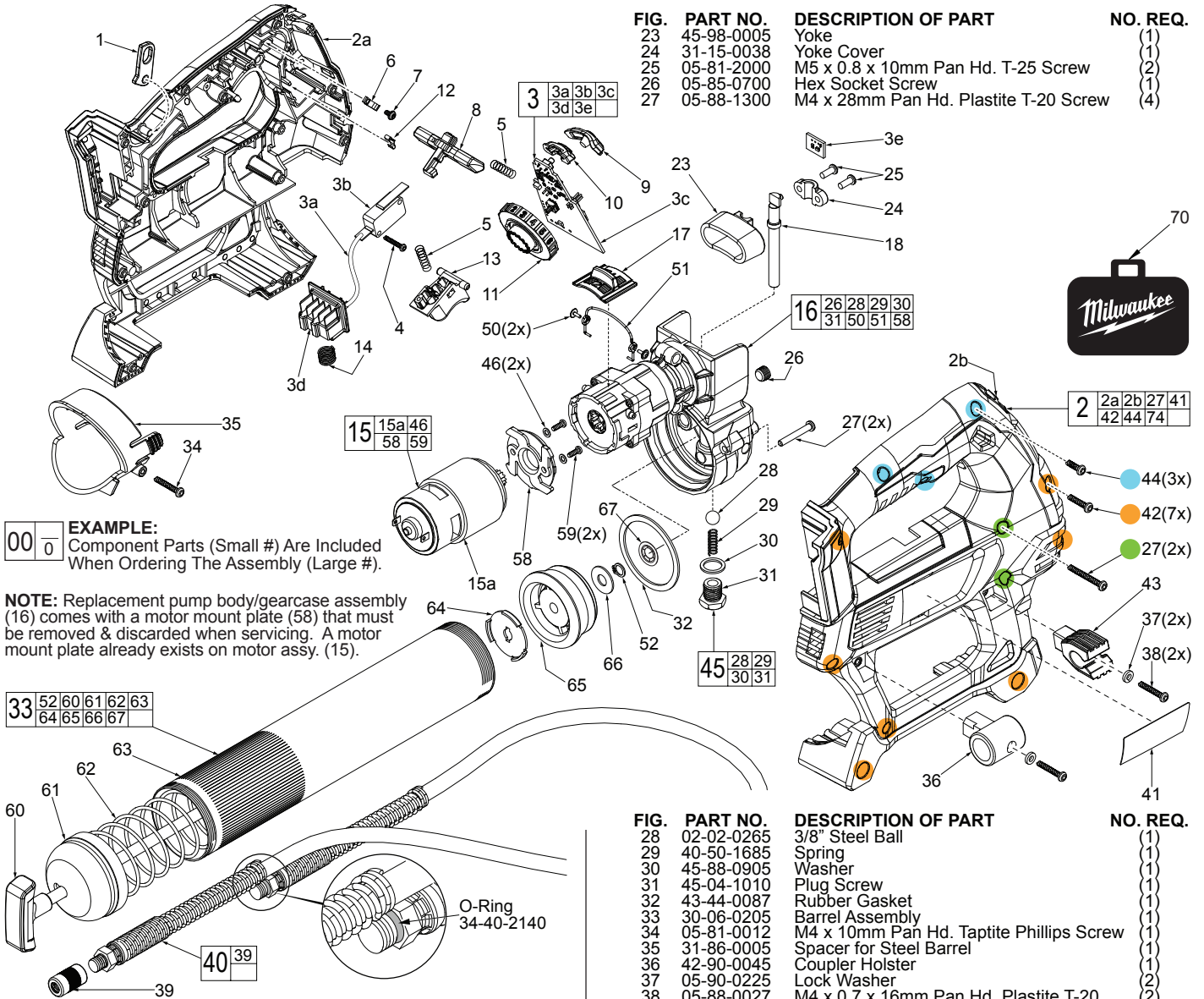

EXAMPLE:
Component Parts (Small #) Are Included When Ordering The Assembly (Large #).

NOTE: Replacement pump body/gearcase assembly (16) comes with a motor mount plate (58) that must be removed & discarded when servicing. A motor mount plate already exists on motor assy. (15).

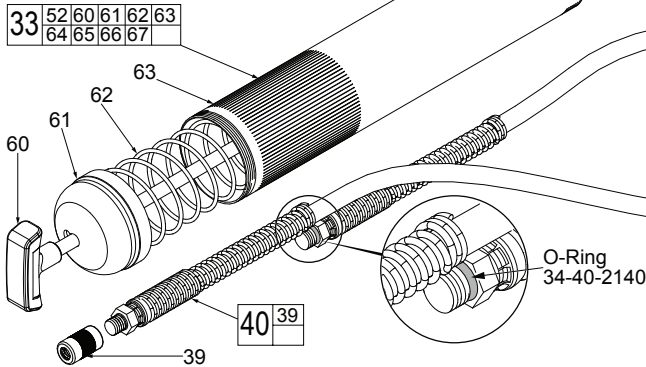

FIG.	PART NO.	DESCRIPTION OF PART	NO. REQ.
1	43-72-0022	Tool Holder/Hanger	(1)
2	31-50-0272	Housing Kit	(1)
2a	-----	Handle Support with Hanger Pin	(1)
2b	-----	Handle Cover	(1)
3	23-66-1145	Switch/Electronics Assembly	(1)
3a	-----	Red Leadwire	(1)
3b	23-66-2885	On-Off Switch	(1)
3c	-----	PCB Assembly	(1)
3d	-----	Battery Connector Block	(1)
3e	-----	Hall Sensor	(1)
4	06-82-2385	M2.6 x 14mm Pan Hd. Plastite T-8 Screw	(1)
5	40-50-0890	Spring	(2)
6	40-50-0232	Plate Spring	(1)
7	05-88-0030	M3 x 8.5mm Pan Hd. ST T-10 Screw	(1)
8	42-42-0037	Lock On-Off Shuttle	(1)
9	44-06-0177	Clear LED Cover	(1)
10	42-42-1045	LED Button Cover	(1)
11	43-98-0555	Counter Dial	(1)
12	40-50-0253	Plate Spring	(1)
13	45-72-0088	Switch Trigger	(1)
14	40-50-1090	Compression Spring	(1)
15	23-30-0770	Motor Assembly	(1)
15a	-----	Motor	(1)
16	44-70-0112	Pump Body/Gearcase Assembly	(1)
16a	-----	Pump Body/Gearcase	(1)
17	45-24-0033	Speed Selector Button	(1)
18	44-62-0105	Piston Assembly with Magnet	(1)

FIG.	PART NO.	DESCRIPTION OF PART	NO. REQ.
28	02-02-0265	3/8" Steel Ball	(1)
29	40-50-1685	Spring	(1)
30	45-88-0905	Washer	(1)
31	45-04-1010	Plug Screw	(1)
32	43-44-0087	Rubber Gasket	(1)
33	30-06-0205	Barrel Assembly	(1)
34	05-81-0012	M4 x 10mm Pan Hd. Tapitite Phillips Screw	(1)
35	31-86-0005	Spacer for Steel Barrel	(1)
36	42-90-0045	Coupler Holster	(1)
37	05-90-0225	Lock Washer	(2)
38	05-88-0027	M4 x 0.7 x 16mm Pan Hd. Plastite T-20	(2)
39	42-90-0065	Coupler Assembly (Accessory)	(1)
40	14-37-0110	Grease Hose Assembly	(1)
41	12-20-2646	Service Nameplate	(1)
42	05-88-1250	M4 x 20mm Pan Hd. T-20 Screw	(7)
43	43-75-0200	Grease Hose Holster	(1)
44	05-88-1200	M4 x 16mm Pan Hd. T-20 Screw	(3)
45	45-04-1030	Plug Screw Kit	(1)
46	-----	Washer	(2)
50	05-81-0542	M2.3 x 6mm ST Philips Hd. Screw	(2)
51	44-10-0030	Speed Selector Wire Link	(1)
52	44-86-1380	Retaining Ring	(1)
58	-----	Motor Mount Plate	(1)
59	-----	M4 x 8mm Pan Hd. Philips Screw	(2)
60	44-94-0075	Plunger Rod with Handle	(1)
61	-----	Barrel Tube Cover	(1)
62	-----	Barrel Spring	(1)
63	-----	Barrel	(1)
64	44-66-1525	Steel Plate	(1)
65	45-06-0890	Rubber Seal	(1)
66	45-88-2030	Washer	(1)
67	44-86-1400	Self-Locking Retaining Ring	(1)
70	42-55-2646	Carrying Case	(1)
75	45-56-0125	Shoulder Strap (Not Shown)	(1)
76	49-16-2438	Right Angle Adaptor (Not Shown)	(1)

MILWAUKEE ELECTRIC TOOL CORPORATION
13135 W. Lisbon Road, Brookfield, WI 53005
Drwg. 2