

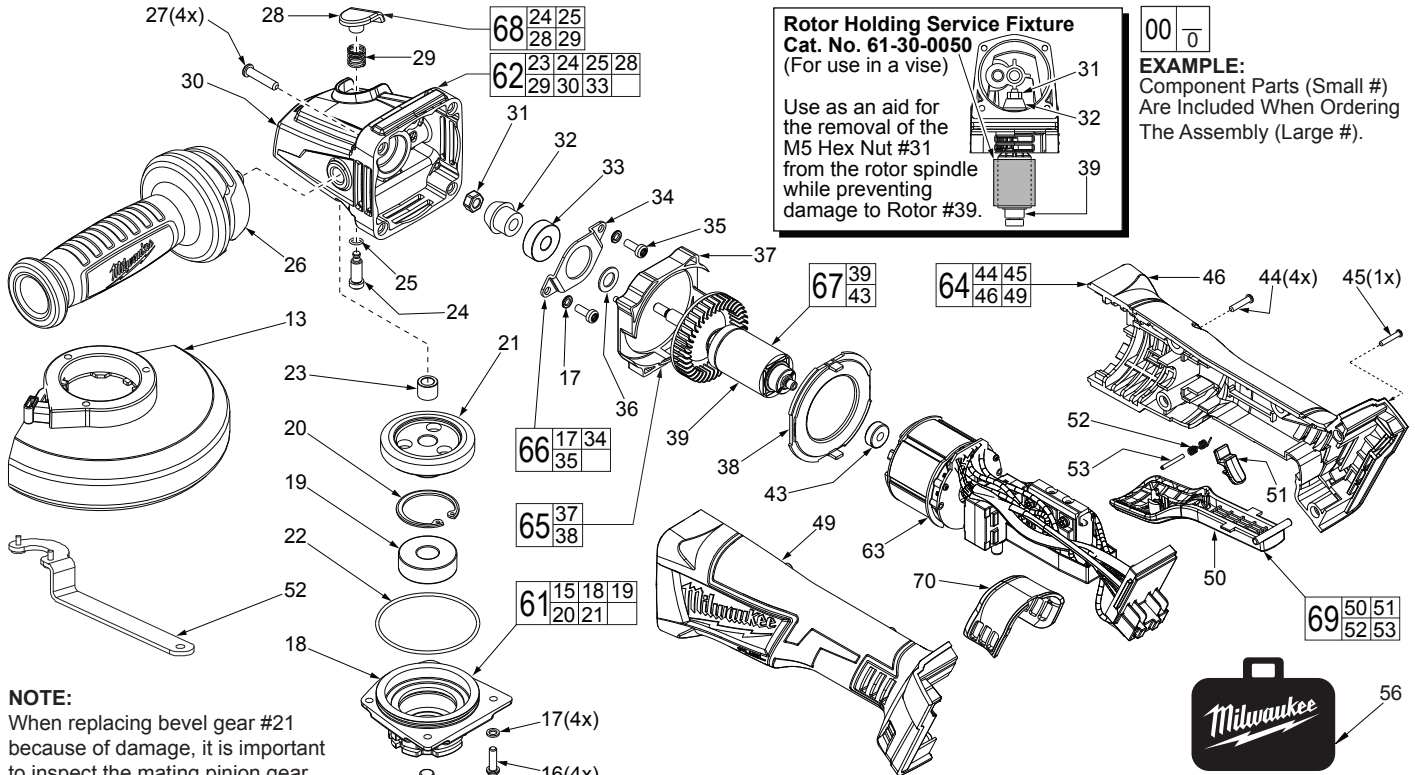

SERVICE PARTS LIST

BULLETIN NO.
54-38-7010

SPECIFY CATALOG NO. AND SERIAL NO. WHEN ORDERING PARTS		REVISED BULLETIN	DATE
M18 FUEL™ Angle Grinder with Paddle Switch & Lock-Off			July 2014
CATALOG NO. 2780-20	STARTING SERIAL NO. F33A	WIRING INSTRUCTION SEE PAGE 2	



NOTE:
When replacing bevel gear #21 because of damage, it is important to inspect the mating pinion gear #32 for damage also. It is recommended that gears be replaced in sets.

***LUBRICATION NOTE:**
When servicing the Gears (21 & 32) or the Gearcase (30), 90-95% of the old grease must be removed prior to new grease being added.

FIG. LUBRICATION*
21,32 Type "Y" Grease, No. 49-08-5270, Must Be Applied To All Gear Teeth.

FIG.	PART NO.	DESCRIPTION OF PART	NO. REQ.
1	44-40-0035	Flange Nut	1
3	43-34-0935	Flange Disc	1
4	-----	Flange with Ramps	1
5	-----	Retaining Ring	1
6	-----	Wave Spring	1
7	-----	O-Ring	1
13	14-32-0215	5" Type 27 Guard Assy. (Shown) (Standard)	1
13	43-54-0925	5" Type 1 Guard Assy. (Not Shown) (Standard)	1
13	14-32-0210	4.5" Type 27 Guard Assy. (Optional)	1
13	43-54-0920	4.5" Type 1 Guard Assy. (Optional)	1
15	-----	Output Shaft	1
16	05-88-1210	M4 x 14mm Pan Hd. T-20 Screw	4
17	05-90-0225	Spring Washer	6
18	-----	Spindle Hub	1
19	-----	Ball Bearing	1
20	-----	Retaining Ring	1
21	-----	Bevel Gear	1
22	34-40-0180	O-Ring	1
23	-----	Needle Bearing	1
24	-----	Spindle Lock Pin	1
25	-----	O-Ring	1
26	42-62-0125	Side Handle	1

FIG.	PART NO.	DESCRIPTION OF PART	NO. REQ.
27	05-88-1300	M4 x 28mm Pan Hd. ST T-20 Screw	4
28	-----	Spindle Lock Button	1
29	-----	Spindle Lock Spring	1
30	-----	Gearcase	1
31	05-55-0620	M5 Hex Nut	1
32	32-60-0165	Pinion	1
33	02-04-0620	Ball Bearing	1
34	44-66-0450	Bearing Retainer	1
35	05-88-1280	M4 x 10mm Pan Hd. T-20 Screw	2
36	45-88-0406	Washer	1
37	-----	Fan Baffle	1
38	-----	Fan Baffle Foot	1
39	-----	Rotor	1
43	02-04-0033	Ball Bearing	1
44	05-88-1200	M4 x 16mm Pan Hd. Plastite T-20 Screw	4
45	06-82-7236	4-20 x 5/8" Pan Hd. Plastite T-10 Screw	1
46	-----	Handle Cover - Right Side	1
49	-----	Handle Support - Left Side	1
50	-----	Paddle Trigger	1
51	-----	Lock-Off Lever	1
52	-----	Lock-Off Spring	1
53	-----	Lock-Off Pin	1
54	49-96-7205	Spanner Wrench	1
55	12-20-2685	Service Nameplate (Not Shown)	1
56	42-55-2684	Carrying Case	1
60	14-46-6105	Flange with Ramps Assembly	1
61	14-73-0428	Spindle Hub Assembly	1
62	14-30-1166	Gearcase Assembly	1
63	14-20-2690	Electronics Kit	1
64	31-44-0895	Housing Kit	1
65	42-14-0040	Baffle Assembly	1
66	44-86-0195	Bearing Retaining Plate Assembly	1
67	16-07-2690	Rotor Assembly	1
68	14-46-0630	Spindle Lock Kit	1
69	14-78-0575	Paddle Trigger Assembly	1
70	31-15-0275	Dust Cover	1

MILWAUKEE ELECTRIC TOOL CORPORATION
13135 W. LISBON RD., BROOKFIELD, WI 53005
Drwg. 5