



SERVICE PARTS LIST

BULLETIN NO.
54-38-1562

SPECIFY CATALOG NO. AND SERIAL NO. WHEN ORDERING PARTS		REVISED BULLETIN	DATE
7"/9" GRINDER with LOCK-ON		54-38-1561	Oct. 2012
CATALOG NO.	6088-30	WIRING INSTRUCTION	
SERIAL NUMBER	B43C	58-01-1376	

EXAMPLE:
00 0 Component Parts (Small #)
Are Included When Ordering
The Assembly (Large #).

FIG.	PART NO.	DESCRIPTION OF PART	NO REQ.
32	34-40-4300	O-Ring	(1)
33	34-80-2960	Retaining Ring	(1)
34	38-50-2500	Spindle Shaft	(1)
35	31-55-0290	Dust Shield	(1)
36	40-50-1550	Compression Spring	(1)
37	42-14-0425	Baffle	(1)
38	42-30-0150	Lock Body	(1)
39	42-42-0290	Button	(1)
41	43-34-0825	5/8 Back Flange	(1)
42	49-12-0010	7" Guard Assembly (Type 27)	(1)
42a	49-12-0020	9" Guard Assembly (Type 27)	(1)
43	43-62-1266	Side Handle	(1)
45	44-60-1650	Lock Pin	(1)
46	44-86-0040	Bearing Retainer	(1)

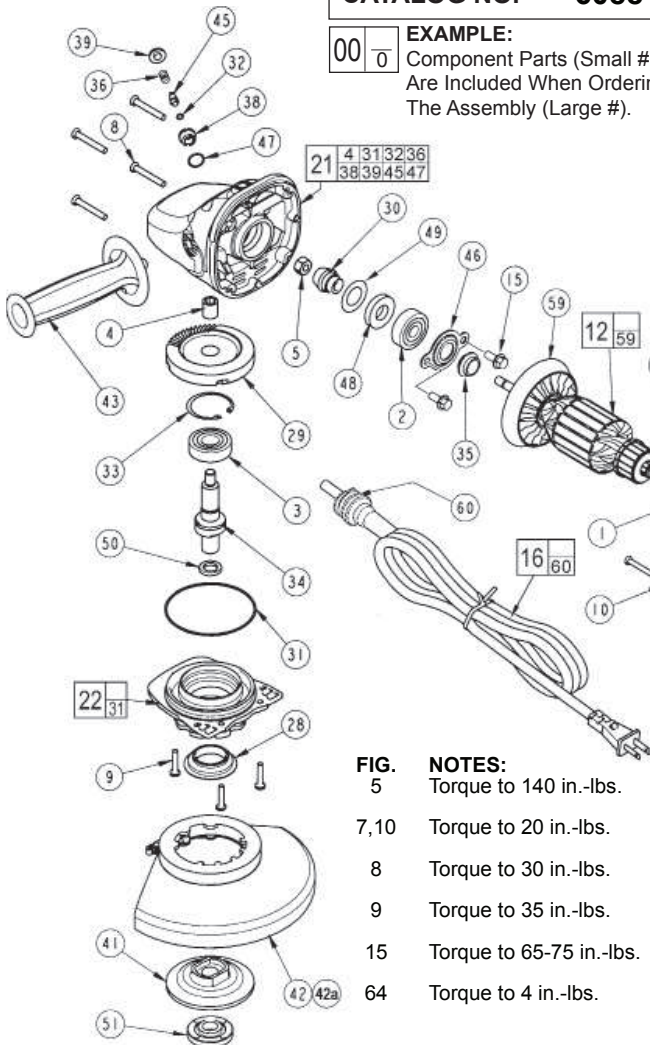

- FIG. NOTES:**
- 5 Torque to 140 in.-lbs.
 - 7,10 Torque to 20 in.-lbs.
 - 8 Torque to 30 in.-lbs.
 - 9 Torque to 35 in.-lbs.
 - 15 Torque to 65-75 in.-lbs.
 - 64 Torque to 4 in.-lbs.

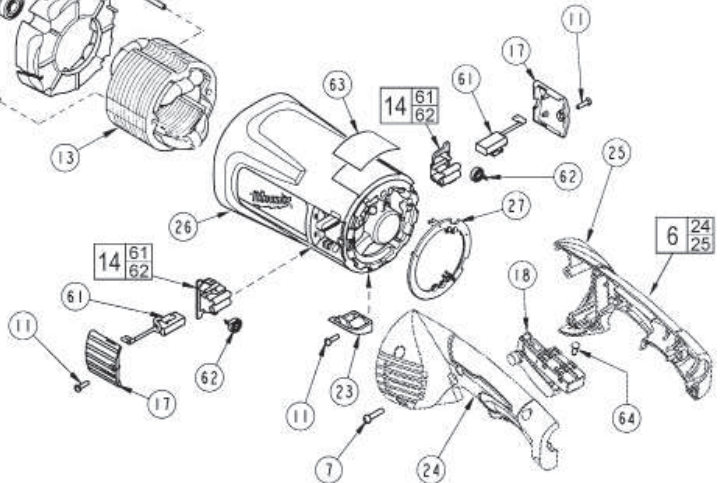

FIG.	PART NO.	DESCRIPTION OF PART	NO REQ.
1	02-04-1675	Ball Bearing	(1)
2	02-04-1680	Ball Bearing	(1)
3	02-04-1745	Ball Bearing	(1)
4	02-50-2429	Needle Bearing	(1)
5	06-55-2455	Hex Nut	(1)
6	14-34-0561	Handle Kit	(1)
7	06-82-0055	8-16 Torx Plastite Screw T-20	(5)
8	06-82-0060	10-14 Torx Plastite Screw T-25	(4)
9	06-82-0065	10-32 x 1 Pan Hd. Taptite T-25 Screw	(3)
10	06-82-0070	8-16 Torx Plastite Screw T-15	(2)
11	06-82-7240	6-19 x 1/2 Slt. Pan Hd. Plast. T-15	(3)
12	16-70-7132	Armature Assembly	(1)
13	18-70-7130	Field	(1)
14	22-20-0120	Brush Holder Assembly w/ Pop-Off	(2)
15	06-75-0510	1/4-20 x .62 Hex Flange Screw	(2)
16	22-64-3601	Cord Set (Incl. Cord Protector & Terminals)	(1)
17	23-44-0255	Brush Cover	(2)
18	23-66-2721	Switch	(1)
19	23-86-0160	Dust Seal	(1)
21	28-14-1131	Gearcase Assembly	(1)
22	28-53-0151	Spindle Hub Assembly	(1)
23	31-15-0166	Cover	(1)
24	-----	Left Hand Handle Halve	(1)
25	-----	Right Hand Handle Halve	(1)
26	31-50-1785	Motor Housing	(1)
27	31-53-0161	Plug	(1)
28	31-55-0150	Bearing Shield	(1)
29	32-05-1505	Gear	(1)
30	32-60-1505	Pinion Gear	(1)
31	34-40-0505	O-Ring	(1)

FIG.	PART NO.	DESCRIPTION OF PART	NO REQ.
47	34-40-4555	O-Ring	(1)
48	45-06-0710	Seal	(1)
49	45-88-7880	Shim Washer	(1)
50	45-88-8466	5/8-11 Spindle Washer	(1)
51	49-05-0110	Flange Nut	(1)
59	22-84-0540	Fan Assembly	(1)
60	-----	Cord Protector	(1)
61	22-18-0126	Carbon Brush Assembly w/ Pop-Off	(2)
62	-----	Brush Spring	(2)
63	12-99-5008	Nameplate Blank	(1)
64	05-78-0305	Switch Screw	(4)
	49-96-7205	Spanner Wrench	(1)
	10-98-6085	Warning Label, French & Spanish	(1)

FIG. LUBRICATION:
21 1.25 oz. (35 grams) of Type "Y" grease, No. 49-08-5270 in main gear cavity of gearcase.

29,30 "Y" grease must be applied to all gear teeth.

31,32 Lightly coat o-rings with "Y" grease prior to installation.

FIG. NOTES:
4,21 Press needle bearing flush ±.02 to gearcase boss face.

33 Bevel side of retaining ring away from bearing face.

MILWAUKEE ELECTRIC TOOL CORPORATION
13135 W. LISBON RD., BROOKFIELD, WI 53005
Drwg. 1