



SERVICE PARTS LIST

BULLETIN NO.
54-42-6178

SPECIFY CATALOG NO. AND SERIAL NO. WHEN ORDERING PARTS		REVISED BULLETIN 54-42-6177	DATE June 2011
DRYWALL SCREWDRIVER			
CATALOG NO. 6742-20	STARTING SERIAL NO. 146D	WIRING INSTRUCTION 58-01-1801	

EXAMPLE:

00	0
----	---

 Component Parts (Small #) Are Included
 When Ordering The Assembly (Large #).

★ = Part number change from previous service parts list.

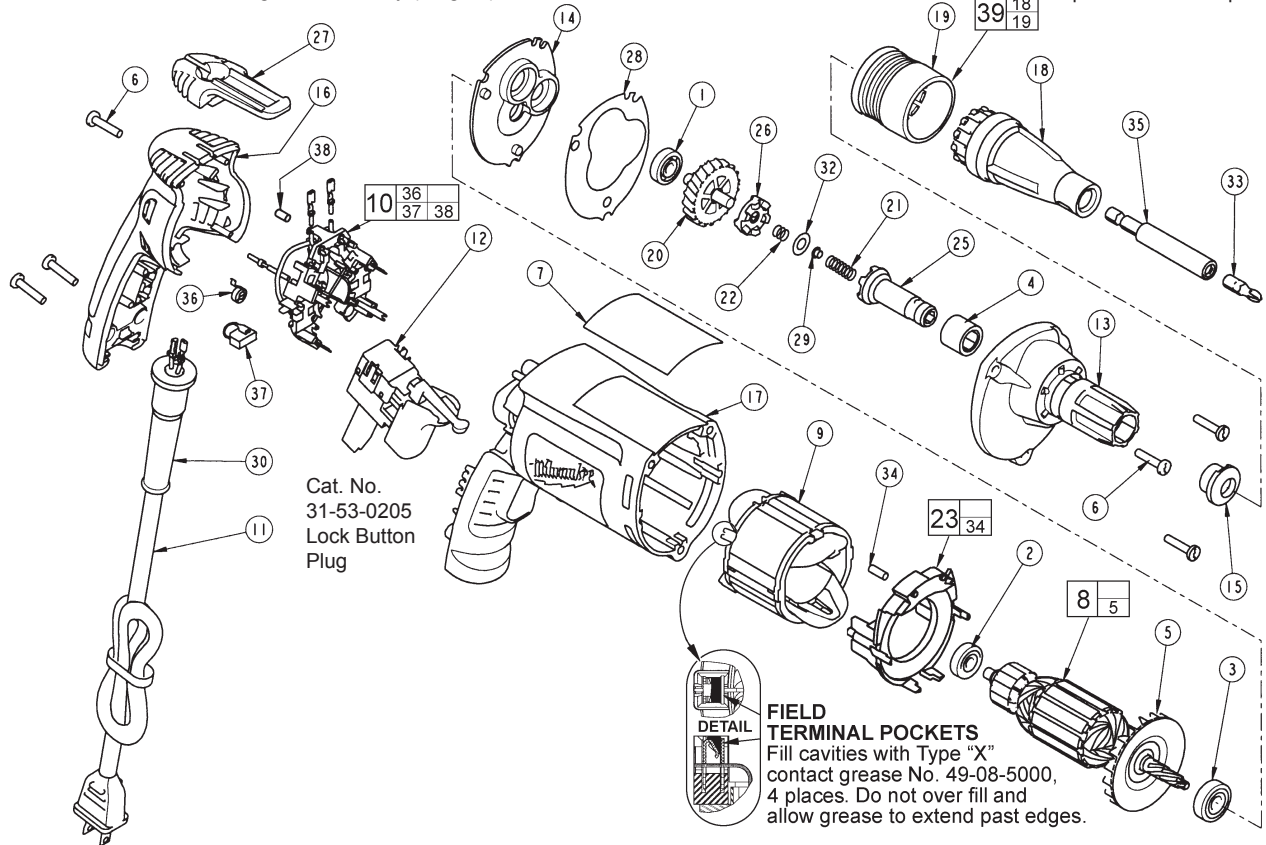

FIG.	PART NO.	DESCRIPTION OF PART	NO. REQ.
1	02-04-0640	Ball Bearing	(1)
2	02-04-0645	Ball Bearing	(1)
3	02-04-0852	Ball Bearing	(1)
4	02-50-3245	Needle Bearing	(1)
5	22-84-0840	Fan	(1)
6	06-82-7275	7-18 x 3/4" Slotted Plastite Torx T-20	(6)
7	12-99-2665	Service Nameplate	(1)
8	16-10-2201	Armature	(1)
9	18-07-2200	Field	(1)
10	22-18-1210	Brush Card Assembly	(1)
11	22-64-6510	Cord Assembly	(1)
★12	23-66-2605	Switch	(1)
13	28-14-2375	Gearcase	(1)
14	28-28-2315	Diaphragm	(1)
15	30-37-0046	Drywall Nose Guide	(1)
16	31-15-2010	Handle Halve	(1)
★17	31-50-4010	Motor Housing	(1)
18	31-51-0095	Drywall Locator	(1)
19	31-58-0515	Snap Sleeve	(1)
20	32-10-0521	Clutch Gear Assembly	(1)
21	40-50-0095	Separator Spring	(1)
22	40-50-8515	Bias Spring	(1)
23	42-14-0460	Baffle Assembly	(1)
25	42-66-0715	Clutch Chuck Assembly	(1)
26	42-70-0310	Drive Clutch	(1)
27	42-70-5280	Belt Clip	(1)
28	43-44-0985	Gasket	(1)
29	44-60-0505	Thrust Pin	(1)
30	44-76-0210	Cord Protector	(1)
32	45-88-0555	Clutch Thrust Washer	(1)
33	48-32-1040	#2 Phillips Insert Bit	(1)
34	45-30-0030	Slug	(2)

FIG.	PART NO.	DESCRIPTION OF PART	NO. REQ.
35	48-32-3065	Magnetic Bit Holder	(1)
36	23-52-1610	Brush Spring	(2)
37	22-18-1310	Brush Assembly	(2)
38	45-30-0035	Slug	(1)
39	49-26-1036	Drywall Locator Assembly	(1)

LUBRICATION (Type "Y" Grease, No. 49-08-5270)

- Fill the 3 enlarged clutch pockets of the clutch gear assembly (20) with .5 gm. (.02 oz.) grease.
- Apply the same amount of grease in the bias spring (22).
- Apply in total .5 gm. (.02 oz.) grease to the clutch thrust washer (32), thrust pin (29) and separator spring (21).
- Place 7.7 gm. (.27 oz.) of grease at the armature pin location in the gearcase (13) and fill to slightly above the next higher gearcase level.
- Apply a light film of grease to the lead chamfer of the clutch chuck (25) prior to assembly.

Before assembly, lightly coat all press fit areas with lightweight spindle oil.

FIG. NOTES:

- 4 Needle bearing to have it's seal toward the front of the tool. Needle bearing to be pressed .133/.143 under flush.

MILWAUKEE ELECTRIC TOOL CORPORATION
 13135 W. LISBON RD., BROOKFIELD, WI 53005
 Drwg. 2