



SERVICE PARTS LIST

BULLETIN NO.
54-38-0520

SPECIFY CATALOG NO. AND SERIAL NO. WHEN ORDERING PARTS		REVISED BULLETIN	DATE
RANDOM ORBIT SANDER			Aug. 2015
CATALOG NO. 6034-21	STARTING SERIAL NO. G66A	WIRING INSTRUCTION See Reverse Side	

EXAMPLE:
Component Parts (Small #)
Are Included When Ordering
The Assembly (Large #).

NOTE: This assembly contains the sensormatic label. It is not a serviceable part.

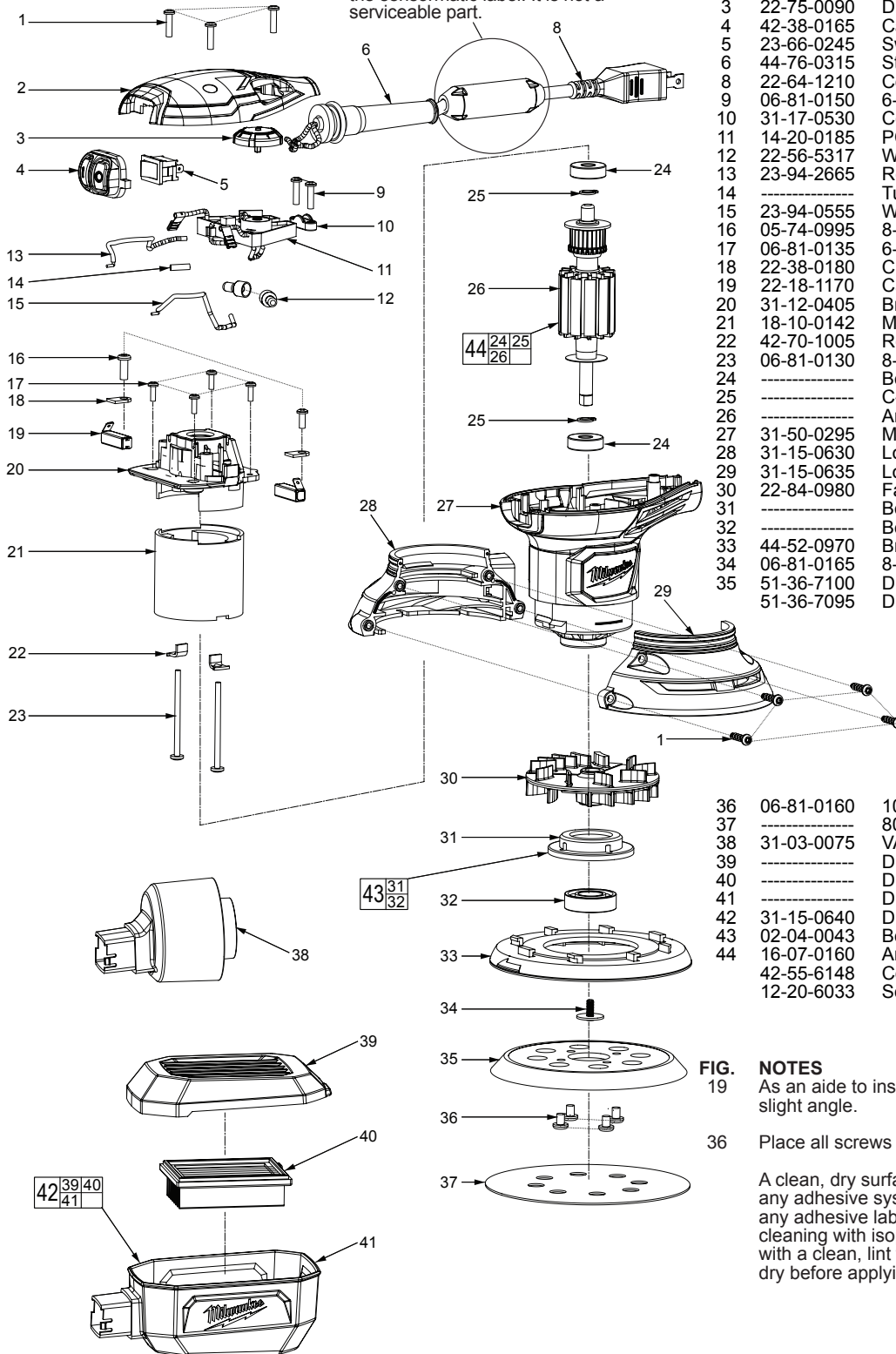

FIG.	PART NO.	DESCRIPTION OF PART	NO. REQ.
1	06-81-0145	8-18 x 5/8" Pan Hd. T-15 Screw	7
2	31-12-0045	Top Cap	1
3	22-75-0090	Dial	1
4	42-38-0165	Cap	1
5	23-66-0245	Switch	1
6	44-76-0315	Strain Relief	1
8	22-64-1210	Cord	1
9	06-81-0150	6-19 x 5/8" Pan Hd. T-15 Screw	2
10	31-17-0530	Cord Clamp	1
11	14-20-0185	PCBA Assembly	1
12	22-56-5317	Wire Connector (see wiring)	2
13	23-94-2665	Receptacle w/ Wire	1
14	-----	Tube	1
15	23-94-0555	Wire	1
16	05-74-0995	8-16 x 1/2" Pan Hd. T-20 Screw	2
17	06-81-0135	6-19 x 7/16" Pan Hd. T-15 Screw	4
18	22-38-0180	Clamp Brush	2
19	22-18-1170	Carbon Brush Assembly	2
20	31-12-0405	Bracket	1
21	18-10-0142	Motor Field	1
22	42-70-1005	Retaining Clip	2
23	06-81-0130	8-10 x 2-1/8" Pan Hd. T-20 Screw	2
24	-----	Bearing	2
25	-----	C-Ring	2
26	-----	Armature	1
27	31-50-0295	Motor Housing	1
28	31-15-0630	Lower Housing Support	1
29	31-15-0635	Lower Housing Cover	1
30	22-84-0980	Fan	1
31	-----	Bearing Cap	1
32	-----	Bearing	1
33	44-52-0970	Brake	1
34	06-81-0165	8-32 x 3/8" Pan Washer Hd. T-20 Screw	1
35	51-36-7100	Disc Assembly (Hook and Loop)	1
	51-36-7095	Disc Assembly (PSA)	1
36	06-81-0160	10-32 x 1/4" Pan Hd. T-25 Screw	4
37	-----	80 Grit Sand Paper	2
38	31-03-0075	VAC Adapter	1
39	-----	Dust Box Cover w/ Rubber Lining	1
40	-----	Dust Box Filter	1
41	-----	Dust Box Body	1
42	31-15-0640	Dust Box Assembly	1
43	02-04-0043	Bearing Assembly	1
44	16-07-0160	Armature Assembly	1
	42-55-6148	Contractor Bag (not shown)	1
	12-20-6033	Service Nameplate (not shown)	1

FIG. NOTES
19 As an aide to installation, brushes may have to be put in at a slight angle.

36 Place all screws in before tightening. Do not overtighten.

A clean, dry surface is essential for proper performance for any adhesive system. The area intended for application of any adhesive label or nameplate must be prepared by cleaning with isopropyl alcohol. The solvent is to be applied with a clean, lint free applicator and the surface allowed to dry before applying the label or nameplate.